

THE SIMPSONS

EPISODE #	2F03
EPISODE TITLE	"TREEHOUSE OF HORROR V"
<h1>ACT I</h1>	
ROUGH DRAFT	5/6/94
REVISED	5/19/94
FINAL	

FILM ROMAN

THE SIMPSONS

TITLE "TREEHOUSE OF HORROR V"

SHOW 2F03

ACT I

PAGE 1

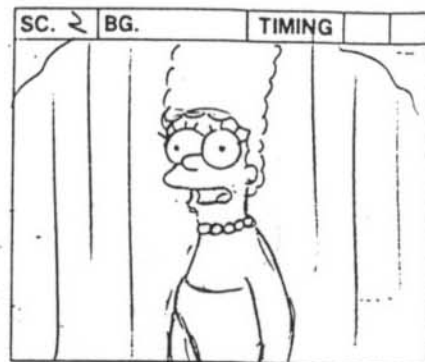
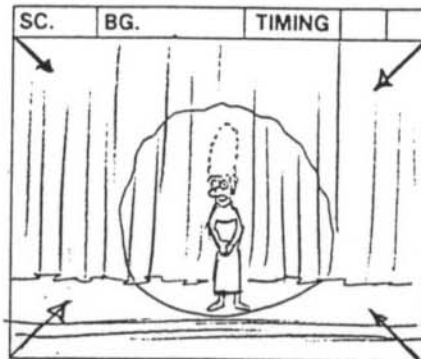
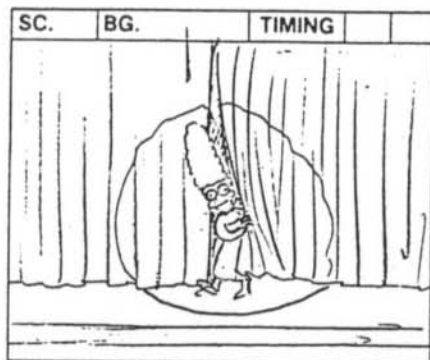
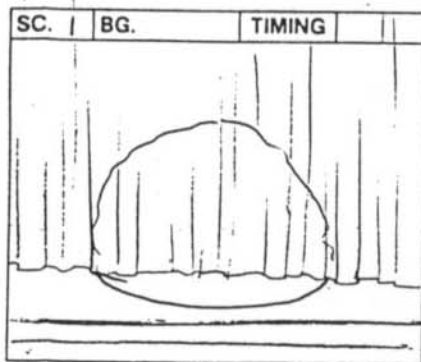

ACTION

SPOTLIGHT ON CURTAIN

MARGE OUT FROM BEHIND CURTAIN

SLOW TRUCK IN

FADE IN:

MARGE comes out through a curtain and addresses the audience.

TRANS.

DIAL

MARGE

Hello, once again.

As usual, I must

warn you all that this year's Halloween show is very, very scary

3

TRANS.

NOTES

FILM ROMAN

THE SIMPSONS

TITLE _____ SHOW 2F03 ACT I PAGE 2

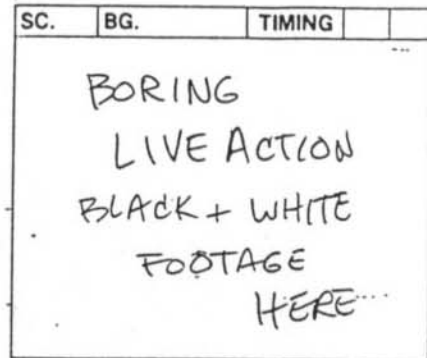
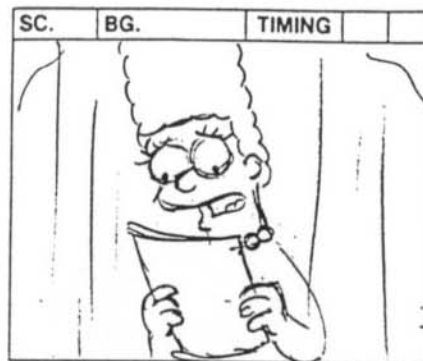
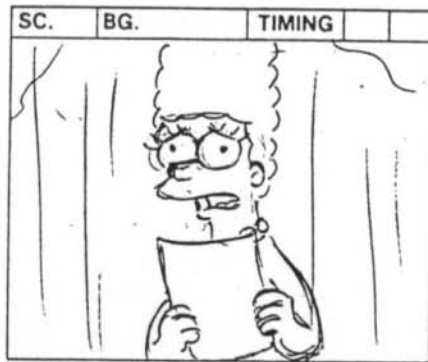
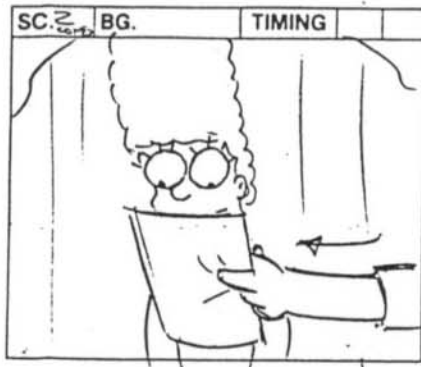

ACTION

HAND IN W/ PAPER

An arm comes into frame and hands her a piece of paper.

We see boring, live action, black and white footage of covered wagons inching across the prairie (including steers, campfires, and chuck wagon shots).

TRANS.

DIAL

MARGE (CONT'D)

(READING) Oh my.

It seems the show is
so scary, that Congress won't even let
us show it.

Instead they've suggested
the 1947 classic Glenn Ford movie, "200
Miles To Oregon."

TRANS.

NOTES

FILM ROMAN

THE SIMPSONS

TITLE _____

SHOW 2F03

ACT I

PAGE 3

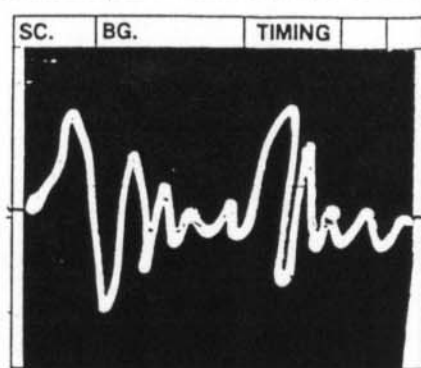
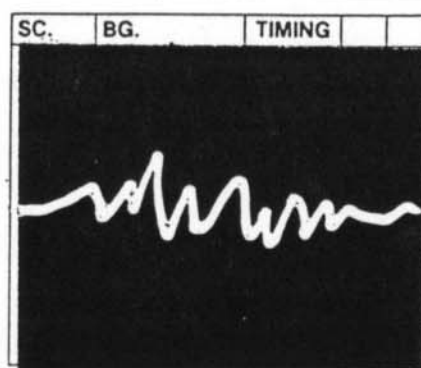
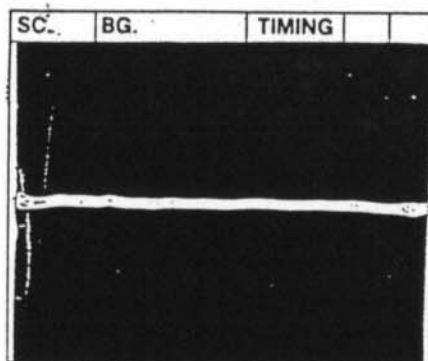
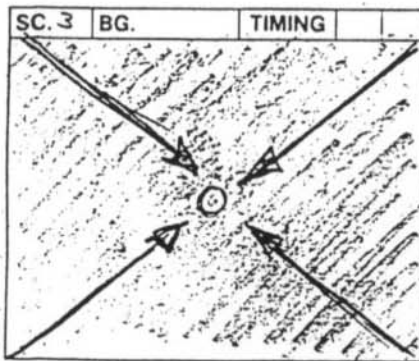

ACTION

TV SCREEN GOES
BLACK EXCEPT FOR DOT
picture raster goes all funny, then collapses into a single dot. The dot stretches and becomes a voice-activated oscilloscope.

SIGN WAVE APPEARS
Suddenly the

TRANS.

DIAL

BART (V.O.)
(SOMBER VOICE) There's nothing wrong with your television set. Do not attempt to adjust your picture. We are controlling the transmission...

HOMER (V.O.)
What's that boy? We're in control? Hey, look. I can see my voice.
(LAUGHS)

TRANS.

NOTES

FILM ROMAN

THE SIMPSONS

TITLE _____

SHOW _____

2F03 ACT _____

I

PAGE 4

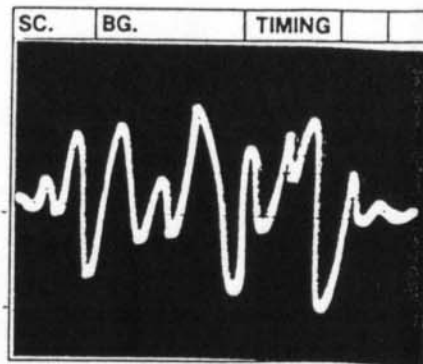
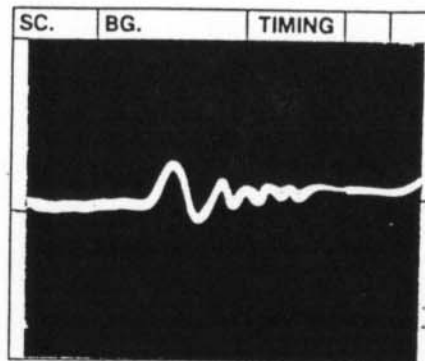
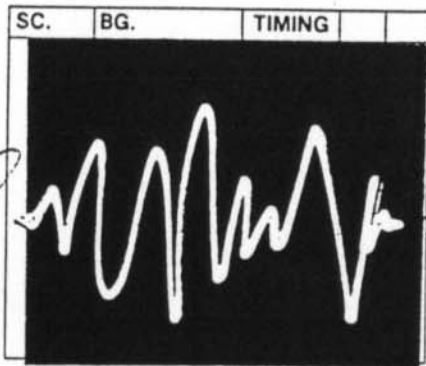
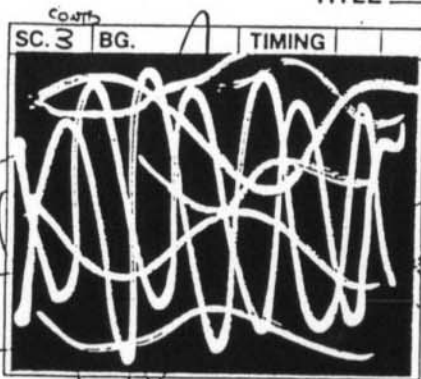

ACTION

(A) He makes a series of experimental SILLY NOISES, which makes the oscilloscope go nuts.

TRANS.

(B) Homer laughs, makes more SILLY NOISES.

DIAL

(A) HOMER
(SINGS) This is my voice on T.V.

BART (V.O.)
(ADMONISHING) Dad! You're ruining the mood.

HOMER (V.O.)
Sorry...

BART (V.O.)
(SOMBER VOICE) For the next half hour, we will control what you see and hear.

TRANS.

(B) HOMER
(LAUGHING) Look, it even knows when I laugh.

NOTES

FILM ROMAN

THE SIMPSONS

TITLE _____

SHOW 2FD3

ACT I

PAGE 5

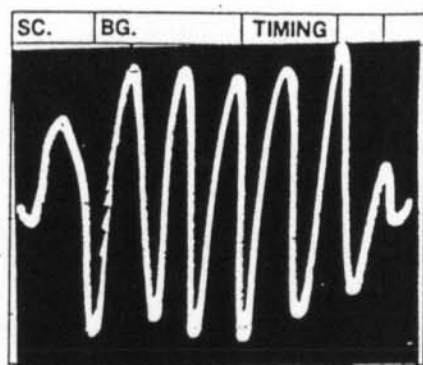
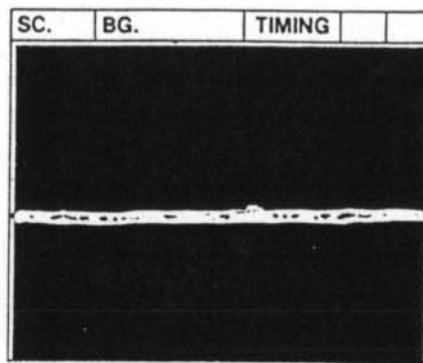
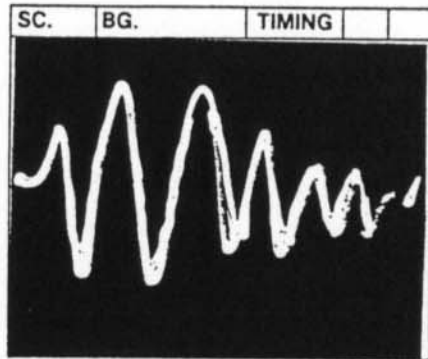
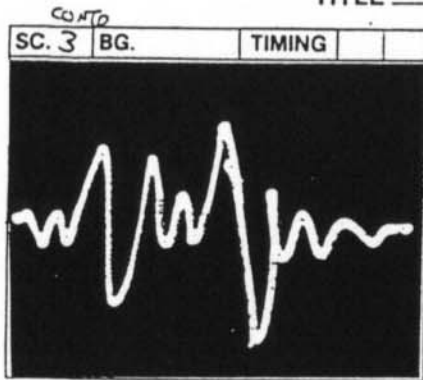

ACTION

TRANS.

DIAL

TRANS.

NOTES

<p>ACT SIGN WAVE POSES; ON "SPECIAL"</p>			
<p><u>BART</u></p>	<p><u>BART</u> The Simpsons Halloween Special.</p>		<p>HOMER (V.O.) (HIGH VOICE) Wee, wee.</p>
<p>You are about to experience the terror and foul horror of...</p>			

FILM ROMAN

THE SIMPSONS

TITLE _____

SHOW 2F03

ACT I

PAGE 6

PAN
BG

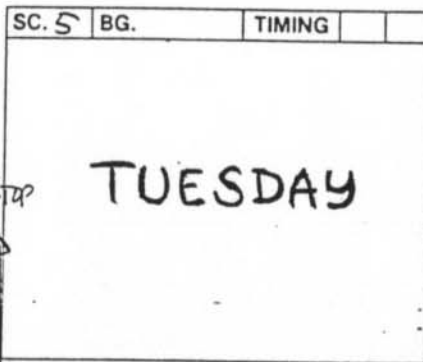
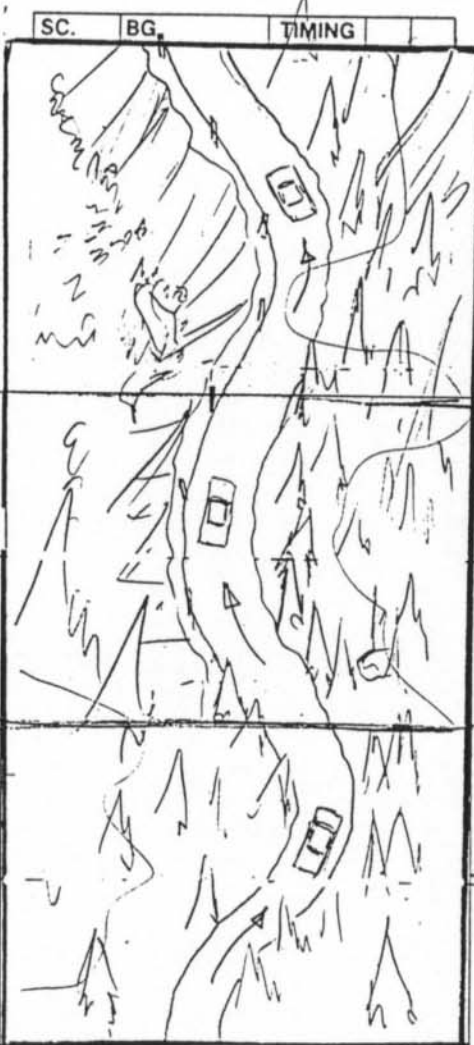
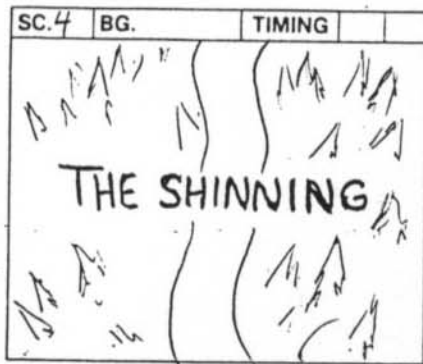

ACTION

START ON PANNING
DOWN SHOT OF FOREST

MOUNTAIN ROAD - DAY

FRIGHTENING WENDY CARLOSQUE MUSIC OVER THE
LOWING:

TRANS.

TITLE CARD: WHITE LETTERS ON
BLACK BACKGROUND READS "TUESDAY"

DIAL

BY AIRSWITH
CLOUDS OVER
SC.

GAN UP
TO CAR

As the car continues climbing toward an ominous-look
mansion (a la the Overlook Hotel.)

TRANS.

NOTES

A distant OVERHEAD SHOT of the Simpsons' car driving along
a twisty, cliff-side, two-lane highway, leading to large
mountains.

BACK TO SCENE PAN UP TO HOTEL

FILM ROMAN

THE SIMPSONS

TITLE _____

SHOW 2F03

ACT I

PAGE 7

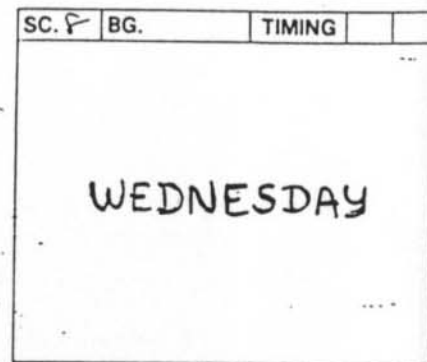
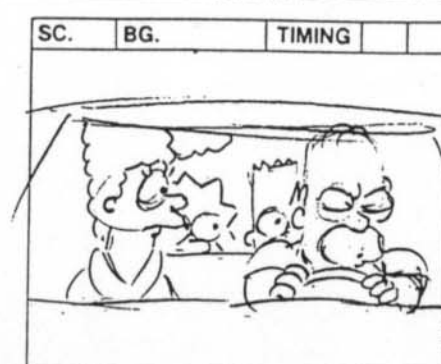
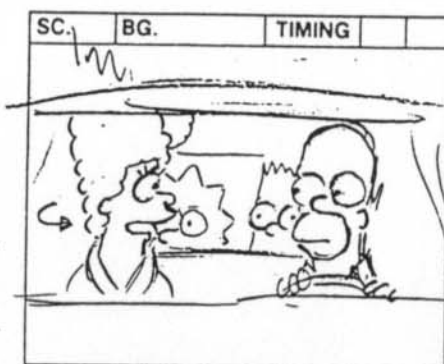
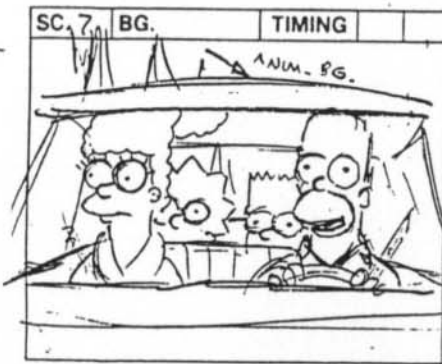

ACTION



TITLE CARD: "WEDNESDAY"

TRANS.

DIAL

HOMER

Well, it was a long trip, but we're almost there.

MARGE

Homer, did you remember to lock the front door of the house?

HOMER

(ANNOYED GRUNT)

TRANS.

NOTES

FILM ROMAN

THE SIMPSONS

TITLE _____

SHOW 2F03 ACT I PAGE 8

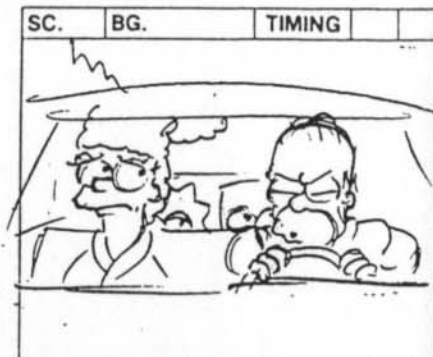
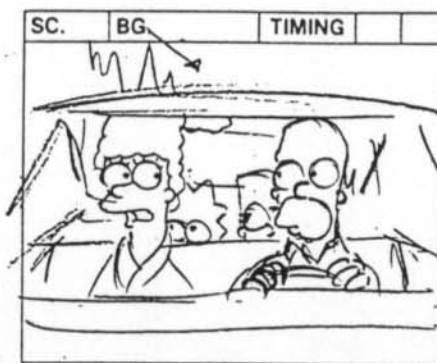
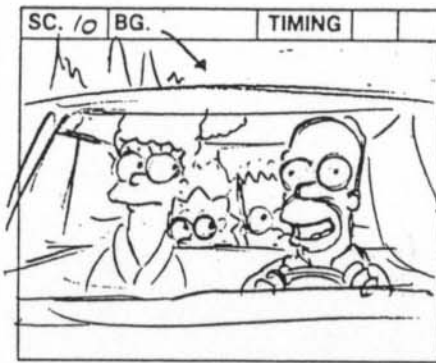
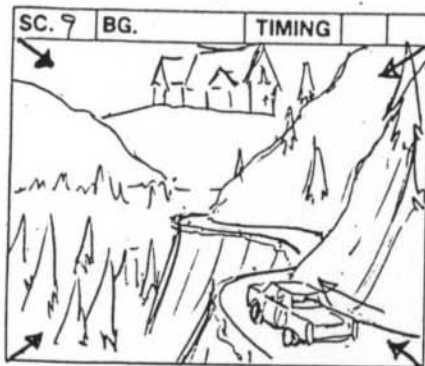

ACTION

The car approaches the mansion one more time.

TRANS.

DIAL

HOMER

Well, it's been two long trips, but we're finally almost there, again.

MARGE

When you locked the front door, did you remember to lock the back door?

(ANNOYED GRUNT)

TRANS.

NOTES

FILM ROMAN

THE SIMPSONS

TITLE _____ SHOW 2FD3 ACT I PAGE 9

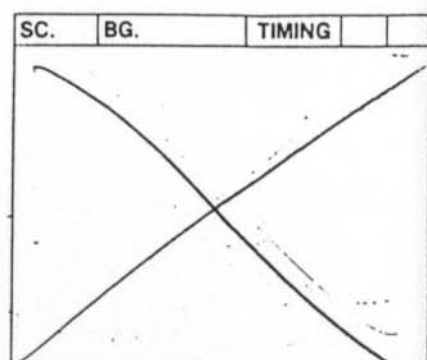
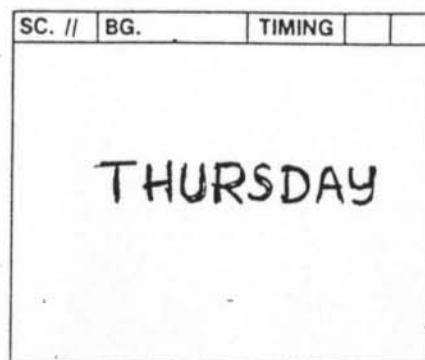
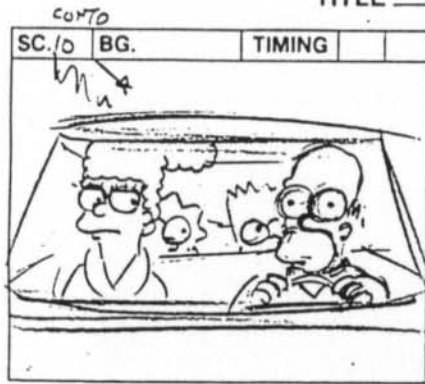

ACTION

TITLE CARD: "THURSDAY"

TRANS.

DIAL

(SECOND ANNOYED GRUNT)

TRANS.

NOTES

FILM ROMAN

THE SIMPSONS

TITLE _____

SHOW 2F03

ACT I

PAGE 10

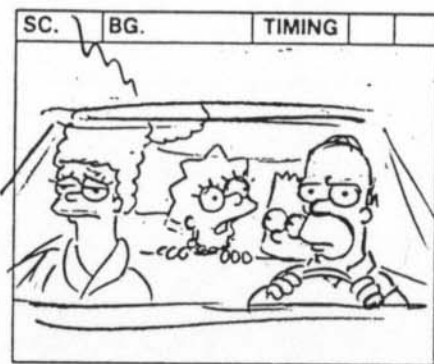
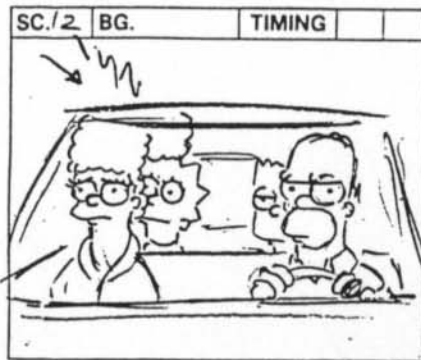

ACTION

The car approaches the mansion, yet again.

LISA
 LOOKS TO
 MARGE

TRANS.

There is a long beat as the car continues to drive.

DIAL

LISA
 (GASP) Oh no! We left Grampa back at
 the gas station.

LISA (CONT'D)
 What about Grampa?

TRANS.

NOTES

FILM ROMAN

THE SIMPSONS

TITLE _____

SHOW 2F03

ACT I

PAGE 11

SC. 13 BG. TIMING



ACTION

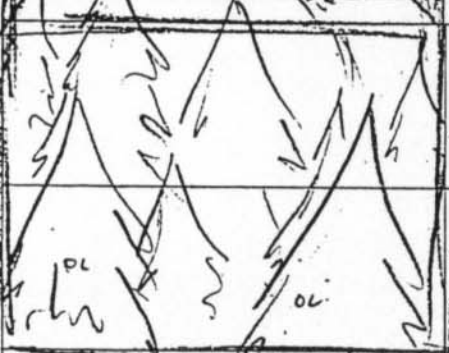

TRANS.

DIAL

PAN UP FROM TREES TO MANSION

EXT. BURNS' MOUNTAIN RETREAT - ESTABLISHING - LATER
The Simpsons' car pulls up to the sprawling estate.

NOTES

SC. 15 BG. TIMING



START TIGHT ON CAR
PULLING UP

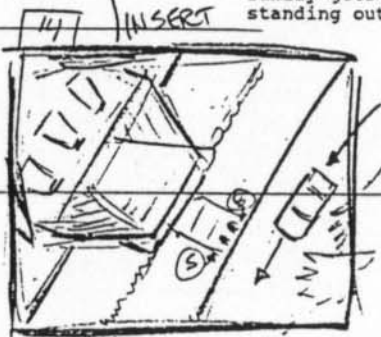

DOWN SHOT OF
DRIVEWAY
CAR PULLS UP

family gets out and waves to BURNS and SMITHERS who are standing out front.

SC. BG. TIMING



WIDEN OUT TO REVEAL
BURNS + SMITHERS

SIMPSONS
(VARIOUS GREETINGS) "Hello." "We're here." "Hi." etc.

SC. BG. TIMING



The

BURNS
(EYEING SIMPSONS) Oh goody, the Sea Monkeys I ordered have arrived.

FILM ROMAN

THE SIMPSONS

TITLE _____

SHOW 2F03

ACT I

PAGE 12

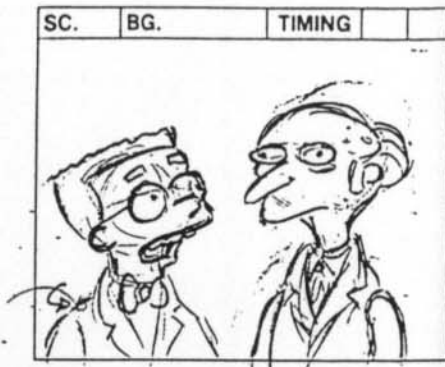
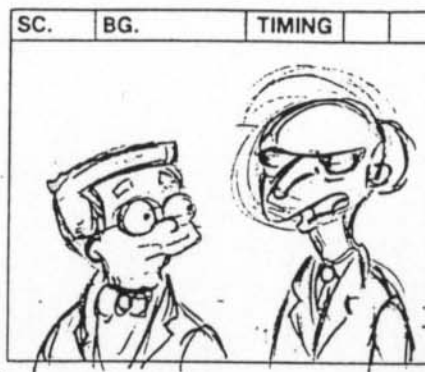
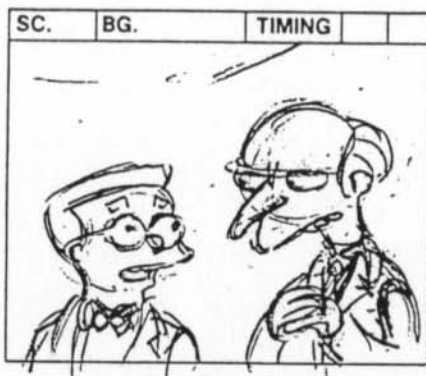

ACTION

TRANS.

DIAL

TRANS.

NOTES

(L.M.G.F.S) Look
at them cavort and caper.

SMITHERS

Sir, that's Homer Simpson, the new
caretaker, and his family.

BURNS

All right, but if they don't work out,
I'm going to flush them down the
toilet.

SMITHERS

Sir, they're not Sea Monkeys.

FILM ROMAN

THE SIMPSONS

SHOW 2F03 ACT I PAGE 13

TITLE _____

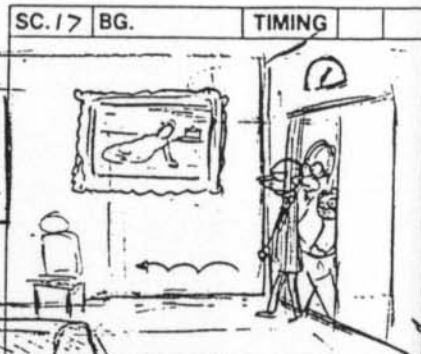
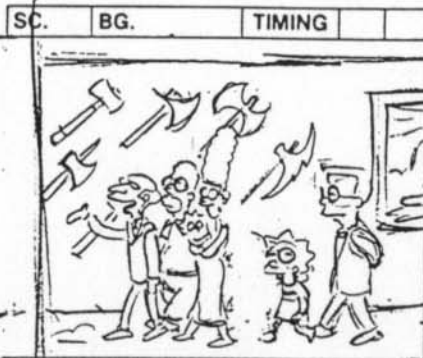
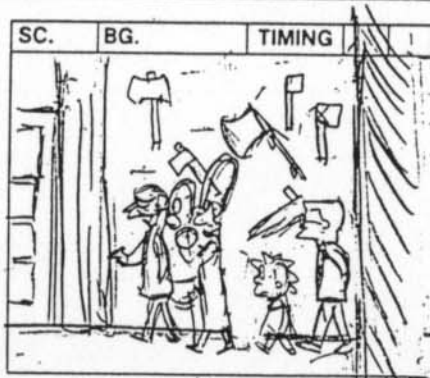

ACTION

SLIGHT TRUCK IN

NO BALT
IN SC.

PAN
PAST
AXE COLL-

PAN W/ GROUP
LOOKING AROUND

START
ELEVATOR
DOORS
OPEN

TRANS.

INT. RETREAT - LIVING ROOM

Large elevator doors open. Burns, Smithers, Homer, Marge, and Lisa walk into the large cavernous, ECHOING living room, past a huge collection of axes.

DIAL

BURNS
(HONESTLY) I know.

BURNS

This house has quite a long and colorful history. It was built on an ancient Indian burial ground, and was the setting of satanic rituals, witch burnings, and five John Denver Christmas Specials.

TRANS.

NOTES

FILM ROMAN

THE SIMPSONS

TITLE _____

SHOW 2F03

ACT I

PAGE 14

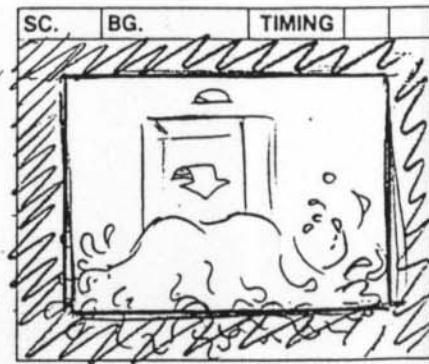
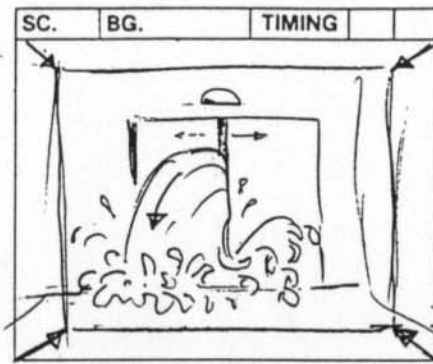
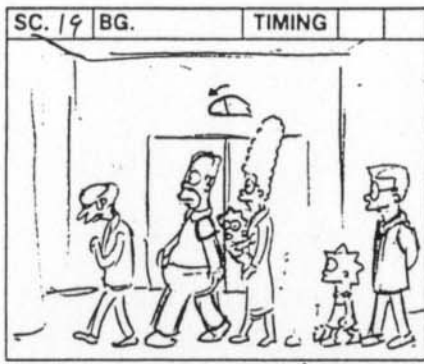
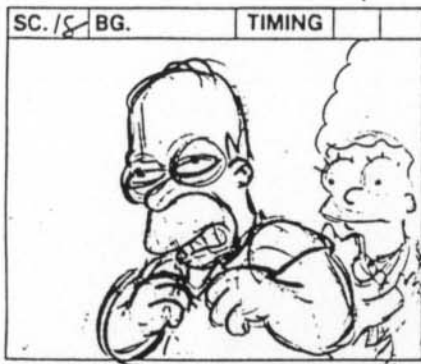

ACTION

HOMER SHUDDERS

GROUP CONTINUES
WALK O.S.

ELEVATOR DOORS
OPEN, BLOOD
GUSHES OUT

BLOOD GUSHES
DOWN HALL,
TOWARDS CAM.

TRANS.

Down the hall an elevator opens and blood cascades out in ominous slow motion.

DIAL

HOMER
(SHUDDERS) John Denver.

Stop & look
down a hall -
show their
P.O.V. of
elevator.

TRANS.

NOTES

FILM ROMAN

THE SIMPSONS

TITLE _____ SHOW ZF03 ACT I PAGE 15

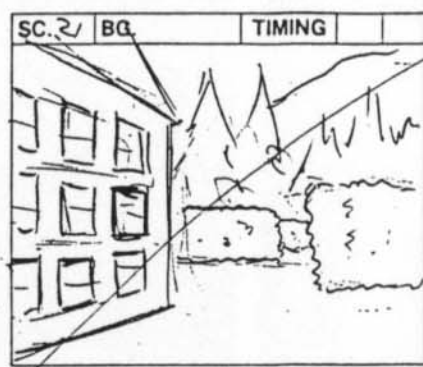
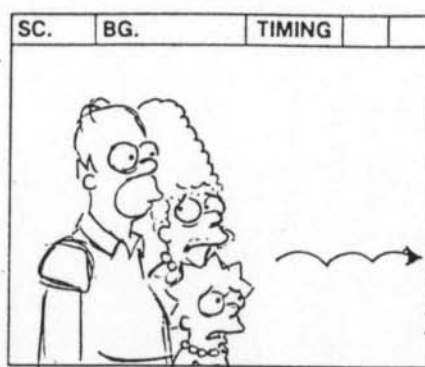
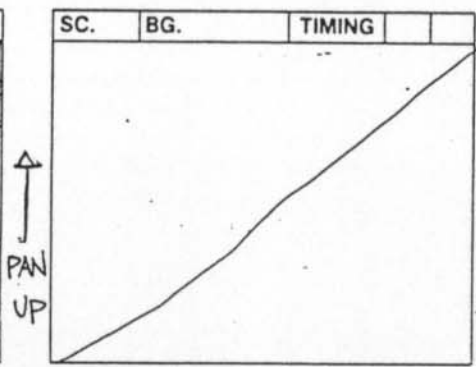
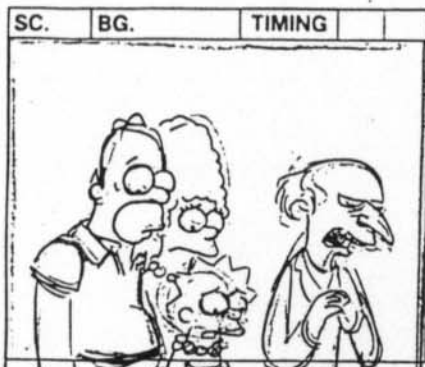

ACTION

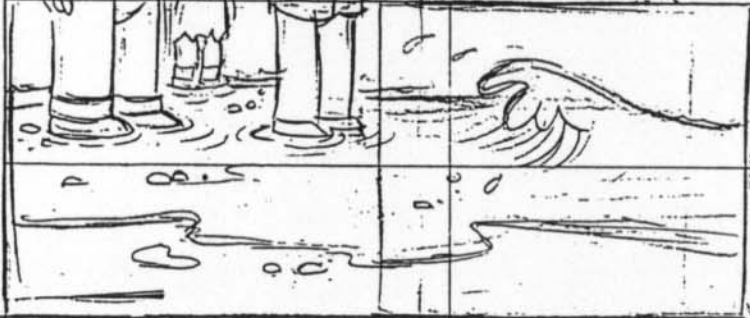

TRANS.

DIAL

BURNS
 Hmm, that's odd. Usually the blood gets off at the second floor.

← ADJUST OVER

MARGE
 (CONCERNED MURMUR)

TRANS.

They don't move until after line.

NOTES

FILM ROMAN

THE SIMPSONS

TITLE _____

SHOW 2F03

ACT I

PAGE 16

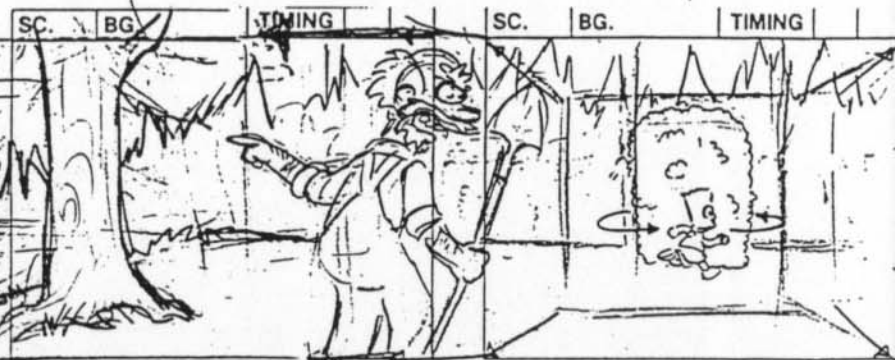
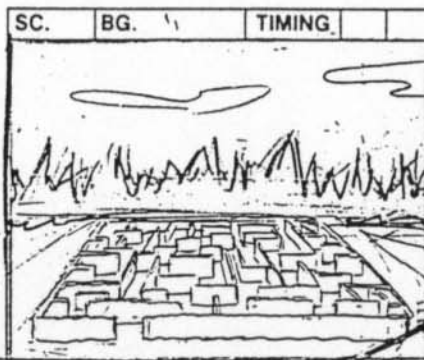
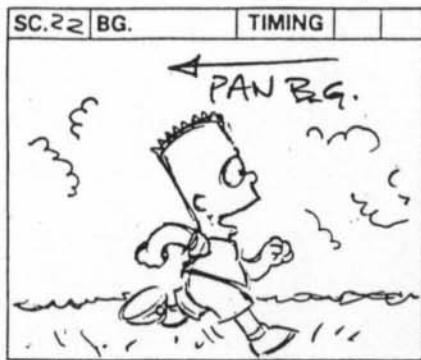

ACTION

Bart is running past a wall of green hedge.

← PAN TO MAZE

PAN TO WILLY ←

TRUCK OUT TO REVEAL BUSH

TRANS.

Bart happens not as hectic lower horizon & lose trees (?)

We PULL BACK to see Bart is running repeatedly around the same bush.

He points to a gigantic super complicated hedgemaze.

DIAL

BART

Everybody says it's tough to get out of a hedgemaze, but this is a piece of cake!

VOICE (O.S.)

Help! It's me, John Denver. I've been stuck in here since '77. I've got a whole lotta new songs. (SINGING TO THE TUNE OF "YOU FILL UP MY SENSES.") "I'm stuck in a hedgemaze."

GROUNDSKEEPER WILLIE

That's not a hedgemaze, ya cookie-chompin' wedgie bait. The real hedgemaze is over there!

TRANS.

Bart stops & looks around, then continues running

NOTES

FILM ROMAN

THE SIMPSONS

TITLE _____

SHOW 2F03

ACT I

PAGE 17

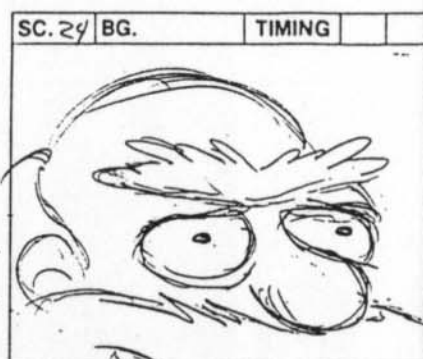
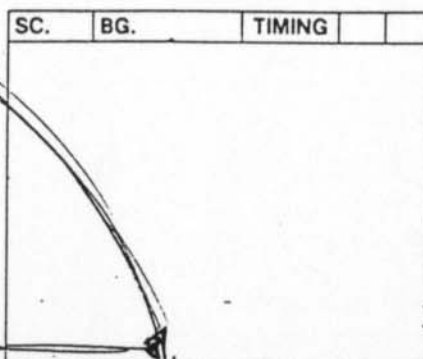
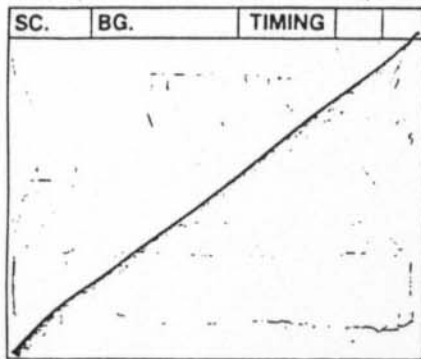

ACTION

TRANS.

DIAL

TRANS.

NOTES

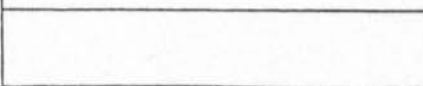
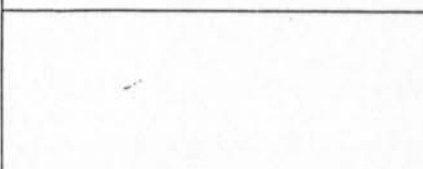
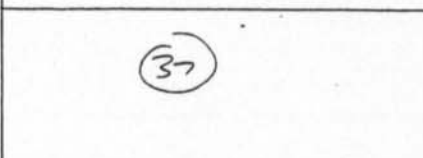
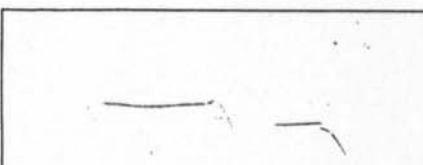

check
Bart
model

C.U. WILLIE'S BRAIN
fights on
brain.

[Blank space]

GROUNDKEEPER WILLIE'S BRAIN (V.O.)
Poor li'l wee one. His father's gonna
go loose in the bean and make haggis of
all of 'em.

GROUNDKEEPER WILLIE *STOP*
A Shut up, ya bang-wearin' tree hugger!
B (TO BART) So your da' is gonna be the
caretaker this winter.

BART
Ya-huh.

FILM ROMAN

THE SIMPSONS

TITLE _____

SHOW 2F03

ACT I

PAGE 18

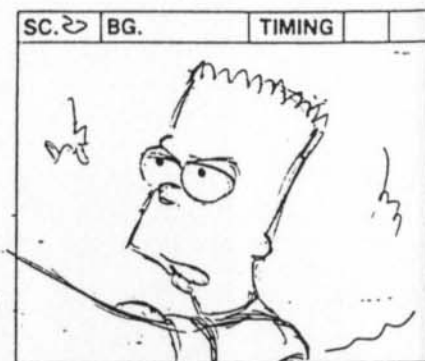
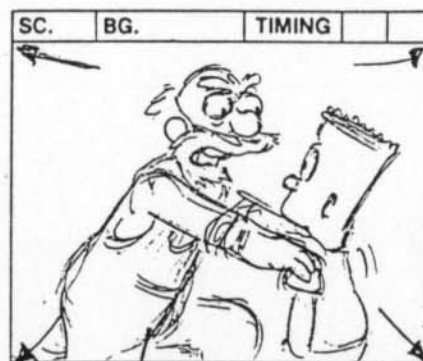
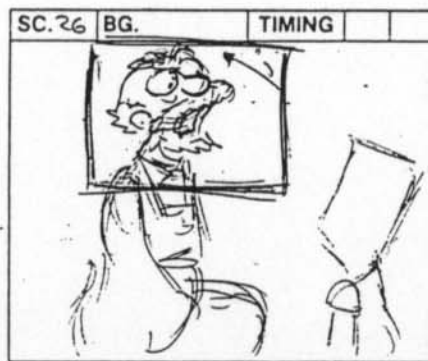
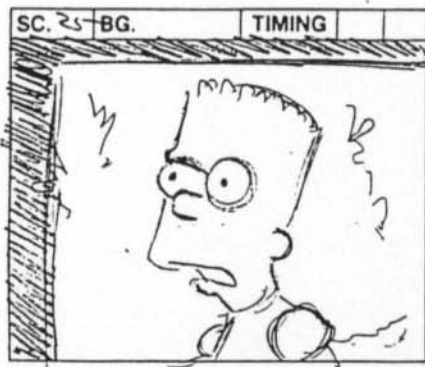

ACTION

START TIGHT ON WILLIE

WIDEN

TRANS.

DIAL

BART
What's haggis?

GROUNDSKEEPER WILLIE
(GASP) Boy, you read my thoughts!

You've got the "shinning."

BART
You mean "shining."

TRANS.

NOTES

FILM ROMAN

THE SIMPSONS

TITLE _____

SHOW 2F03

ACT I

PAGE 19

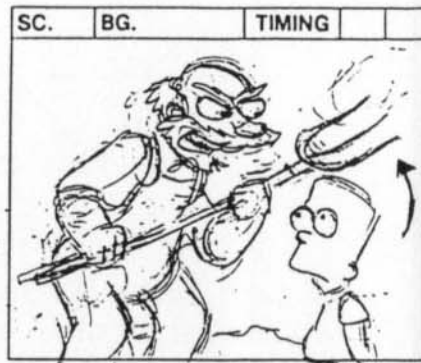
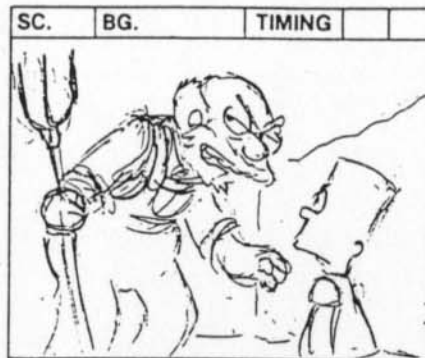
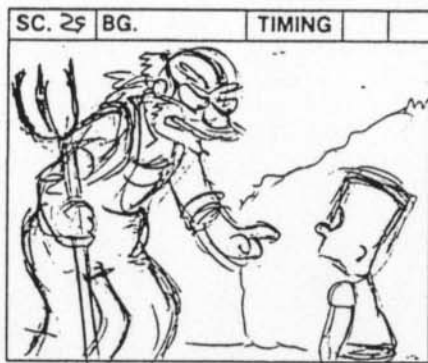

ACTION



TRANS.

DIAL

GROUNDKEEPER WILLIE
Shhh! You wanna' get sued?

Now look,
boy. If your Da' goes ga-ga, you just
use that

(EYES DARTING) "shin" of yours
to call me

and I'll come a-runnin'.

TRANS.

NOTES

FILM ROMAN

THE SIMPSONS

SHOW 2F03 ACT I PAGE 20

TITLE _____

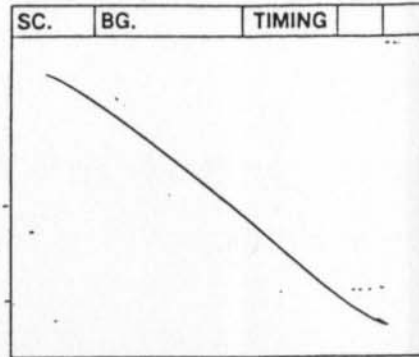
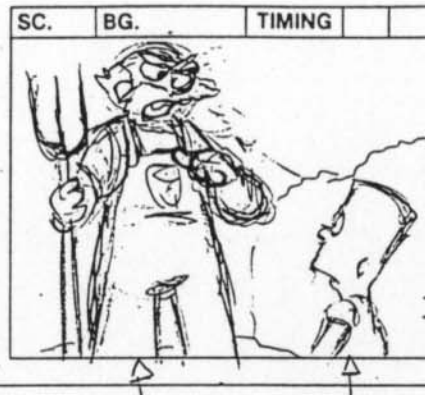
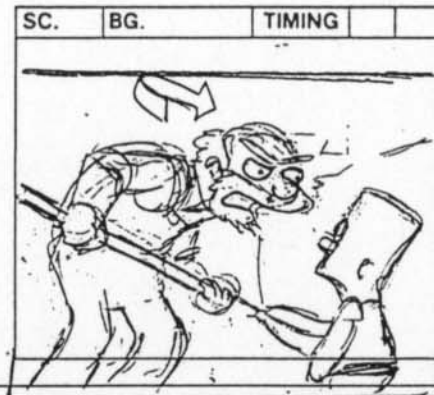
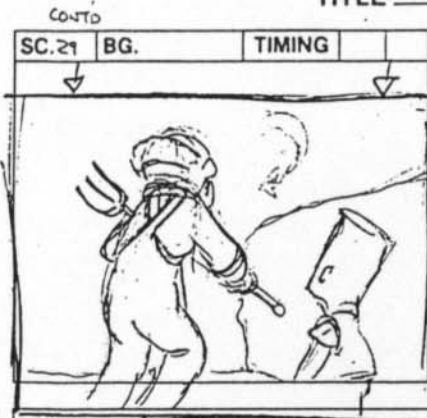

ACTION

WILLIE STARTS TO WALK AWAY

Don't poke w/
pitchfork

Show Willie
cont. on after
line.

TRANS.

Willie further
away looking
over shoulder.

DIAL

WILLIE

TRANS.

But don't be readin' my mind between
four and five.

That's Willie's time.

NOTES

FILM ROMAN

THE SIMPSONS

TITLE _____

SHOW 2F03

ACT I

PAGE 21

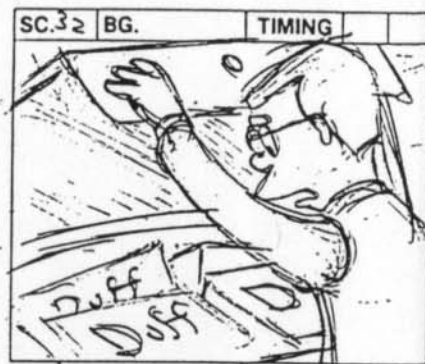
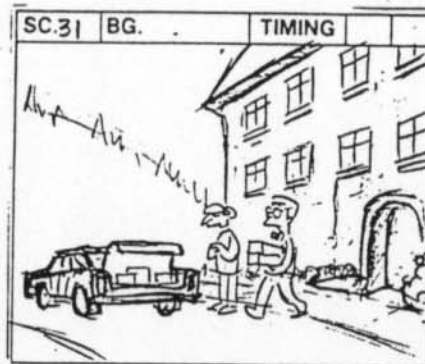
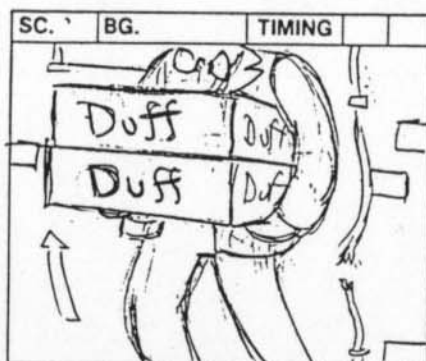
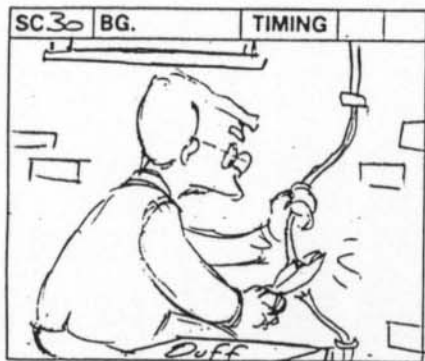

ACTION

SMITHERS CUTS TV CABLE

PICKS UP CRATES OF DUFF

EXT. REAR OF RETREAT

SMITHERS PUTS BEER IN TRUNK

EXT. RETREAT

Smithers cuts the TV cable, and packs the final cases of beer into the back of Burns' limo.

lights on Burns, pull wide.

TRANS.

Fade in on Burns.

BURNS CONT.

DIAL

BURNS

Yes, by cutting off cable TV and the beer supply,

I can ensure an honest

winter's work out of those low-lives.

SMITHERS

Sir, did you ever stop to think that maybe it was doing this that caused the previous caretakers to go insane and

TRANS.

NOTES

FILM ROMAN

THE SIMPSONS

TITLE _____

SHOW 2F03

ACT I

PAGE 22

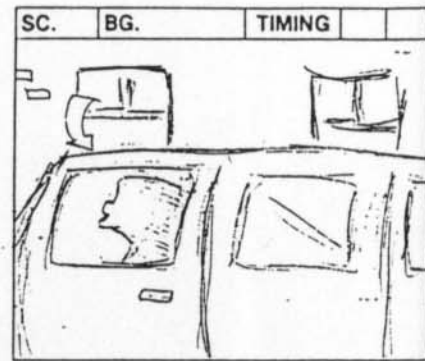
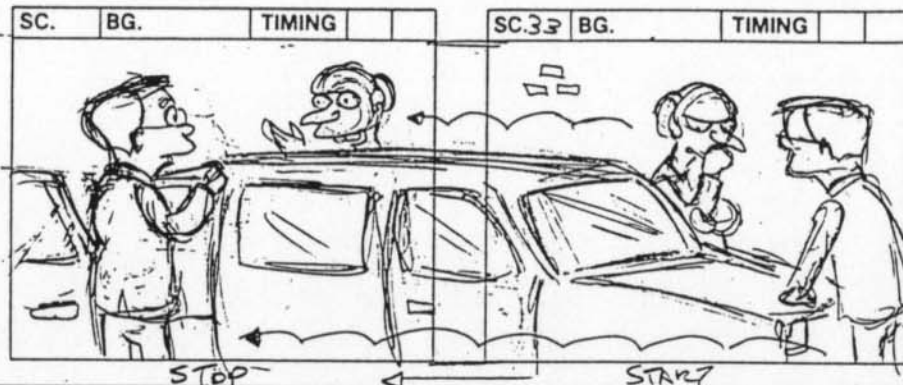

ACTION

SLAMS TRUNK REVEALING BURNS

THEY GET IN CAR,
DRIVE O.S.
They drive off.



TRANS.

DIAL

SMITHERS
murder their families?

(THEN)

Tell you what. We come back and everyone's slaughtered, I owe you a coke.

BURNS

(CONSIDERING) Hmm, perhaps.

TRANS.

NOTES

FILM ROMAN

THE SIMPSONS

TITLE _____

SHOW 2F03

ACT I

PAGE 23

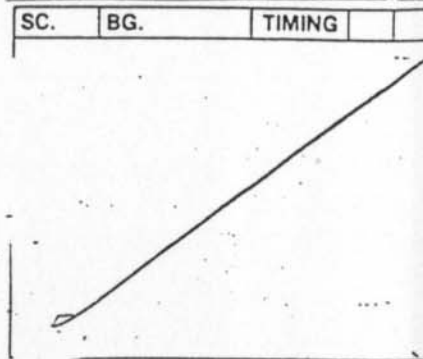
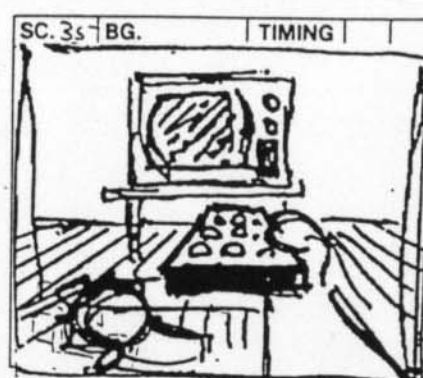
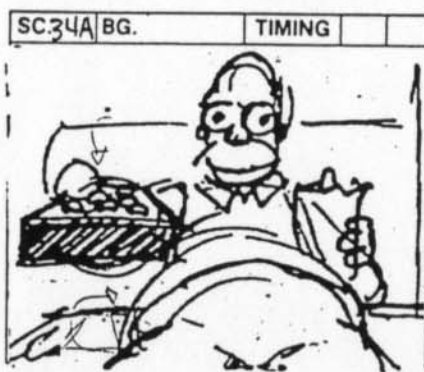
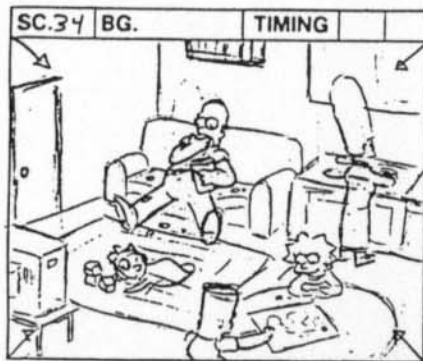

ACTION

Slow Track IN ON
HOMER'S ROOM

HOMER HOLDS UP REMOTE

SEVERAL CHANNELS OF

STATIC

INT. CARETAKERS QUARTERS - LATER

but there is nothing but fuzz.

TRANS.

It's small and dreary. Homer is sprawled on the sofa, stuffing his mouth with potato chips, making a mess. He turns on the TV, with the remote. He flips the channels around,

add est. shot?

DIAL

TRANS.

NOTES

FILM ROMAN

THE SIMPSONS

TITLE _____

SHOW 2F03

ACT I

PAGE 24

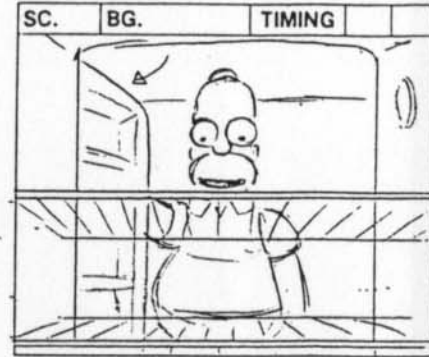
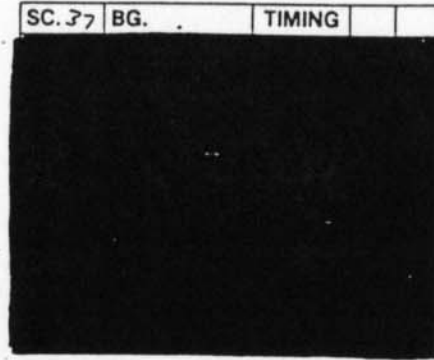
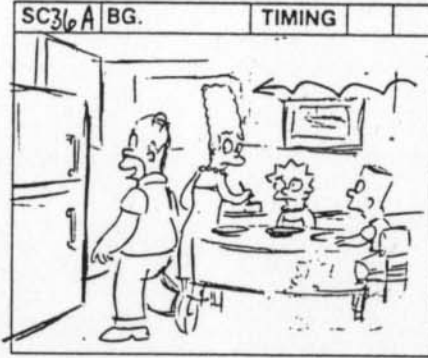

ACTION

36A

SECRET INSIDE OF FRIDGE

He opens the refrigerator. It's empty.

TRANS.

DIAL

HOMER

(PLEASANTLY) Hm, cable's out...

Think I'll have a beer.

HOMER (CONT'D)

(CALM) Hm, not a drop in the house.

TRANS.

NOTES

FILM ROMAN

THE SIMPSONS

TITLE _____

SHOW 2F03

ACT I

PAGE 25

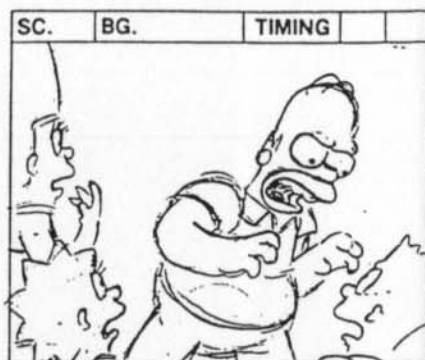
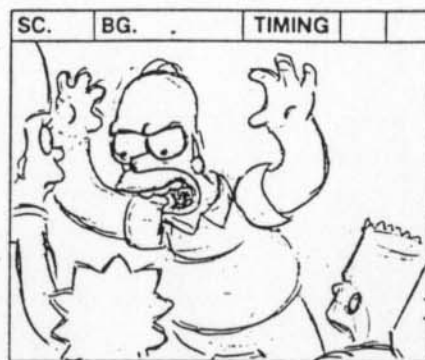
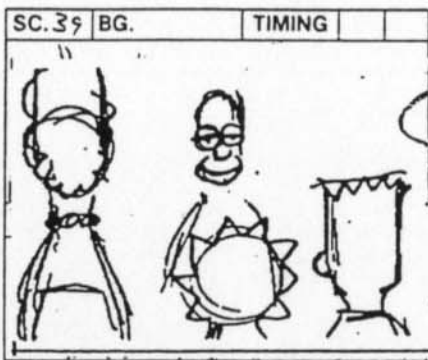
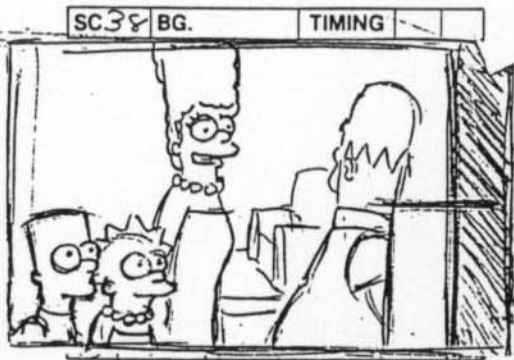

ACTION



TRANS.

HOMER

What do ya know?

DIAL

MARGE

(IMPRESSED MURMUR) Homer, I'm impressed. You're taking this quite well.

TRANS.

NOTES

Faster

~~no heat~~

HOMER

(BEAT, THEN) I'll kill you!

I'll kill all of you!

FILM ROMAN

THE SIMPSONS

TITLE _____

SHOW 2F03

ACT I

PAGE 26

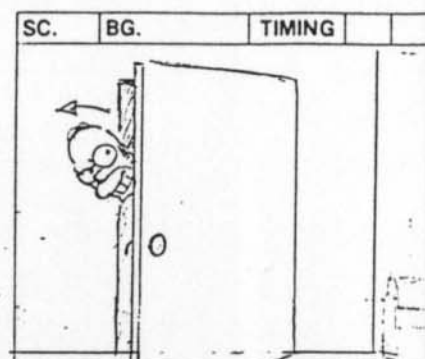
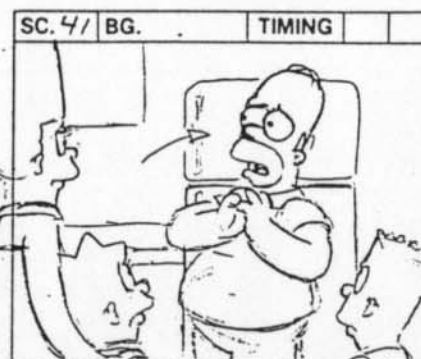
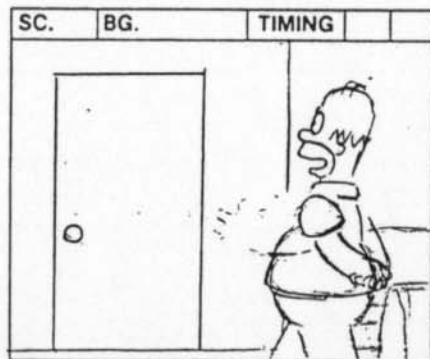
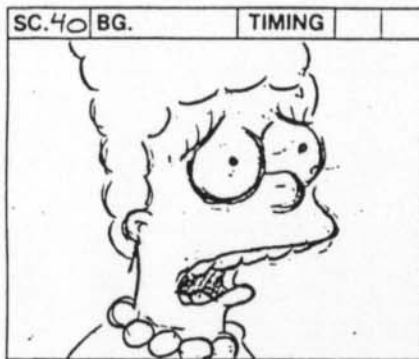

ACTION

STOP

PAN W/ HOMER
TO DOOR

START

TRANS.

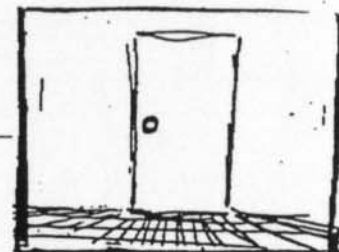
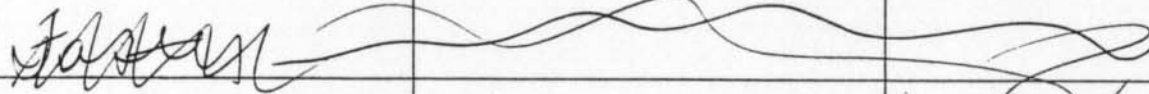

DIAL

MARGE
Homer!

Maybe I'll check out that
axe collection.

HOMER
Sorry, sorry. Don't worry, there's
plenty I can do to keep myself
occupied.

(CRAZY) See ya later.

TRANS.

Not so
toothy

NOTES

FILM ROMAN

THE SIMPSONS

TITLE _____

SHOW 2F03

ACT I

PAGE 27

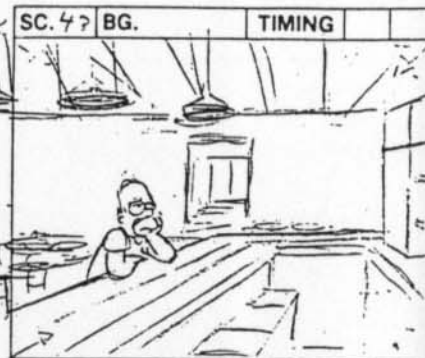
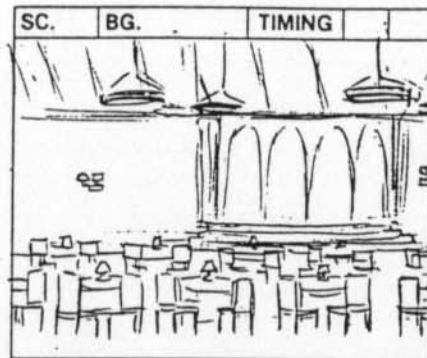
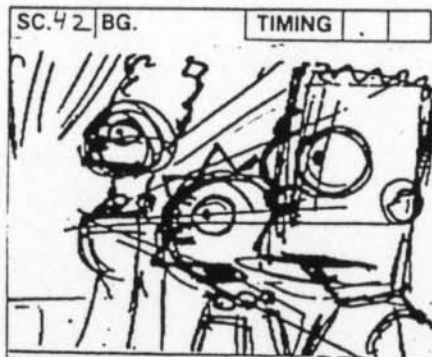
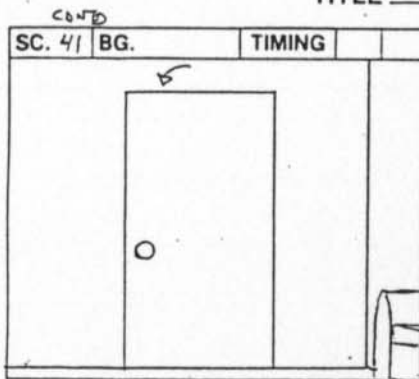

→ PAN TO HOMER

ACTION

SCAMS DOOR
Homer quickly exits.

HOMER AT DESERTED
BAR

INT. GRAND BALLROOM

Homer sits at a deserted bar as ghost of MOE appears.

TRANS.

DIAL

LISA

Mom, is Dad gonna kill us?

TRANS.

MARGE

We're just gonna have to wait and see.

NOTES

FILM ROMAN

THE SIMPSONS

TITLE _____

SHOW 2F03

ACT I

PAGE 28

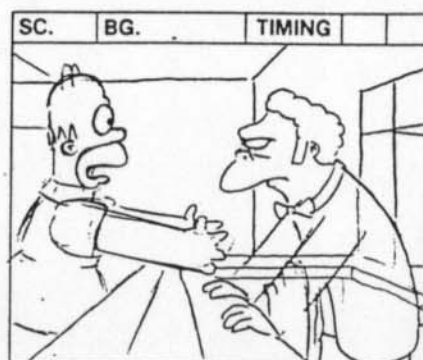
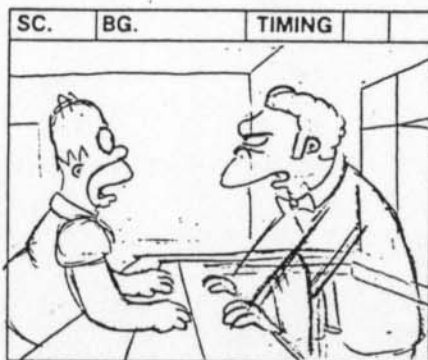
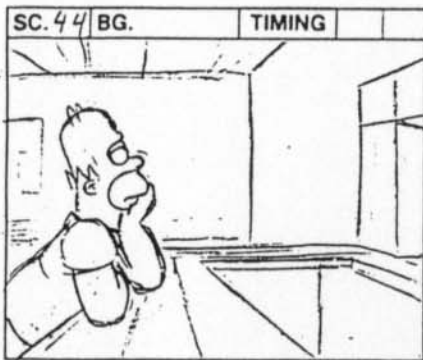

ACTION

MOE APPEARS -
SEMI-TRANSPARENT

LAYOUT -
COMPOSE
LIKE
THIS →



two shot

TRANS.

DIAL

MOE.

So what'll it be, Homer?

HOMER

Moe! Give me a beer!

MOE

No. Not unless you kill your family.

TRANS.

NOTES

FILM ROMAN

THE SIMPSONS

TITLE _____

SHOW 2F03

ACT I

PAGE 29

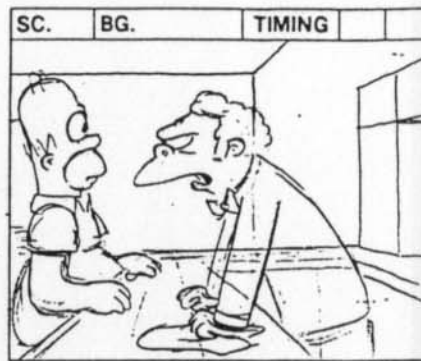
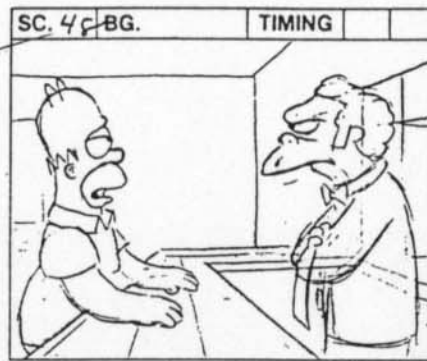
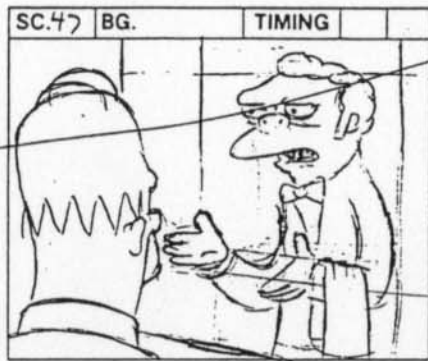
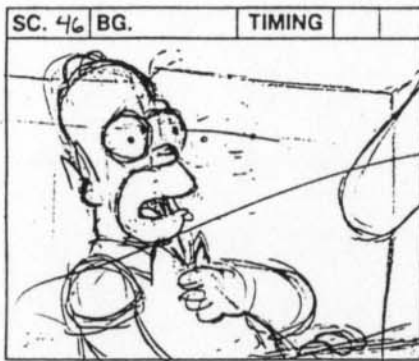

ACTION



TRANS.

two shot

DIAL

HOMER
Why should I kill my family?

MOE
Uh, they'd be much happier as ghosts.

HOMER
You don't look so happy.

MOE
(BITTERLY) Oh, I'm happy. I'm very happy.

TRANS.

NOTES

FILM ROMAN

THE SIMPSONS

SHOW 2F03

ACT I

PAGE 30

TITLE _____

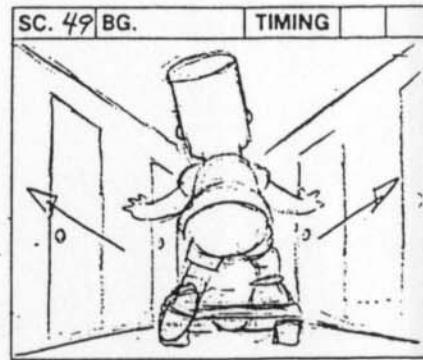
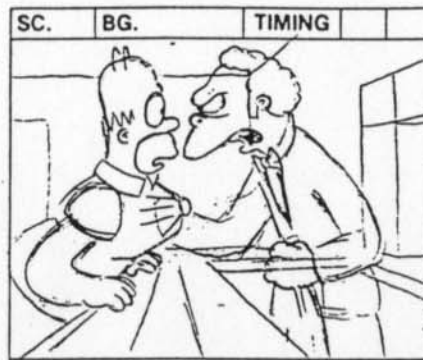
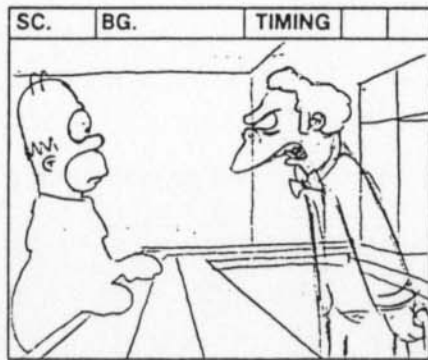
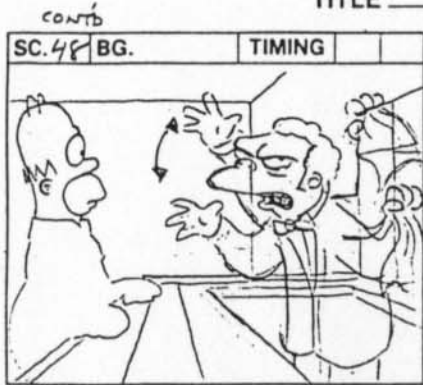

ACTION

MOE GRABS HOMER

BART SKATING DOWN HALL —
ANIMATED BACKGROUND

TRANS.

INT. HALLWAY

We see Bart skateboarding down the hall.

DIAL

MOE
La, la, la, la, la.

See?

Now
waste your family and I'll give you a
beer!

TRANS.

NOTES

FILM ROMAN

THE SIMPSONS

TITLE _____

SHOW 2F03 ACT I PAGE 31

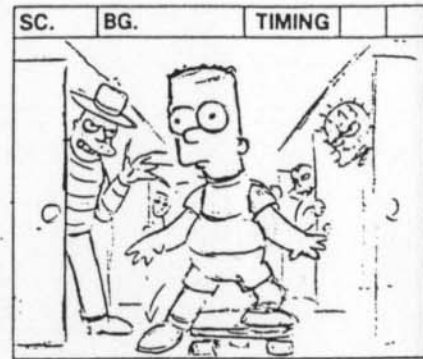
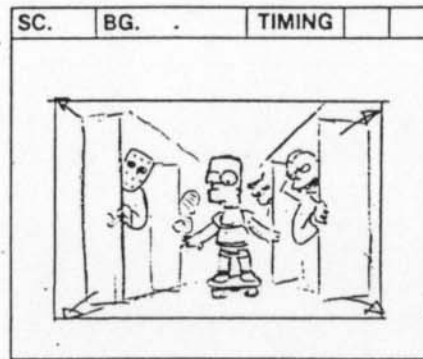
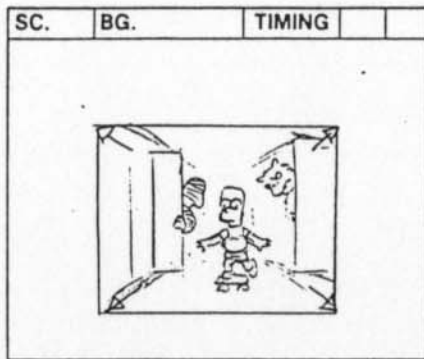
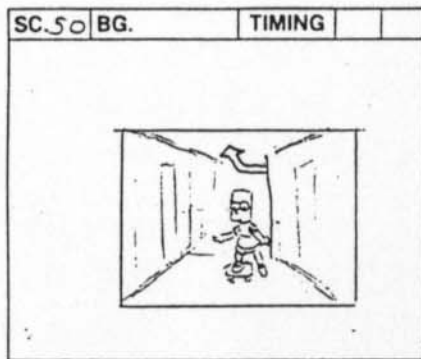

ACTION

BART AROUND CORNER

MONSTERS PEEK OUT FROM BEHIND DOORS

Behind Bart we see all the doors open and various monsters peek out including the WOLFMAN, the MUMMY, JASON, DRACULA, FREDDY KRUEGER, PINHEAD.

BART STOPS

TRANS.

DIAL

TRANS.

NOTES

FILM ROMAN

THE SIMPSONS

TITLE _____

SHOW 2FD3 ACT I PAGE 32

CONT'D

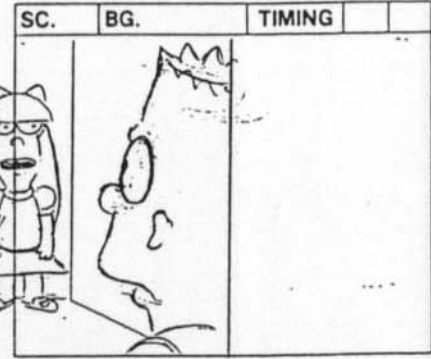
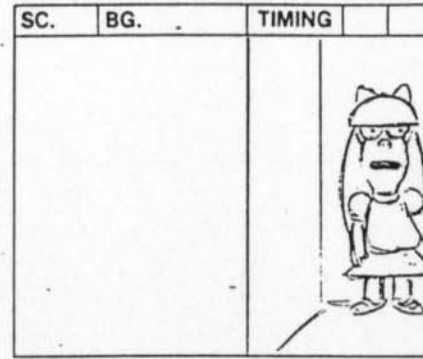
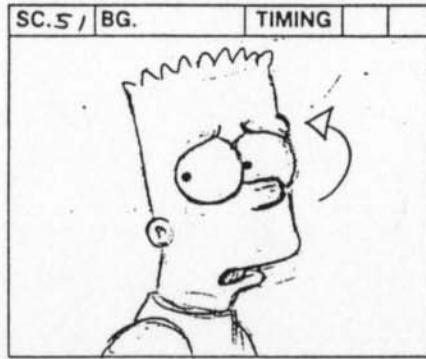
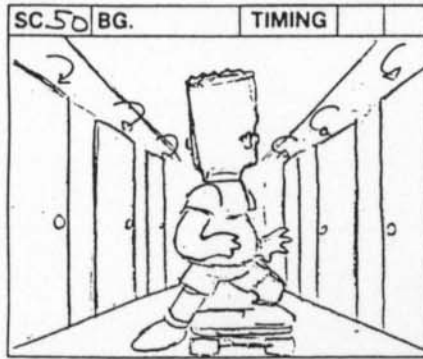

ACTION

Bart senses something and turns around.
All the monsters instantly SLAM their doors shut.

PAN TO SHERRI + TERRI

Bart turns to see a ghost SHERRI and TERRI at the end of the hallway. Bart GASPS and quickly stops his skateboard.

TRANS.

DIAL

BART

(CURIOUS GRUNT)

SHERRI/TERRI

(EERIE SINGING) Your daddy's gonna kill you... (SCARY LAUGH)

TRANS.

NOTES

FILM ROMAN

THE SIMPSONS

TITLE _____

 SHOW 2F03

 ACT I

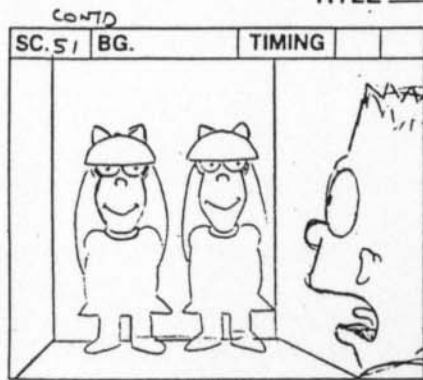
 PAGE 33

STAN7

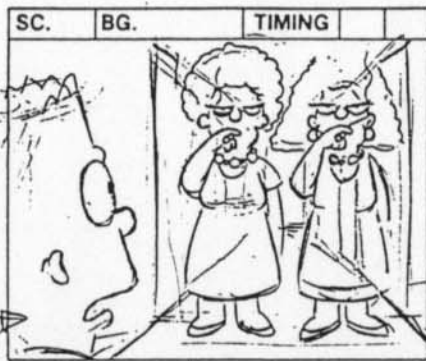

L2 2 10

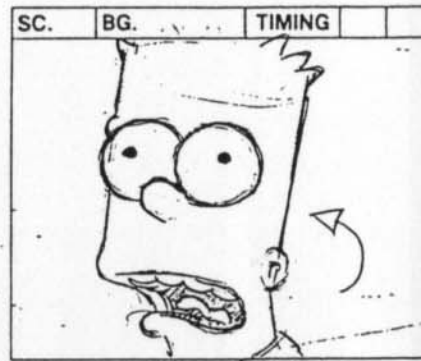

ADJUST ←

ACTION

PAN TO PATTY AND SELMA

SMOKE OUT OF HOLES IN NECKS

BART TURNS TOWARDS CAM.

Bart SCREAMS, turns around and sees ghosts of PATTY and SELMA smoking cigarettes with smoke coming out of holes in their throats (a la Beetlejuice).

TRANS.

DIAL

PATTY/SELMA

They're right, you know.

TRANS.

NOTES

FILM ROMAN

THE SIMPSONS

TITLE _____ SHOW 2F03 ACT I PAGE 34

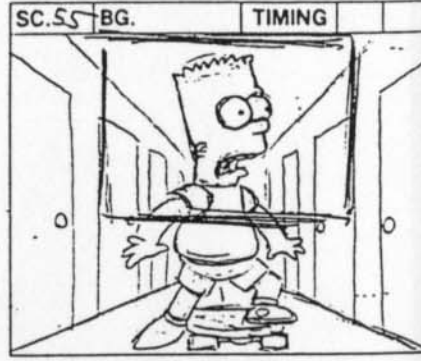
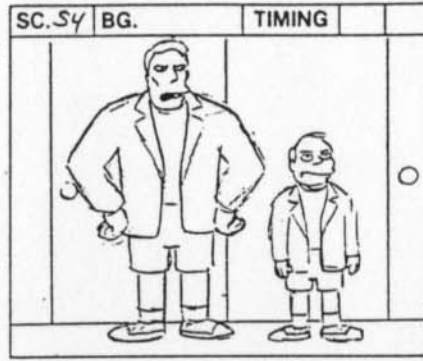
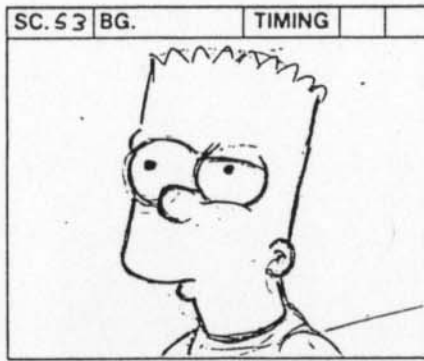
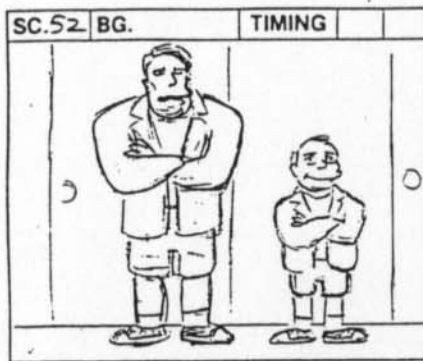

ACTION



OR LIKE
MOVIE
POSTER?

BART LOOKS SKEPTICAL

Bart SCREAMS and skateboards down the hall.

TRANS.

Bart turns again only to be confronted by ARNOLD SCHWARZENEGGER and DANNY DEVITO wearing identical jackets and shorts. Bart SCREAMS.

*still afraid
frozen*

DIAL

Hey, what are you looking at? We're twins too. We have a right to be here.

SCHWARZENEGGER

I'd believe them if I were you.

TRANS.

NOTES

FILM ROMAN

THE SIMPSONS

TITLE _____

SHOW 2F03

ACT I

PAGE 35

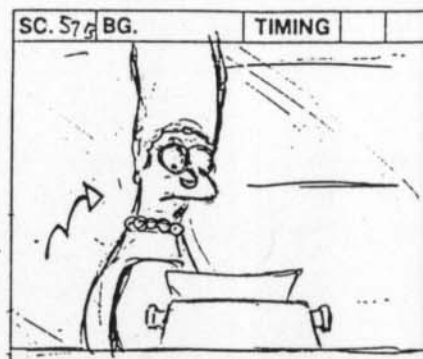
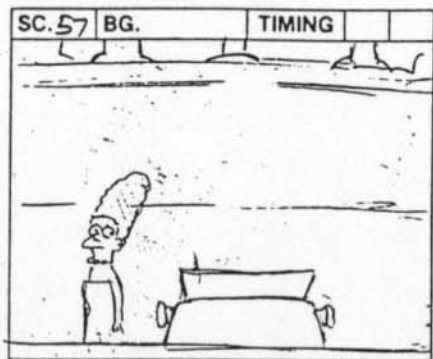
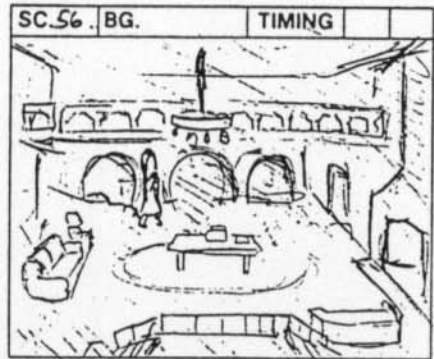
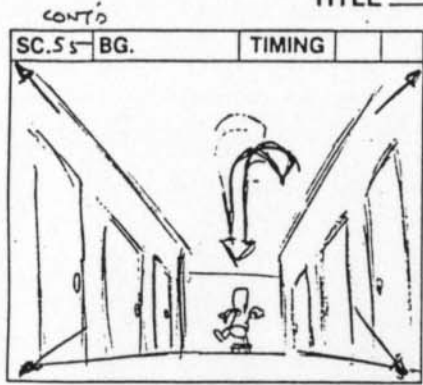

ACTION

BART SKATES DOWN HALL FAST
QUICK TWICK OUT

MARGE ENTERS DARKENED ROOM -
TABLE LIT BY CEILING LAMP
INT. FIRST FLOOR - TV ROOM

Looks around first

MARGE WALKS UP TO TABLE
pull over to reveal typewriter

TRANS.

Marge slowly enters the darkened room. In front of her, eerily lit by a single lamp, is a typewriter on a table.



DIAL

Homer!
MARGE

Homie?

Hm... what he's typed will be a window into his madness.

TRANS.

NOTES

FILM ROMAN

THE SIMPSONS

TITLE _____

SHOW 2F03

ACT I

PAGE 36

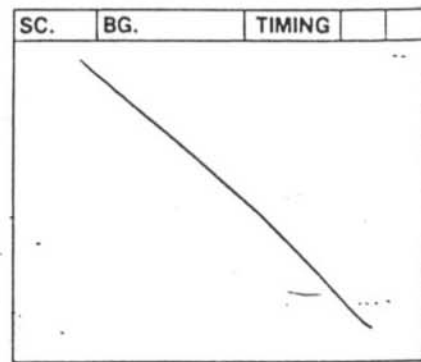
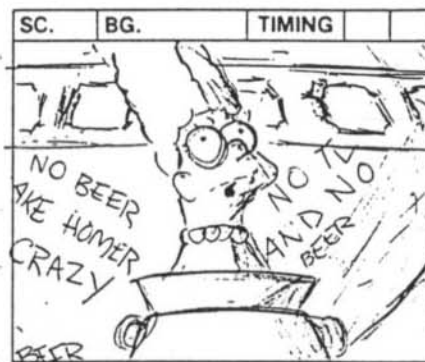
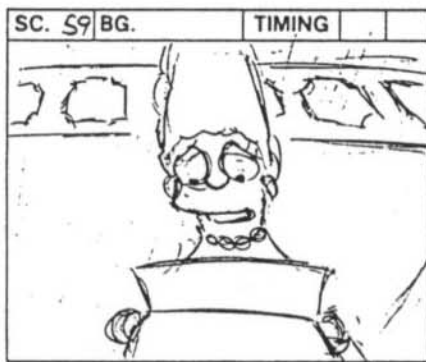
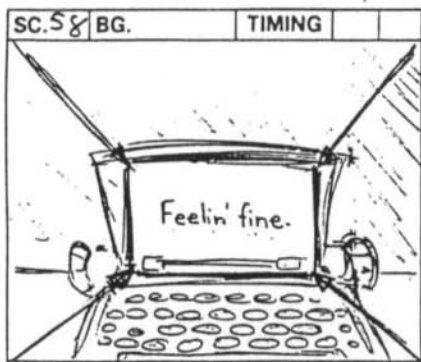

ACTION

TRUCK IN ON PAPER.

We see Marge's POV as she walks slowly over to the typewriter. She sees Homer's typed: "Feelin' fine."

LIGHTNING FLASH

MARGE LOOKS UP

An extended flash of lightning illuminates the room.

TRANS.

DIAL

MARGE (CONT'D)

Feelin' fine,

well, that's a relief.

TRANS.

NOTES

FILM ROMAN

THE SIMPSONS

TITLE _____

SHOW 2F03

ACT I

PAGE 37



ACTION

PAN ACROSS ROOM - ILLUMINATED BY LONG LIGHTNING FLASHES

We see that written in every available space on the walls, ceiling, and floor: "NO TV AND NO BEER MAKE HOMER GO CRAZY."

TRANS.

slower

DIAL

MARGE (CONT'D)

(GRUNTS) This is less encouraging.

TRANS.

NOTES

FILM ROMAN

THE SIMPSONS

TITLE _____

SHOW 2F03

ACT I

PAGE 38

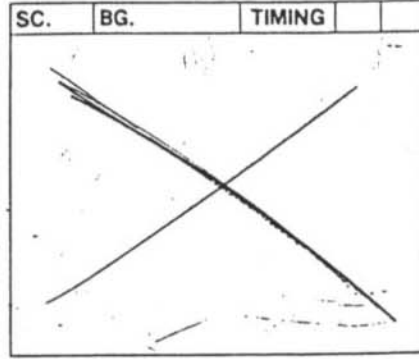
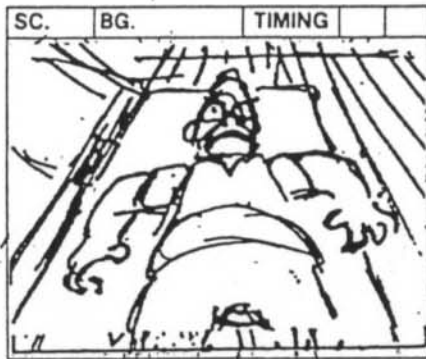

ACTION

DOOR SWINGS OPEN
 LIGHTNING FLASH
 BEHIND HOMER
 In that moment Homer BURSTS into the room. Marge SCREAMS.

TRANS.

DIAL

TRANS.

NOTES

FILM ROMAN

THE SIMPSONS

TITLE _____

SHOW 2F03

ACT I

PAGE 39

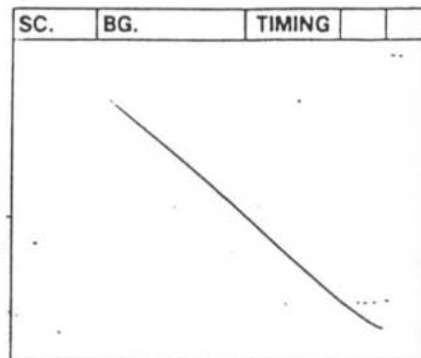
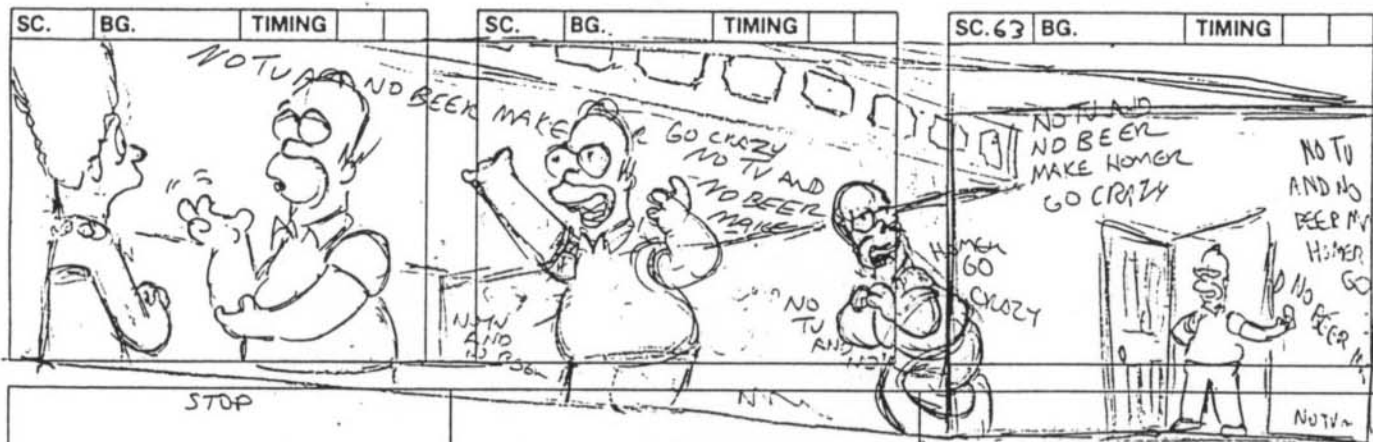

ACTION

STOP

WALKS TO MARGE
WITH NICHOLSON-ESQUE
ACTING

START
HOMER TURNS ON LIGHT

TRANS.

*smaller
movements*

DIAL

HOMER

(RE: CEILING) So, what do you think,
Marge? All I need is a title. I was
thinking along the lines of "No TV and
No Beer Make Homer..." something
something.

TRANS.

NOTES

FILM ROMAN

THE SIMPSONS

TITLE _____ SHOW 2F03 ACT I PAGE 40

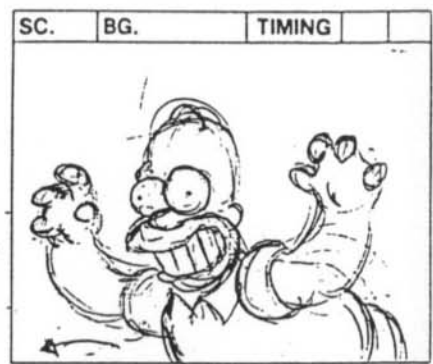
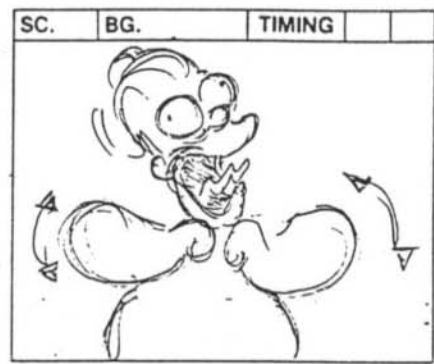
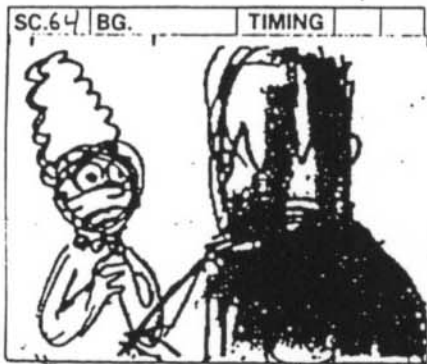

ACTION

backing up - unsettled

STARTS WALKING TOWARDS MARGE

TRANS.



HOMER EVASIVE LOW FOR "DON'T MIND IF I"

PAN UP WITH HOMER ON "DO"

DIAL

MARGE
(WORRIED) Go crazy?

HOMER
Don't mind if I do.

(CRAZY NOISES)

TRANS.

NOTES

FILM ROMAN

THE SIMPSONS

TITLE _____

SHOW 2F03

ACT I

PAGE 41

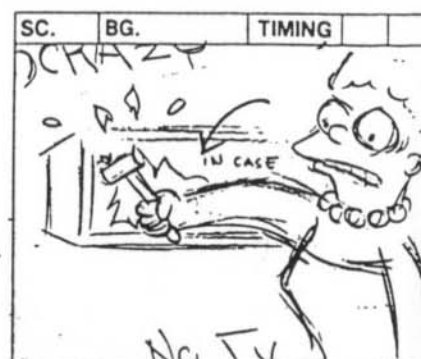
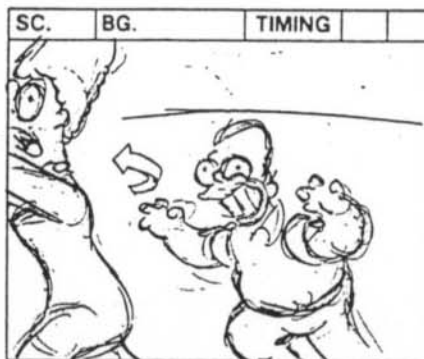
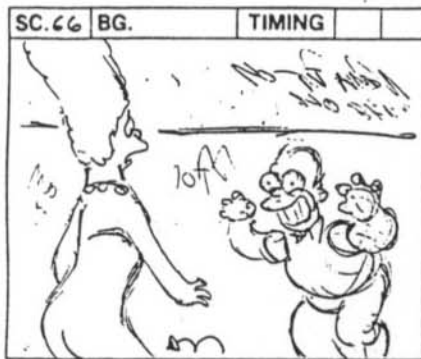

ACTION

HOMER STALKS MARGE - SHE BACKS UP
Homer goes towards Marge menacingly.

MARGE TURNS AND RUNS O-S.
She runs over to a glass case in the

wall holding a baseball bat. A sign reads: "BREAK GLASS IN CASE OF SPOUSAL INSANITY."

MARGE SHATTERS GLASS
Marge BREAKS the glass and grabs the bat.

TRANS.

freeze frame

DIAL

TRANS.

NOTES

FILM ROMAN

THE SIMPSONS

TITLE _____

SHOW 2F03 ACT I PAGE 42

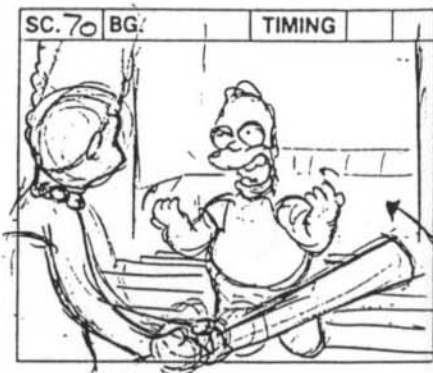
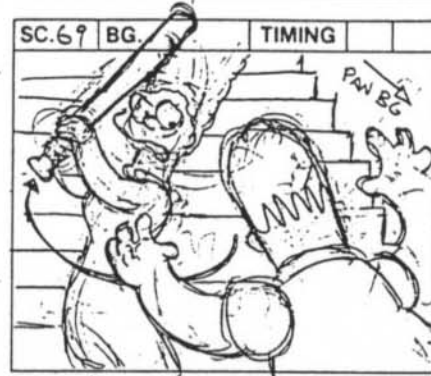
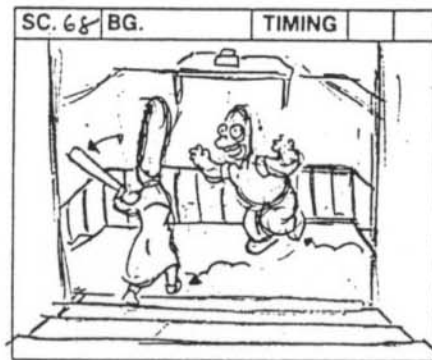
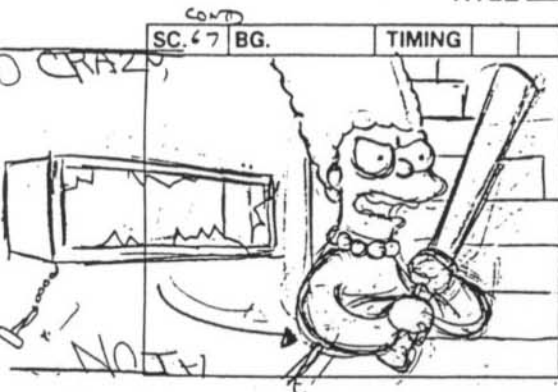

ACTION

PULLS OUT BAT

HOMER BACKS MARGE
UP STAIRCASE

SWINGS BAT BACK AND
FORTH

TRANS.

*Truck in
on Marge*

DIAL

MARGE
Stay away from me, Homer!

HOMER
Gimme the bat, Marge.

Gimme the bat!

Gimme the bat!

TRANS.

NOTES

FILM ROMAN

THE SIMPSONS

TITLE _____

SHOW 2F03

ACT I

PAGE 43

Cont'd

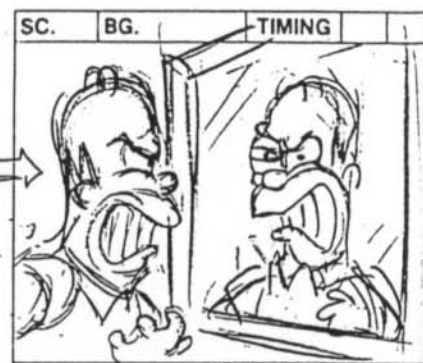
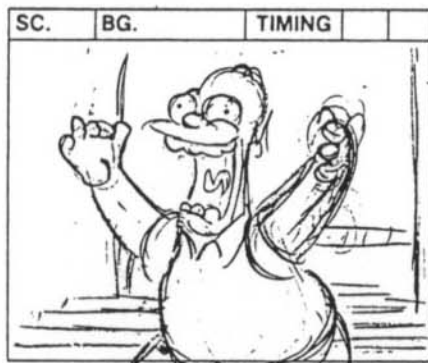
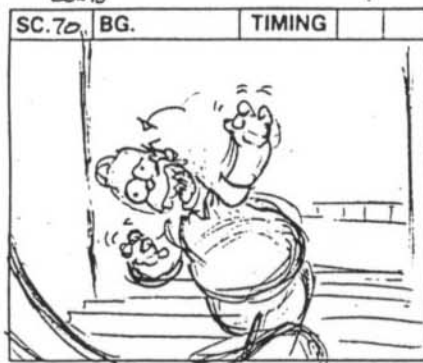

ACTION

MARGE SLOWLY GAINS OUT OF SC.

HOMER MAKES
NICHOLSON-ESQUE
FACES



MORE SCARY
FACES
IN LAYOUT



HEH HEH -
SCAREDY CAT!

HOMER TURNS, LOOKS AT
MIRROR

TRANS.

Homer continues moving toward Marge and making scary Nicholson-esque faces and SILLY NOISES. Marge backs up the staircase. Homer's faces eventually become bigger and more exaggerated.

Homer makes his ugliest face, then looks over his shoulder and sees the face in a mirror, which scares him.

DIAL

C'mon, gimme the bat.

Gimme the bat ba-at!

HOMER
(LAUGHS) Heh-heh. Scaredy-cat...

*faces
mirror.*

TRANS.

NOTES

FILM ROMAN

THE SIMPSONS

TITLE _____

SHOW 2F03

ACT I

PAGE 44

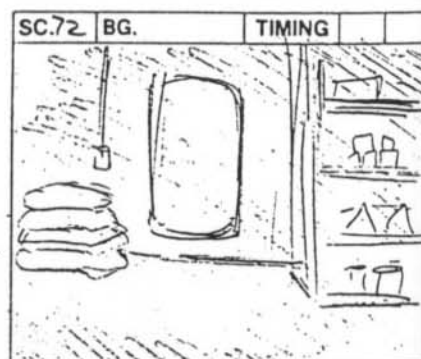
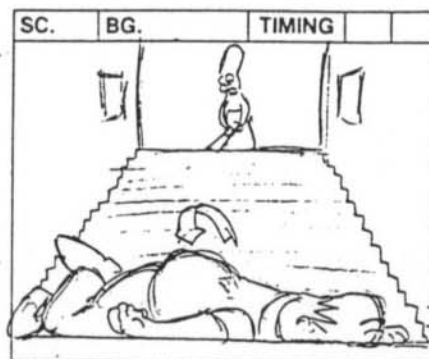
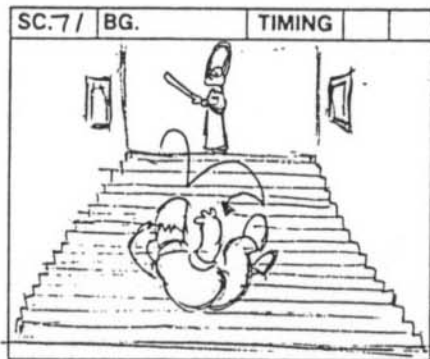
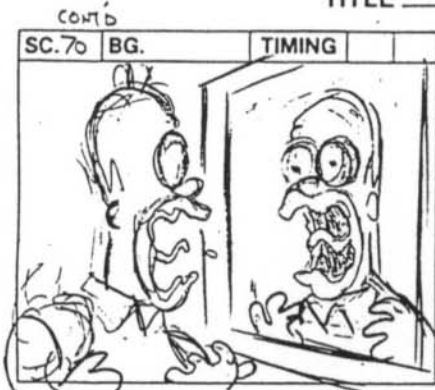

ACTION



HOMER FALLS DOWN STAIRS

Homer falls over backwards and down the steps, knocking himself out.

LIGHTS OFF IN PANTRY

INT. KITCHEN

TRANS.

HOMER FALLS BACKWARDS

smashes head on ground

DIAL

HOMER (CONT'D)
(TERRIFIED SHRIEK)

TRANS.

NOTES

FILM ROMAN

THE SIMPSONS

TITLE _____

SHOW 2F03

ACT I

PAGE 45

CONT'D

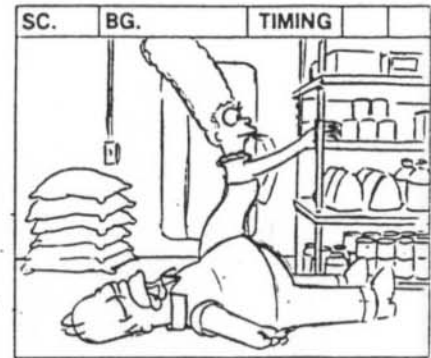
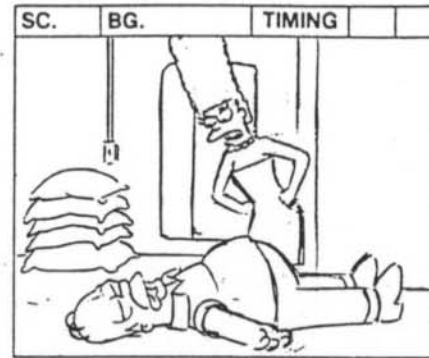
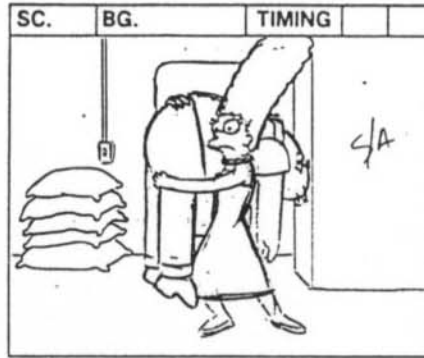
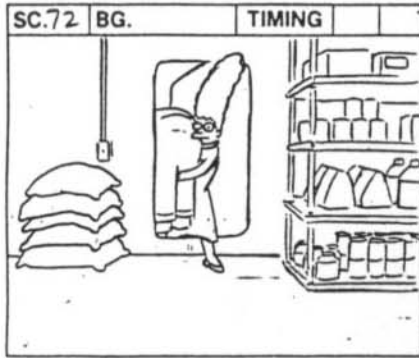

ACTION

Marge carries Homer on her back, into the pantry, dumps him on the floor.

MARGE GRABS CAN

TRANS.

Marge struggles

DIAL

MARGE

You stay here 'til you're no longer insane.

(LOOKING AT SHELF) Mmmm, chili

would be good tonight.

TRANS.

NOTES

FILM ROMAN

THE SIMPSONS

TITLE _____

SHOW 2F03

ACT I

PAGE 46

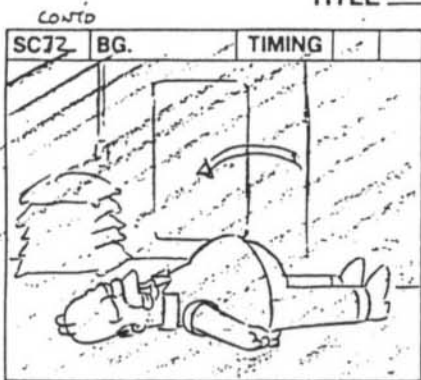

FADE IN

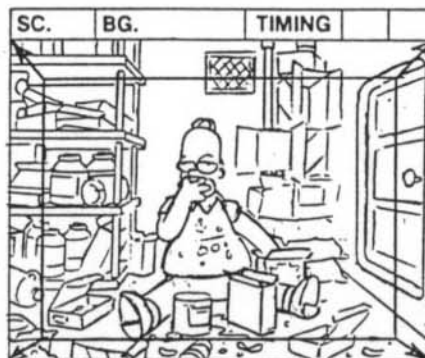

ACTION	<p>MARGE EXITS, SLAMS DOOR - LIGHTS OUT</p> <p>She grabs a can and exits, locking Homer in.</p>	<p>FADE IN:</p> <p>INT. PANTRY</p> <p>Homer, surrounded by lots of open boxes, is rubbing his head and gorging himself on food. There's a KNOCK on the pantry door.</p>	
TRANS.		<p><i>Bags of food, not chili</i></p>	<p><i>Eats as he normally does</i></p>
DIAL		<p>MOE (O.S.)</p> <p>Homer, it's Moe. Ah, look, some of the ghouls and I are a little concerned the project isn't moving forward.</p>	<p>HOMER</p> <p>(MOUTH FULL) Can't murder now. Eating</p>
TRANS.	<p>FADE OUT:</p>		
NOTES			

FILM ROMAN

THE SIMPSONS

TITLE _____

 SHOW 2F03

 ACT I

 PAGE 47

CONTD

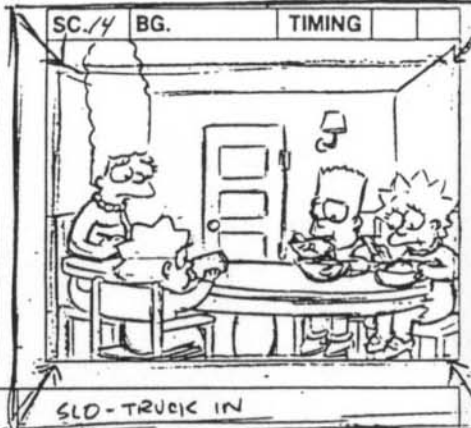
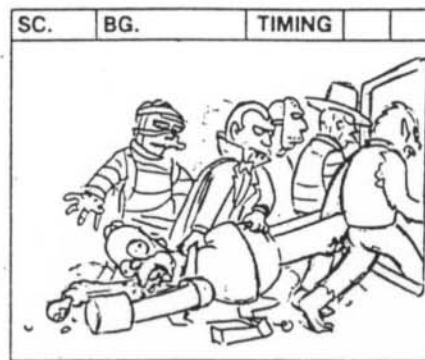
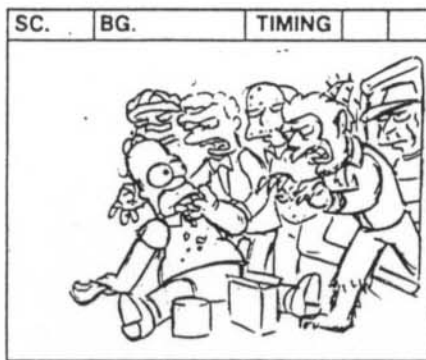
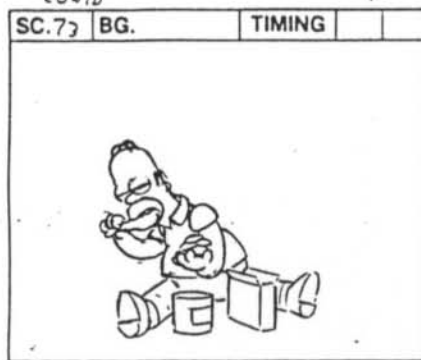

ACTION

Moe and the various monsters and ghouls go inside and try to pull Homer away. Homer resists and tries to continue eating.

INT. RETREAT - KITCHEN

We see the family eating.

TRANS.

DIAL

MOE (O.S.)
Oh, for cryin' out loud.

HOMER
(MOUTHFUL) Noooo!

TRANS.

NOTES

FILM ROMAN

THE SIMPSONS

TITLE _____

SHOW 2F03

ACT I

PAGE 48

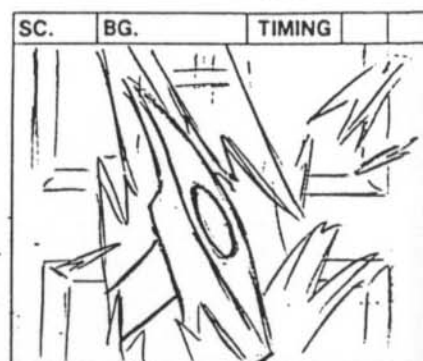
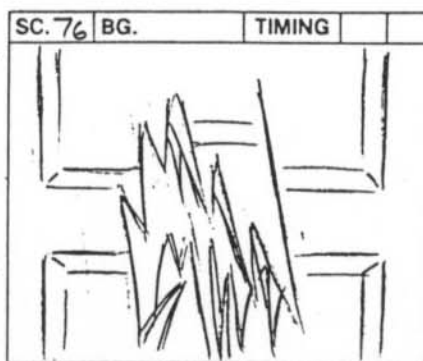
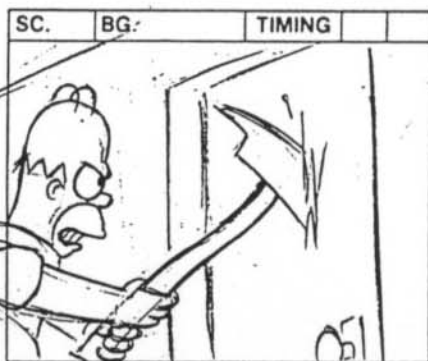
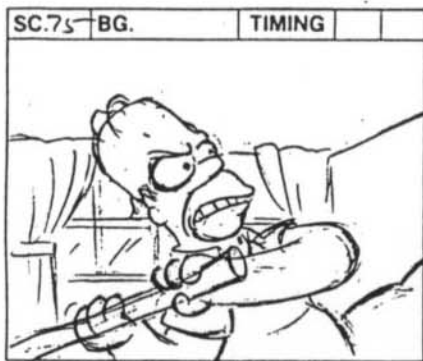

ACTION

PAN WITH AXE TO DOOR

C.U. DOOR

2nd SWING SPLINTERS BIG HOLE IN DOOR

ANGLE ON DOOR

An axe blade comes CRASHING through. Another CROP leaves a large hole.

Another CROP leaves a

TRANS.

add chops,

DIAL

TRANS.

NOTES

FILM ROMAN

THE SIMPSONS

TITLE _____

SHOW 2F03

ACT I

PAGE 49

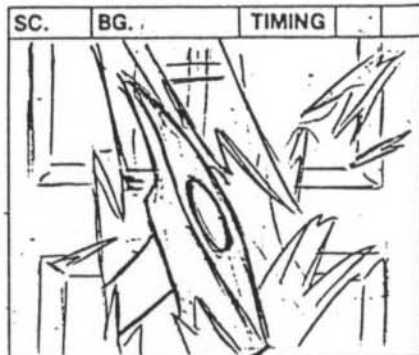
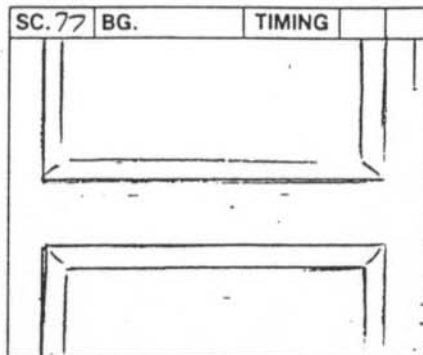
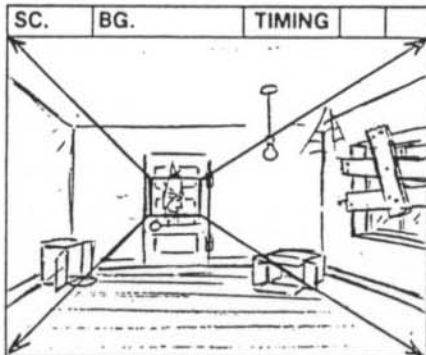
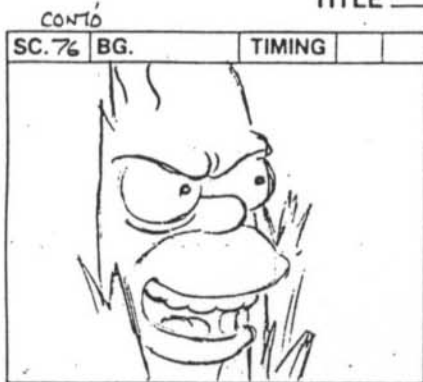

ACTION

Homer's head appears.

DIRECTOR NOTE: I KNOW THIS IS PROBABLY A "FORBIDDEN" EXPRESSION, BUT IT IS FAITHFUL TO THE MOVIE

QUICK TRUCK OUT

We WIDEN to see Homer's broken into an empty room.

ANGLE ON ANOTHER DOOR
The axe rips a hole.

TRANS.

same tight shot.

DIAL

HOMER
Heeeeere's Johnny.

HOMER. (CONT'D)
(ANNOYED GRUNT)

TRANS.

NOTES

FILM ROMAN

THE SIMPSONS

TITLE _____

SHOW 2F03

ACT I

PAGE 50

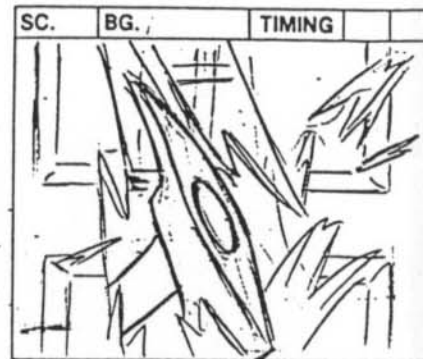
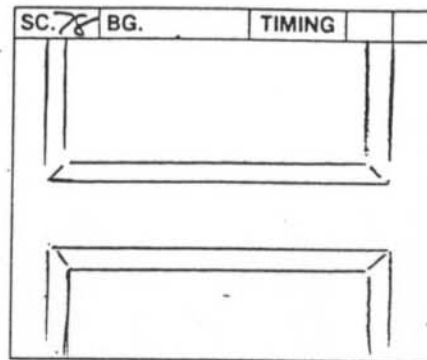
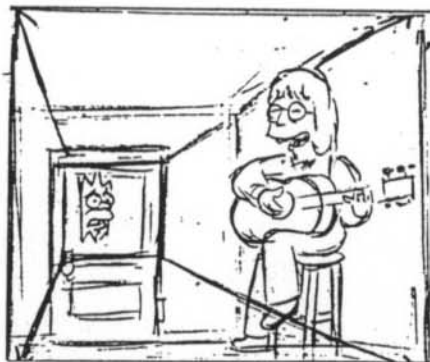
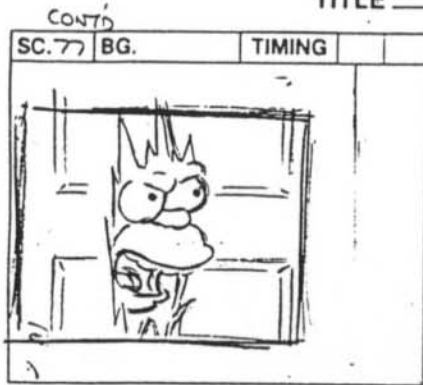

ACTION

Homer sticks his head through.



QUICK TRUCK OUT
TO REUSAL
JOHN DENVER

ANGLE ON ANOTHER DOOR
An axe rips a hole.

TRANS.

WE WIDEN to see John Denver sitting on a stool, PLAYING guitar.

same shot.

DIAL

HOMER
Daaaa-vid Lettermaaaaan!

JOHN DENVER
(SINGING TO THE TUNE OF "YOU FILL UP MY SENSES") "I'm out of the hedgemaze..."

TRANS.

HOMER
(Grossed Out) Yeuh!

NOTES

FILM ROMAN

THE SIMPSONS

SHOW 2F03 ACT I PAGE 51

TITLE _____

CONT'D

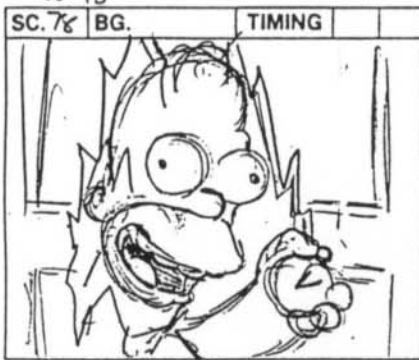

"I'M MIKE WALLACE -"

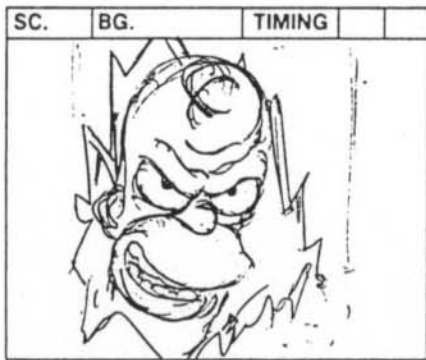

PATENTED KUBRICK LOOK OF INSANITY

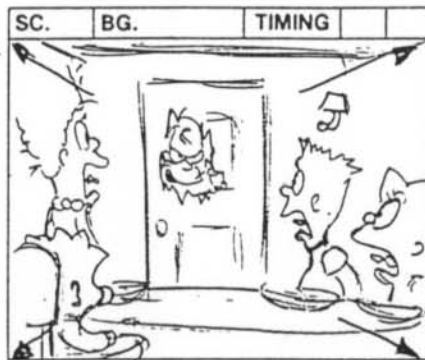

Homer has the patented Kubrick look of insanity. Simpsons SCREAM and run out another door,

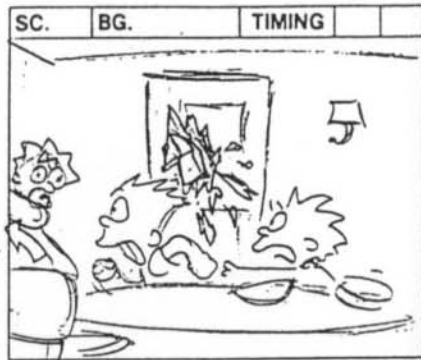

FAMILY RUNS O.S. AS HOMER RESUMES BREAKING DOWN DOOR

ACTION

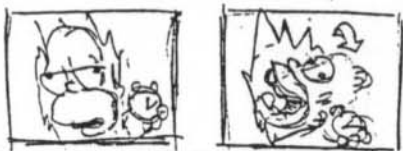

TRANS.

"I'M MORLEY SAFER"
AND I'M ED BRADLEY. ALL THIS AND ANDY ROONEY -

Homer's face appears, holding a TICKING stopwatch.

DIAL

HOMER

I'm Mike Wallace. I'm Morley Safer. And I'm Ed Bradley. All this and Andy

tonight on "60 minutes."

TRA

Rooney

NOTES

Door smashes open.

FILM ROMAN

THE SIMPSONS

TITLE _____

 SHOW 2F03

 ACT I

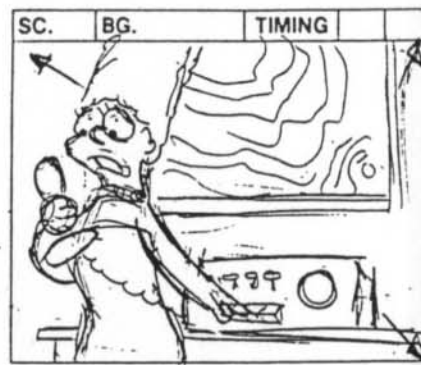
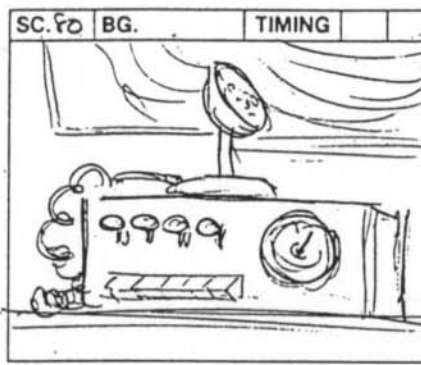
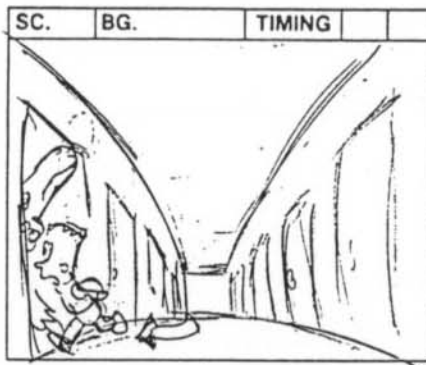
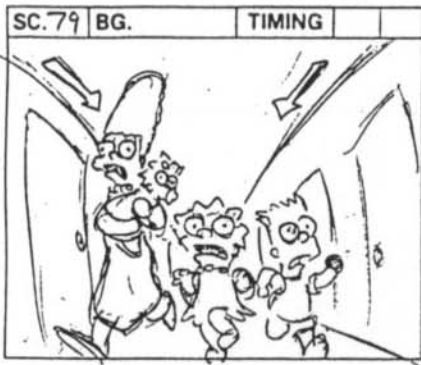
 PAGE 52

ACTION

FAMILY RUNNING DOWN HALL
ANIMATED BG.
down a corridor

RUN INTO DOORWAY

ON RADIO

into a room with a radio.

WIDEN AS MARGE GRABS MIKE

TRANS.

DIAL

MARGE

Hello, police?

TRANS.

NOTES

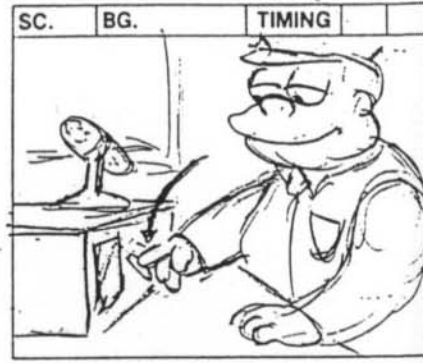
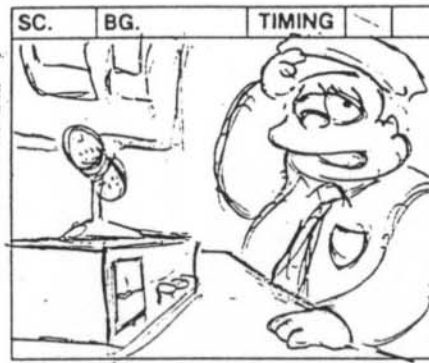
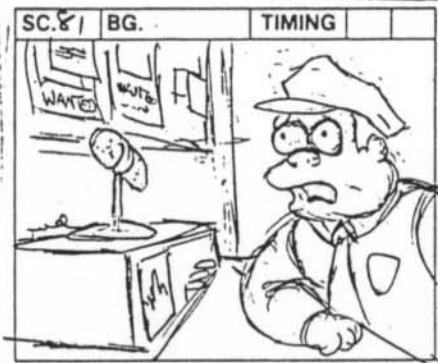
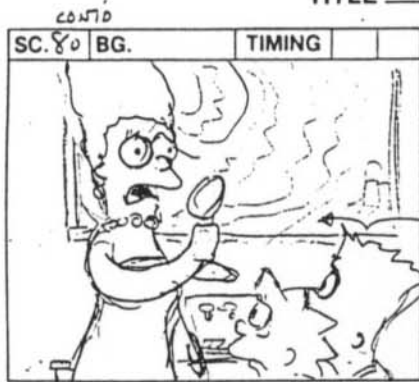

ACTION

WIGGUM LISTENING

INT: WIGGUM'S OFFICE - CONTINUOUS

Wiggum turns off the radio.

TRANS.

*No overexposed
Bigger mic,*

DIAL

This is Marge Simpson.

 My husband is on a murderous rampage.
(BEAT) Over.

WIGGUM

 Oh, well thank God that's over. I was
worried there for a second.

TRANS.

NOTES

FILM ROMAN

THE SIMPSONS

TITLE _____

SHOW 2FD3

ACT I

PAGE 54

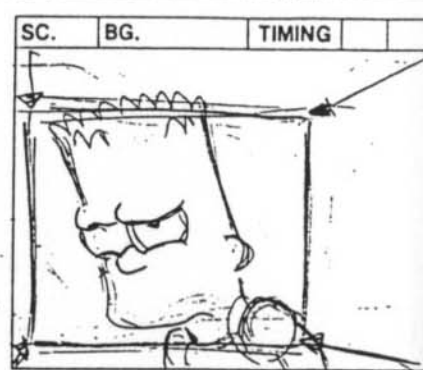
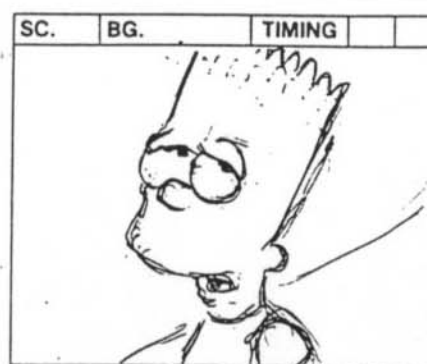
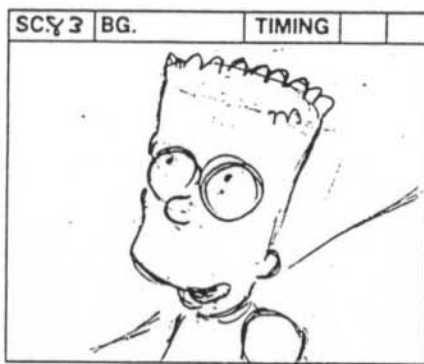
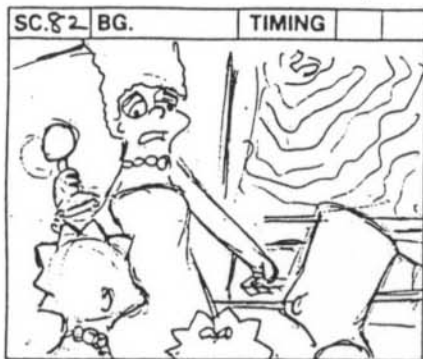

ACTION

INT. RETREAT - CONTINUOUS

TRUCK IN ON BART.

eye roll.

We see Bart concentrate hard.

TRANS.

DIAL

MARGE

No answer.

BART

Don't worry, Mom. I can use my

(ROLLS

EYES BEGRUDGINGLY) "shinning" to call Willie.

TRANS.

NOTES

FILM ROMAN

THE SIMPSONS

TITLE _____

SHOW 2FD3 ACT I PAGE 55

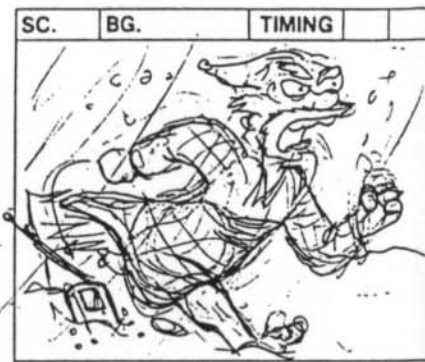
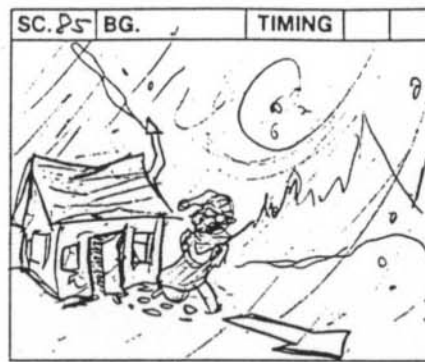
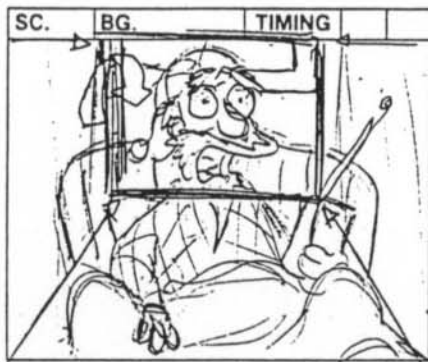
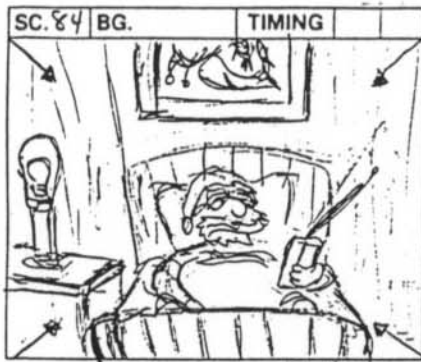

ACTION

INT. WILLIE'S SHACK

Willie, in bed with a WATCHMAN TV, suddenly bolts upright.

BOLTS UPRIGHT

WILLIE RUNS OUT OF SHACK

EXT. SHACK - CONTINUOUS

Willie runs across the snow toward the retreat. (He drops his Watchman TV in the snow.)

DROPS WATCHMAN IN SNOW

TRANS.

SHOW P.O.V.
of TV.

DIAL

GROUNDSKEEPER WILLIE



Uh oh. The little fat boy an' his family're in trouble.

GROUNDSKEEPER WILLIE

(YELLING) I'm comin' to rescue the lot o' ya.

TRANS.

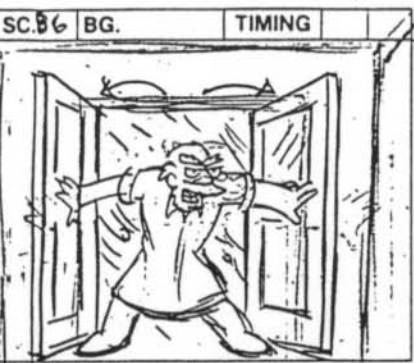
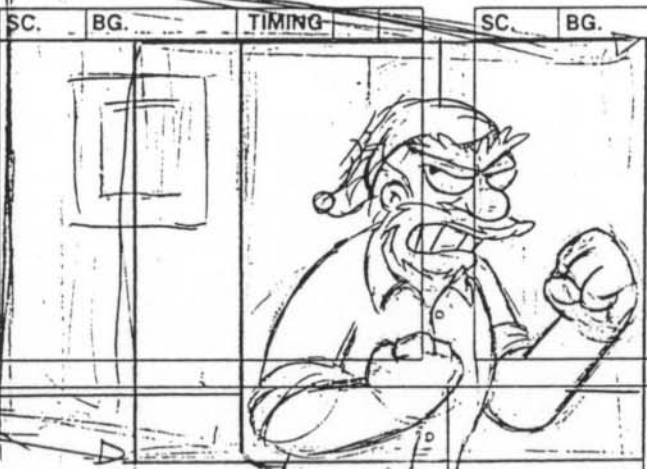
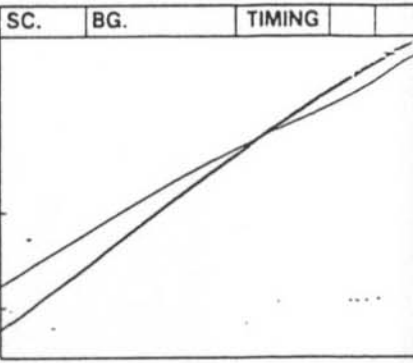
NOTES

TITLE				SHOW				ACT				PAGE			
SC.	BG.	TIMING		SC.	BG.	TIMING		SC.	BG.	TIMING		SC.	BG.	TIMING	
SC. 96	BG.	TIMING		SC.	BG.	TIMING		SC.	BG.	TIMING		SC.	BG.	TIMING	
															
ACTION				ACTION				ACTION				ACTION			
DOORS BURST OPEN				PAN, WITH WILLIE PAST COLUMN											
TRANS.				TRANS.				TRANS.				TRANS.			
															
DIAL				DIAL				DIAL				DIAL			
GROUNDKEEPER WILLIE (CONT'D) All right, looney!				got.				Show me what ya							
TRANS.				TRANS.				TRANS.				TRANS.			
NOTES				NOTES				NOTES				NOTES			

FILM ROMAN

THE SIMPSONS

TITLE _____

SHOW 2F03

ACT F

PAGE 57



ADJUST →

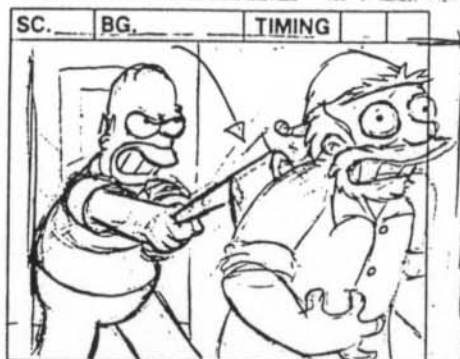

ADJUST RT →

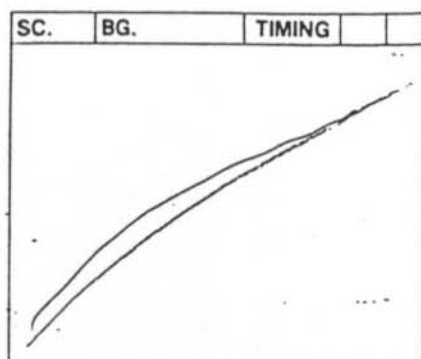
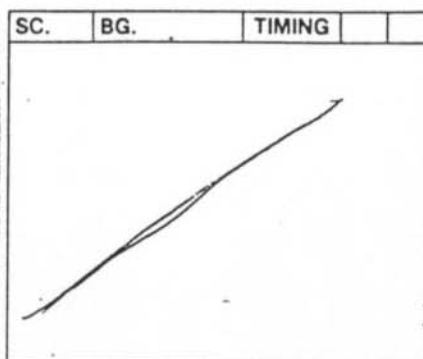

ACTION

WIDEN OUT SLIGHTLY AS HOMER
STEPS OUT FROM BEHIND COLUMN

BURIES AXE IN BACK

Homer steps out from behind a column and plants a huge axe
into Willie's back.

TRANS.

Widen

DIAL

TRANS.

NOTES

FILM ROMAN

THE SIMPSONS

SHOW 2F03 ACT I PAGE 58

TITLE _____

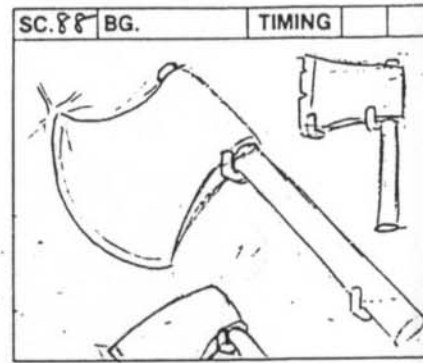
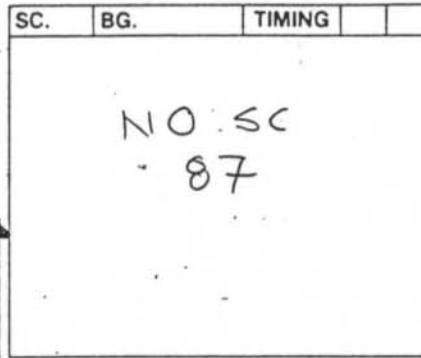
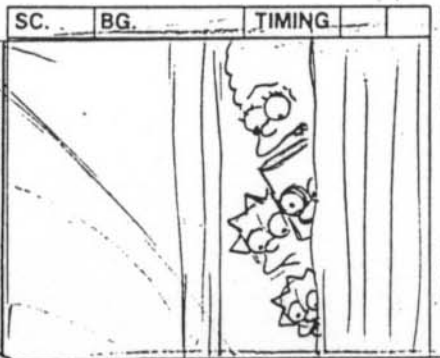

ACTION

START

FAMILY HIDING
BEHIND CURTAIN

PAN UP

C.U. HUGE AXE

TRANS.

*different
exp.*

Willie falls over dead. We see the family has been hiding out watching this.

GROUNDSKEEPER WILLIE (CONT'D)

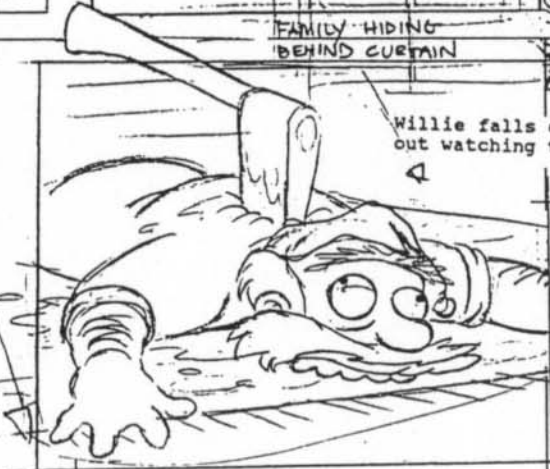

MARGE

Oh my, I hope that rug was
Scotchguarded.

Heh, is that the best you can do?

TRANS.

NOTES

vp

FILM ROMAN

THE SIMPSONS

SHOW 2F03

ACT I

PAGE 59

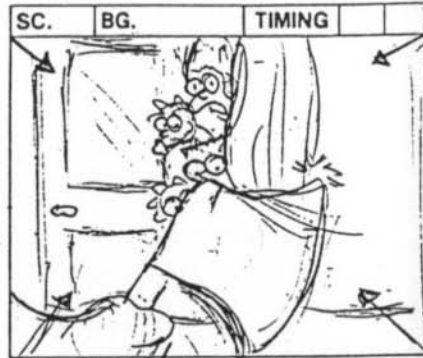
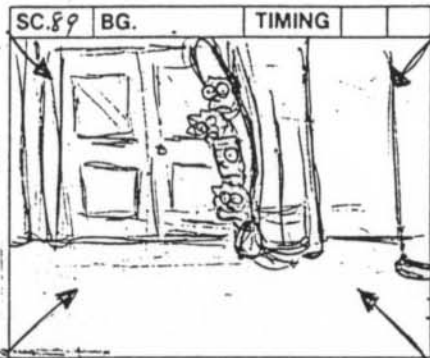
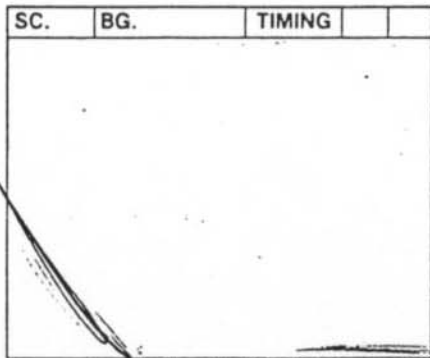
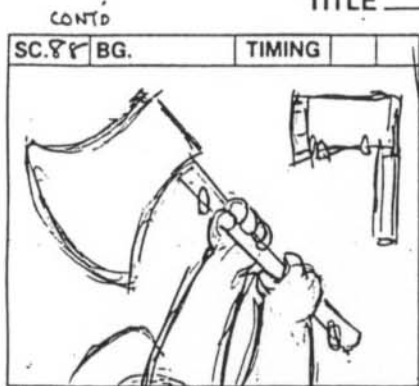

ACTION

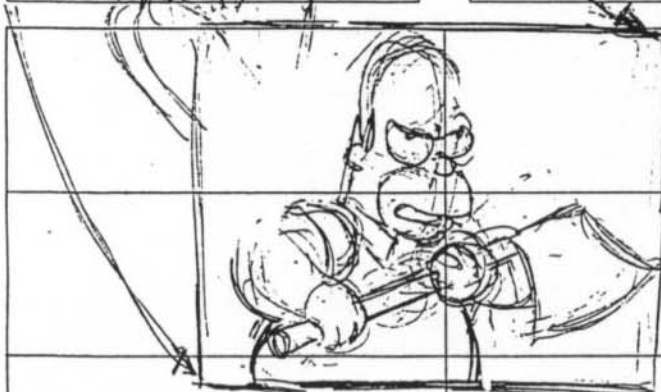

BI-PACK SHOT:
TRUCK IN ON HIDING
FAMILY —

AXE UP INTO FOREGROUND —
FAMILY REACTS

TRANS.

DIAL

HOMER STARTS WAUKING
Homer takes down another huge axe off the wall.

TRUCK IN
ON HOMER'S
HEAD

TRANS.

(EYES ROLLED UP) Must kill
family. (MOANS).

NOTES

FILM ROMAN

THE SIMPSONS

TITLE _____

SHOW 2F03ACT IPAGE 60

CONT'D

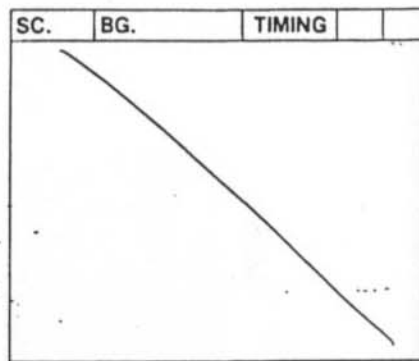
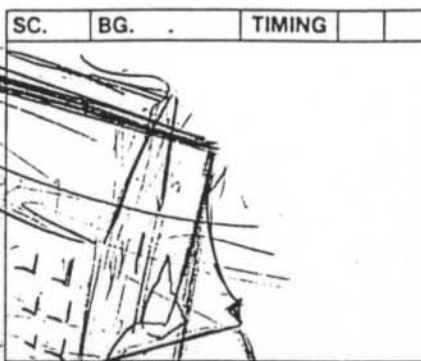
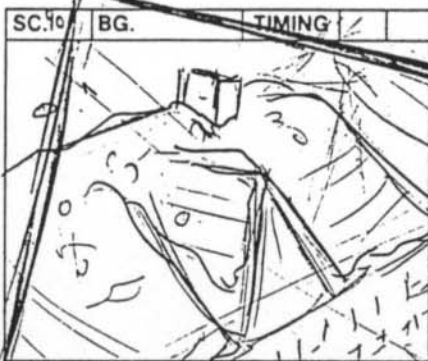
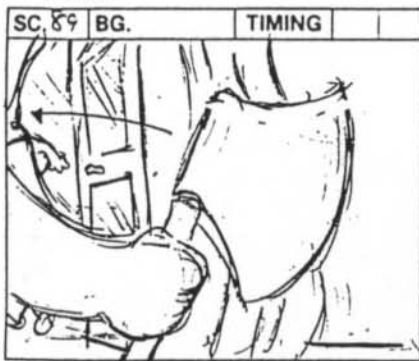

ACTION

FAMILY RUNS OUT
DOOR

TRANS.

DIAL

The family runs outside with Homer in pursuit. They hit deep snow which slows them down as if they're in molasses.

HELICOPTER SHOT-

TWIST TRUCK IN ON FAMILY RUNNING THRU SNOW, PURSUED BY HOMER;

SNOW SWIRLS IN FOREGROUND

TRANS.

NOTES

FILM ROMAN

THE SIMPSONS

TITLE _____

SHOW 2F03

ACT I

PAGE 61

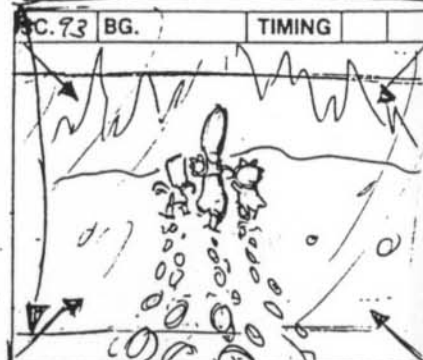
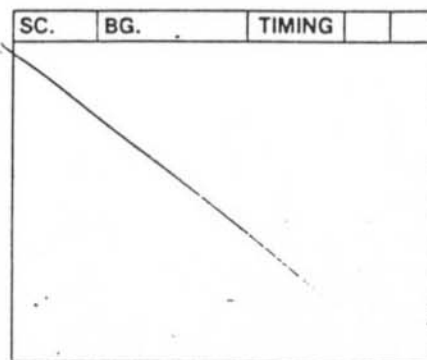
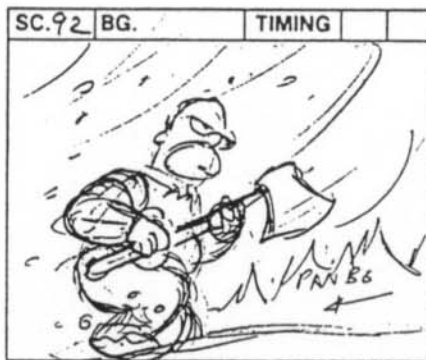

ACTION

FAMILY RUNS, SLOWING DOWN IN PROGRESSIVELY DEEPER SNOW

UPSHOT OF HOMER

Homer is gaining. It looks hopeless.

HOMER'S P.O.V. -
TRUCK IN ON FAMILY WITH WALKING BOUNCE MOTION

TRANS.

DIAL

TRANS.

NOTES

FILM ROMAN

THE SIMPSONS

TITLE _____

SHOW 2F03

ACT I

PAGE 62

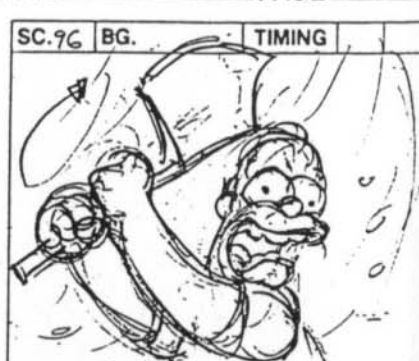
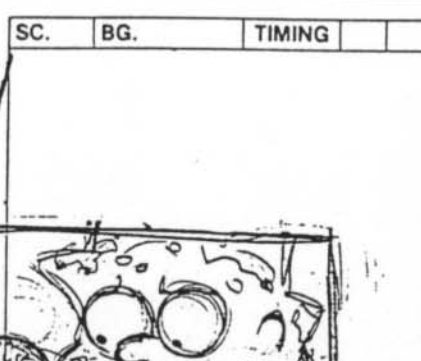
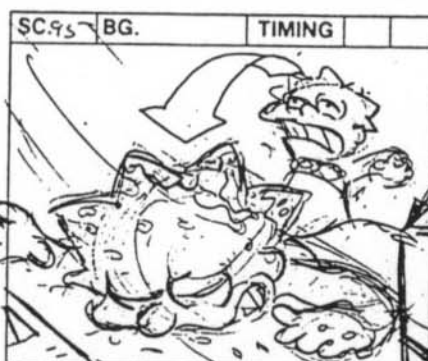
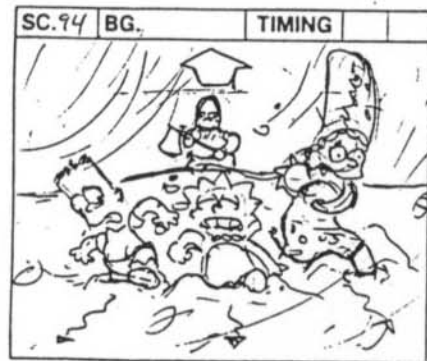

ACTION

FAMILY STUCK IN WAIST-HIGH SNOW - HOMER GAINS IN B.G.

LISA FALLS FACE DOWN IN SNOW



HOMER STEPS UP INTO VIEW, RAISES AXE

TRANS.

Lisa notices Willie's Watchman in the snow.

TRUCK TO TV IN FOREGROUND
~~DRIVE~~

Homer approaches them, axe raised.

DIAL

adjust -
TV in front
of her.

TRANS.

NOTES

FILM ROMAN

THE SIMPSONS

TITLE _____

SHOW 2F03

ACT I

PAGE 63

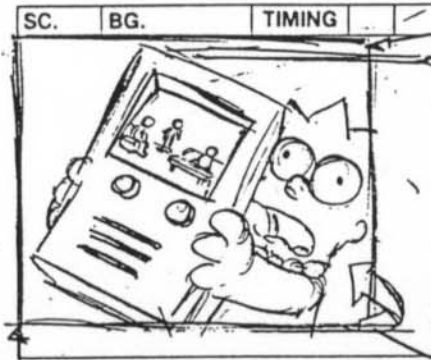
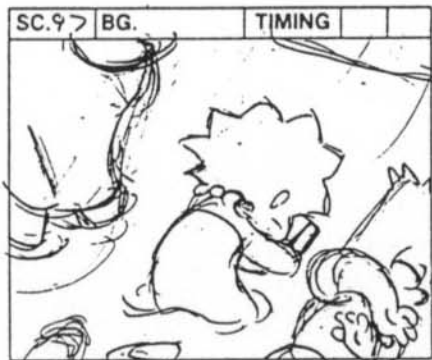
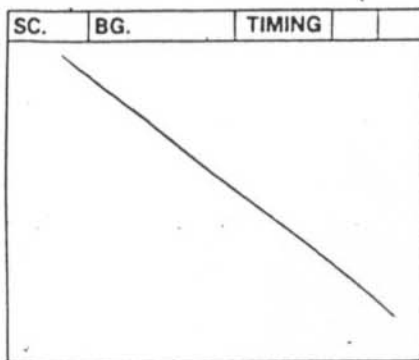

ACTION

Downsnot of Lisa

LISA HOLDS UP TV
(BROCKMAN ON SCREEN?)

At the last moment, Lisa shoves the TV toward
Homer's face.

TRANS.

TV in -
zoom into tv

DIAL

LISA

Dad, look!

TRANS.

NOTES

FILM ROMAN

THE SIMPSONS

SHOW 2FD3

ACT I

PAGE 64

TITLE _____

CONT'D

SC. 98 BG. TIMING



SC. 99 BG. TIMING



SC. BG. TIMING



SC. BG. TIMING



ACTION

The family takes a cautious step toward Homer.

HOMER REGARDS UP - FAMILY JUMPS BACK

TRANS.

Homer drops the axe, grabs the TV and sits down in the snow.

*watch TV
← size.*

Doesn't turn away - "...FADING..."
The family jumps back.



DIAL

HOMER (CONT'D)

Urge to kill fading, fading...

HOMER (CONT'D)

Fading...

(SUDDENLY INTENSE) Rising!

TRANS.

HOMER DROPS AXE, GRABS TV; SITS DOWN IN SNOW

Homer freezes in his tracks.

HOMER

(GASP) Television! Teacher, mother, secret lover.

HOMER (CONT'D)

(CALM AGAIN) ...Fading,

NOTES

FILM ROMAN

THE SIMPSONS

TITLE _____

SHOW 2FD3

ACT I

PAGE 65

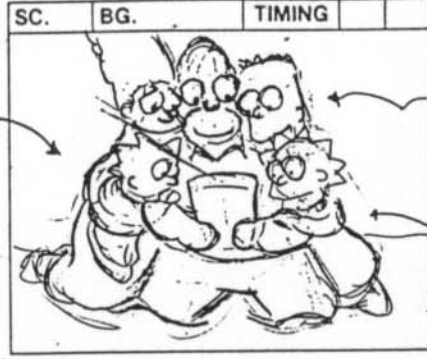
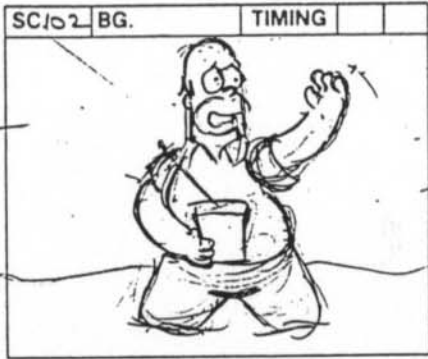

MATCH CUT

ACTION

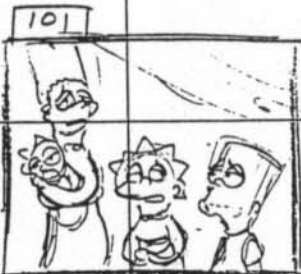

HOMER BECKONS TO FAMILY

FAMILY SITS DOWN NEXT TO HOMER

MATCH CUT TO FAMILY

FROZEN SOLID

cut closer

The family sits around Homer. They all watch TV.

TRANS.

HOMER SLUMPS DOWN

EXT. RETREAT

The Simpsons are frozen solid in the same position in front of the TV set.

KUBRICK MATCH CUT:

only slight lip movements

DIAL

fading, gone.

The family SIGHS.

HOMER (CONT'D)

Come, family, sit in the snow with Daddy and let us all bask in television's warm glowing, warming glow.

sits down

ANNOUNCER (V.O.)

And now, live from Broadway, it's the Tony Awards! (MUSIC BEGINS) With your hosts, Tye Daly and Hal Linden.

TRANS.

BART

(FROZEN MOUTH) Homer, change channel!

HOMER

Can't. Frozen.

NOTES

CHORUS (V.O.)

(SINGING) "One!..."

FILM ROMAN

THE SIMPSONS

TITLE _____ SHOW 2FD3 ACT I PAGE 66

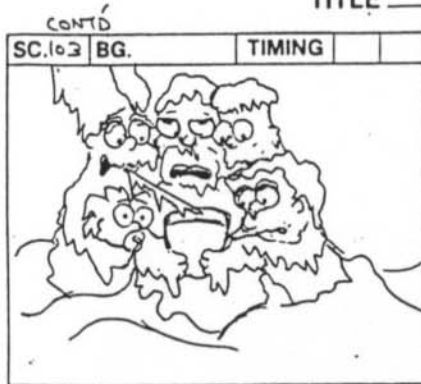

SC.	BG.	TIMING
<p>END OF ACT I</p>		

SC.	BG.	TIMING

SC.	BG.	TIMING

ACTION

TRANS.

DIAL

TRANS.

NOTES

<p>FAMILY</p> <p>(SCREAM)</p> <p>CHORUS (V.O.)</p> <p>(SINGING) "singular sensation..."</p>			
<p>HOMER</p> <p>Urge to kill rising.</p>			
	FADE OUT:		
	THE END		

THE SIMPSONS

EPISODE #	2F03
EPISODE TITLE	"TREEHOUSE OF HORROR V"
ACT II	
ROUGH DRAFT	5/6/94
REVISED	5/24/94
FINAL	

FILM ROMAN

THE SIMPSONS

TITLE "TREEHOUSE OF HORROR V"

SHOW 2F03

ACT II

PAGE 67

SC.	BG.	TIMING
<p>THE SIMPSONS TREEHOUSE OF HORROR PART V ACT II</p>		

SC.	BG.	TIMING	SC.104	BG.	TIMING
<p><u>TIME AND PUNISHMENT</u> by Greg Daniels and Dan McGrath</p>					

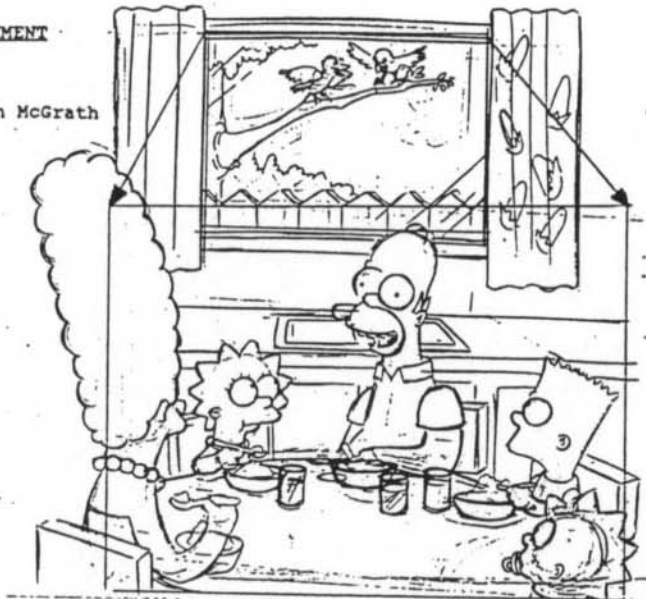
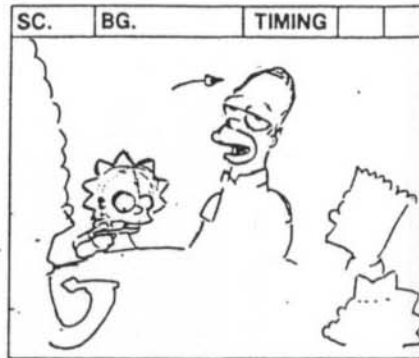

ACTION

STORYBOARD BY
 STEVEN DEAN MOORE
 ASSISTED BY JOHN MATHOT

TRANS.

DIAL

HOMER

Y'know, Marge, I've had my share of
 troubles

TRANS.

NOTES

FILM ROMAN

THE SIMPSONS

TITLE _____

SHOW 2F03

ACT II

PAGE 108

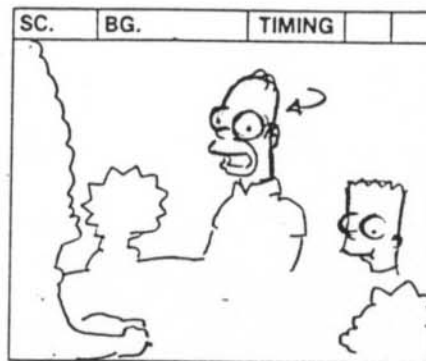
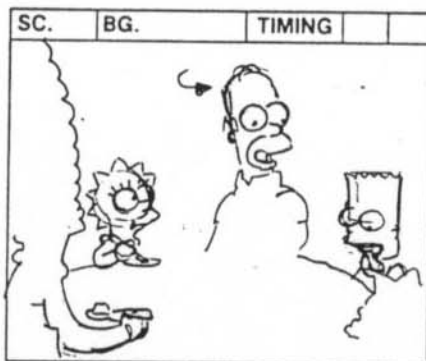
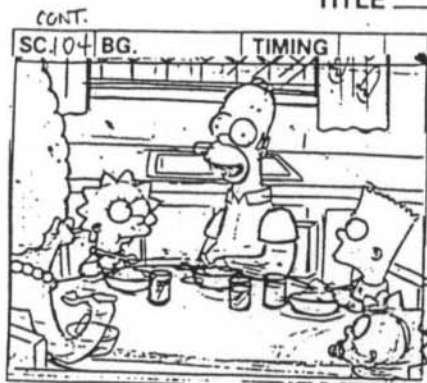

ACTION

TRANS.

DIAL

TRANS.

NOTES

but sitting here now with you
and the kids, in our cozy home in this
beautiful, free country,

it just makes
me feel that I'm really a lucky guy.

LISA
(EXTREMELY ALARMED) Dad!! Your hand
is jammed in the toaster!!

FILM ROMAN

THE SIMPSONS

TITLE _____

SHOW ZF03

ACT II

PAGE 69

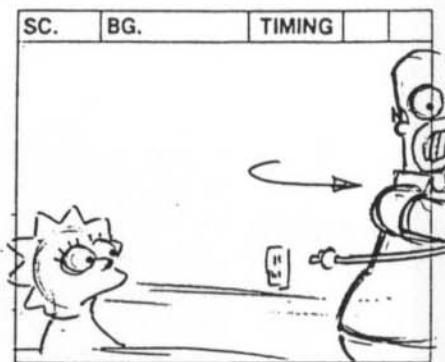
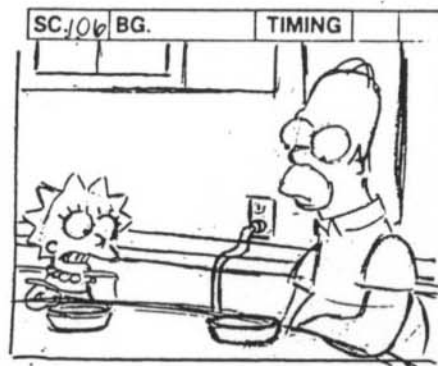

ACTIO

JUMP BACK TO REVEAL

Homer's hand is stuck in the SPARKING, smoking toaster.
Realizing, he leaps up, wrenches it from the wall socket

TRANS.

DIAL

TRANS.

NOTES

HOMER

Yllahl!! Get it off!

FILM ROMAN

THE SIMPSONS

TITLE _____ SHOW 2F03 ACT II PAGE 70

§ SC107

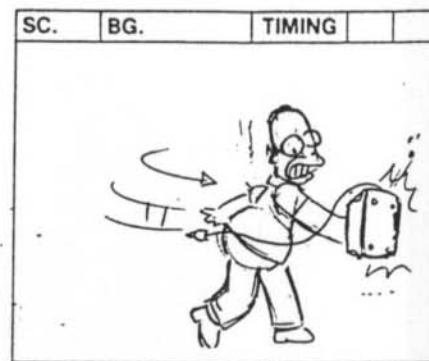
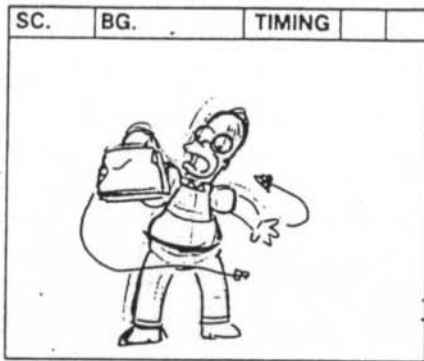
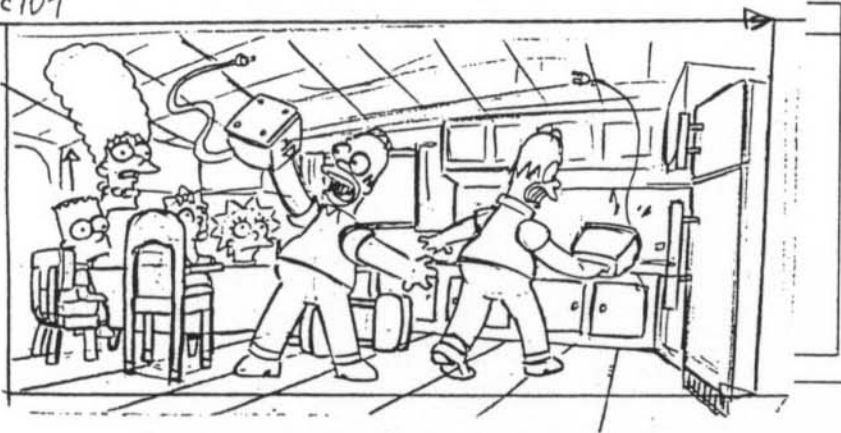

ACTION

and BANGS it against the wall, WEIMPERING and SCREAMING.

TRANS.

DIAL

BART / LISA / MARGE
 (WILD YOWLS) Dad!! Daaadd!! Homer!!

Get it off! Get it off!!

TRANS.

NOTES

FILM ROMAN

THE SIMPSONS

TITLE _____

SHOW 2FO3

ACT II

PAGE 71

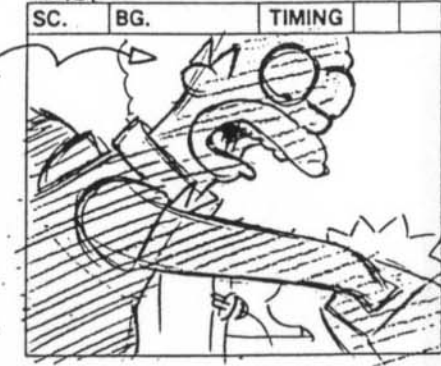
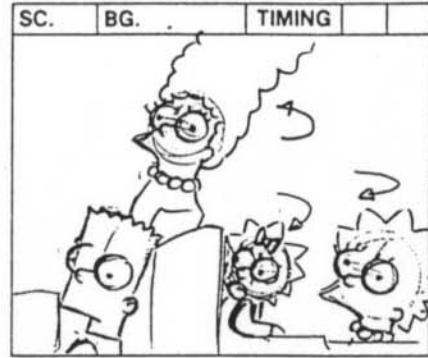
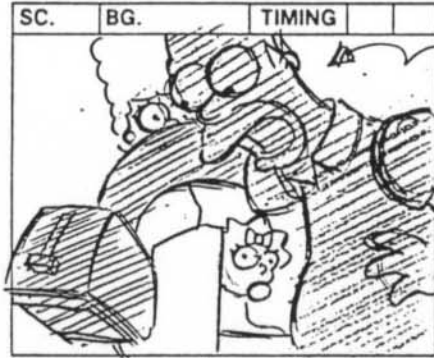
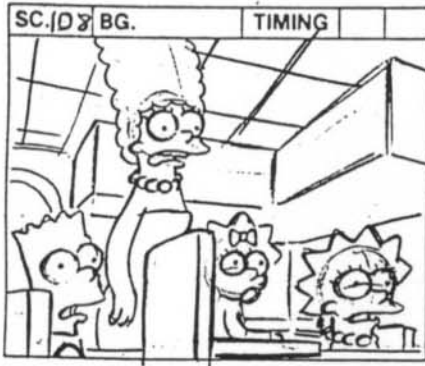

ACTION

TRANS.

DIAL

TRANS.

NOTES

<p><u>HOMER</u> SCREAMING MARE/KIDS (CONT) (?)</p>			

FILM ROMAN

THE SIMPSONS

TITLE _____

SHOW 2503

ACT II

PAGE 72

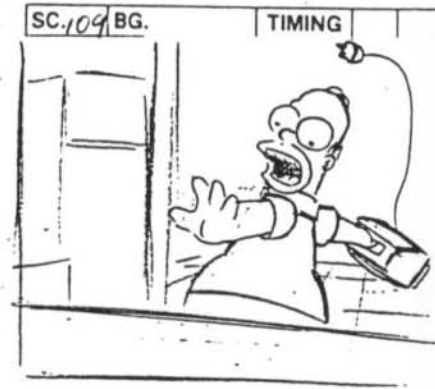
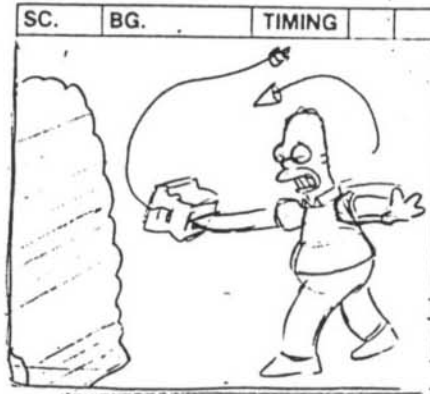
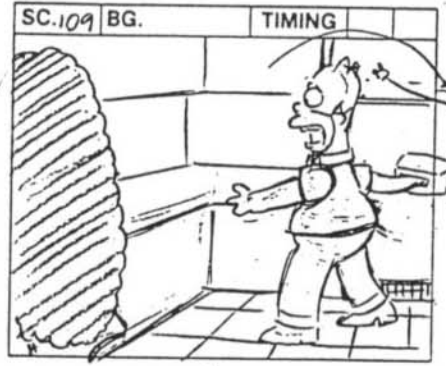
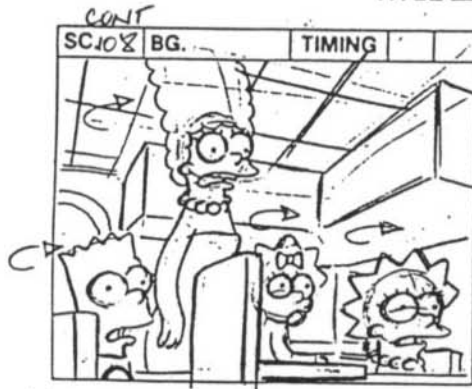

ACTION

TRANS.

DIAL

TRANS.

NOTES

HOMER (CONT)
SCREAMING



FILM ROMAN

THE SIMPSONS

CONT.

TITLE _____

SHOW 2F03

ACT II

PAGE 73

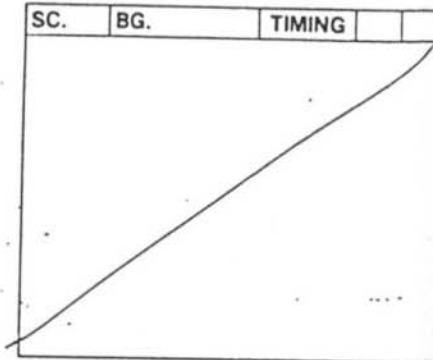
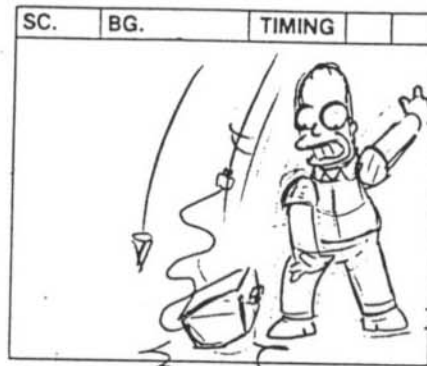
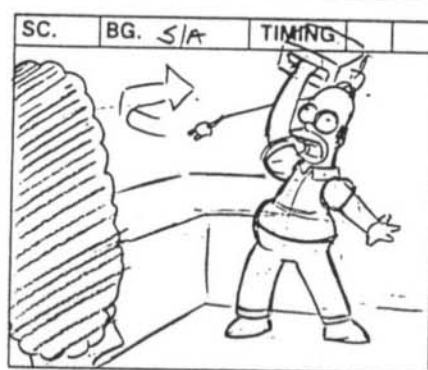

ACTION

Finally the toaster shakes loose from his hand and HITS the floor.

TRANS.

DIAL

TRANS.

NOTES

FILM ROMAN

THE SIMPSONS

TITLE _____

SHOW 2F03

ACT II

PAGE 74

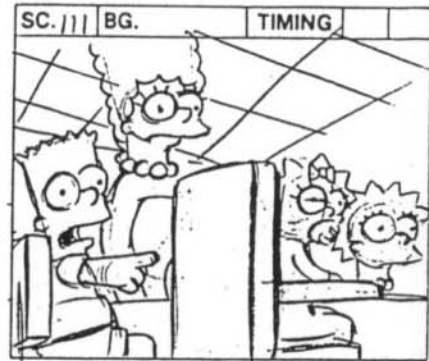
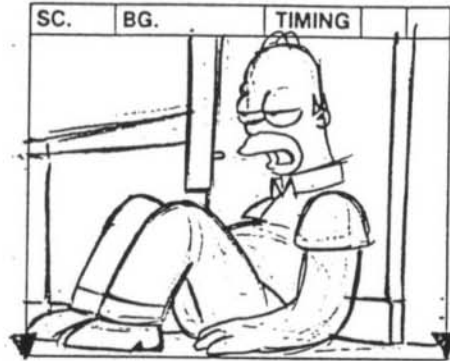
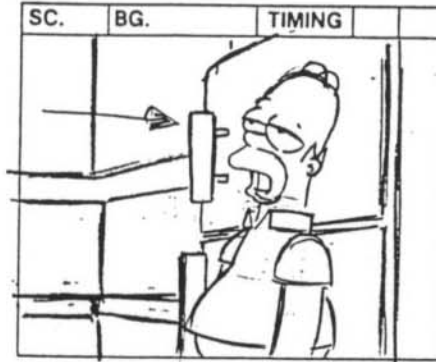

ACTIC

Homer sags against the ~~door~~, GASPING, and sits down.
REFRIGERATOR

TRANS.

DIAL

HOMER (CONT'D)
(PROLONGED EXHAUSTED BREATHING,
FOLLOWED BY A RELIEVED SIGH)

TRANS.

BART
Dad, it's in there again!

NOTES

FILM ROMAN

THE SIMPSONS

TITLE _____

SHOW 2F03

ACT II

PAGE 75

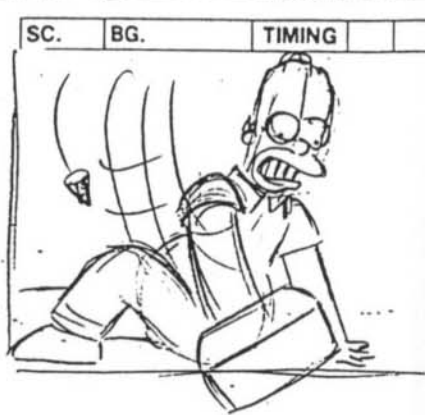
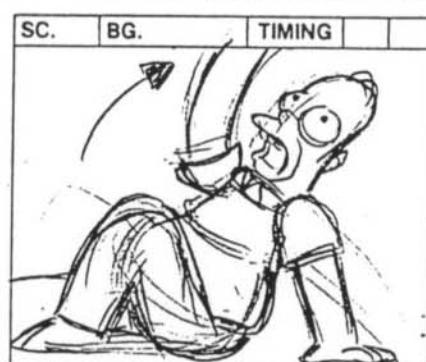
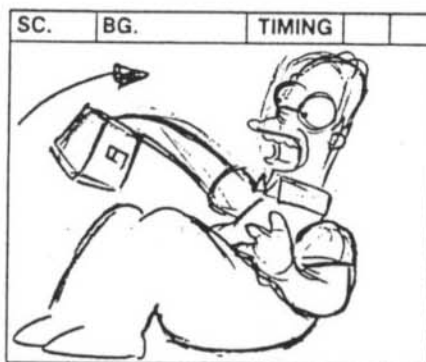
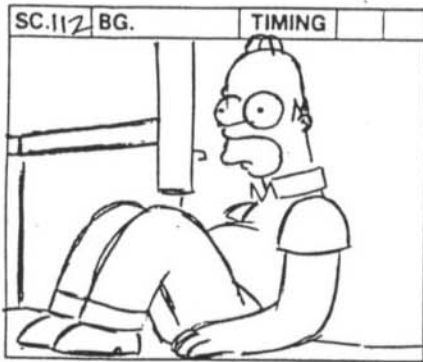

ACTION

We see the toaster on Homer's hand. He begins SCREAMING again.

TRANS.

DIAL

TRANS.

NOTES

FILM ROMAN

THE SIMPSONS

TITLE _____ SHOW 2F03 ACT II PAGE 70

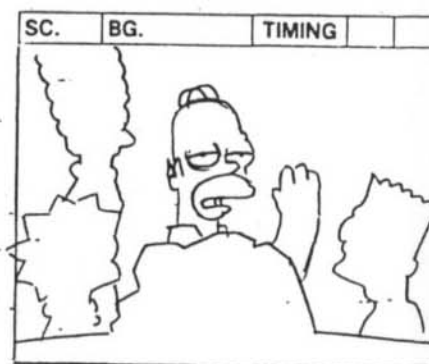
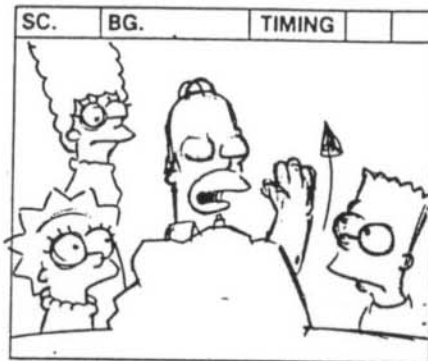
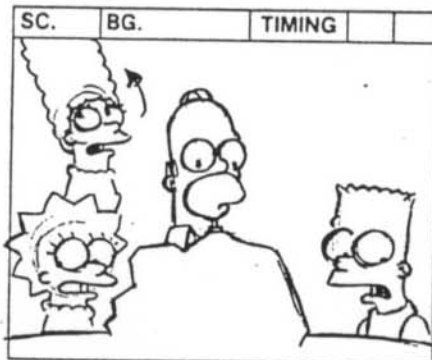
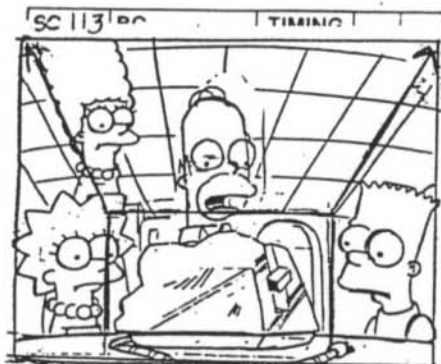

ACTION

INT. SIMPSON KITCHEN - LATER

The family sit looking at the cracked, banged-up toaster.

TRANS.

DIAL

HOMER

(QUIETLY) This is my fault.

MARGE / BART / LISA

(HALF-HEARTED) No, no. Really, no. Not at all.

HOMER

Yes it is; I won't hear otherwise.

TRANS.

NOTES

FILM ROMAN

THE SIMPSONS

SHOW 203 ACT II PAGE 77

TITLE _____

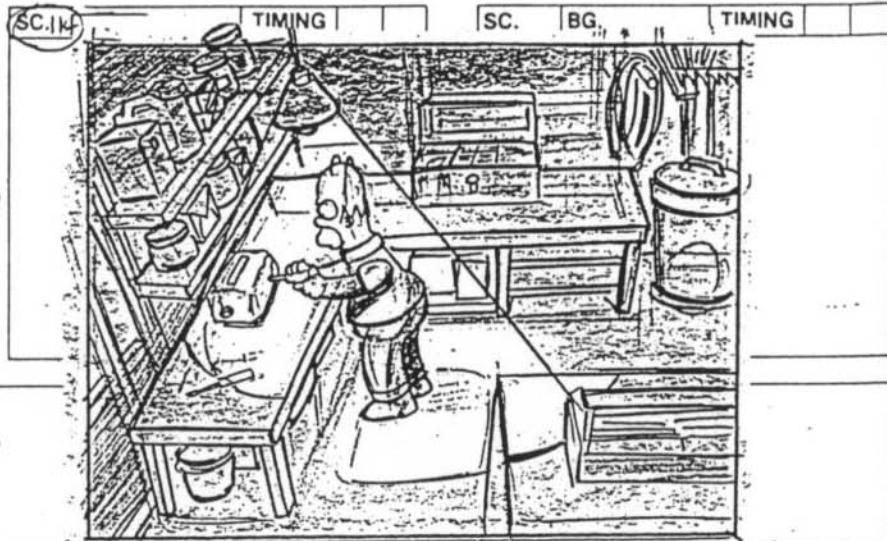
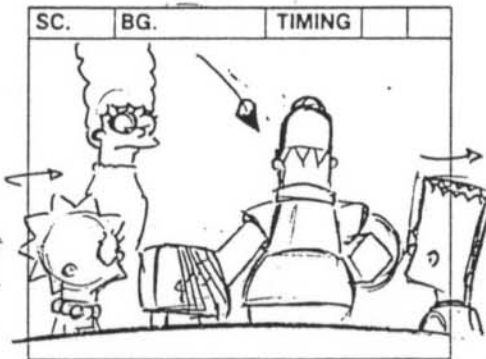
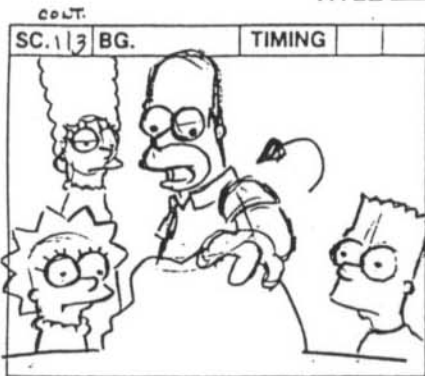

ACTION

Homer gets up to leave. We see his hand is clumsily bandaged to a chair which drags behind him.

TRANS.

INT. BASEMENT - A LITTLE LATER

DIAL

I'm

going to fix this thing myself, just like I bandaged my own hand.

TRANS.

NOTES

FILM ROMAN

THE SIMPSONS

TITLE _____

SHOW 2F03

ACT II

PAGE 78

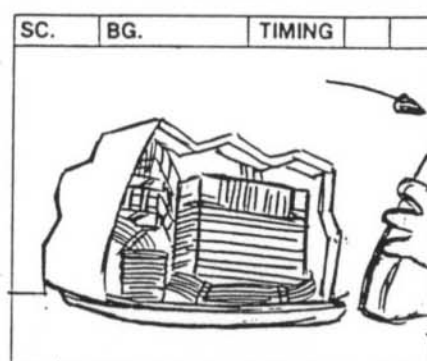
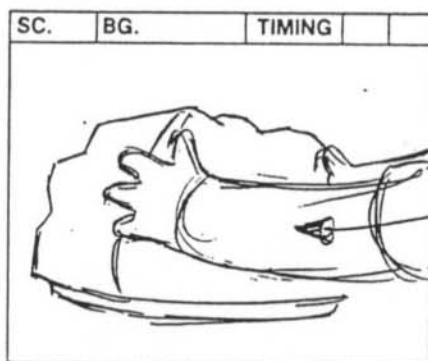
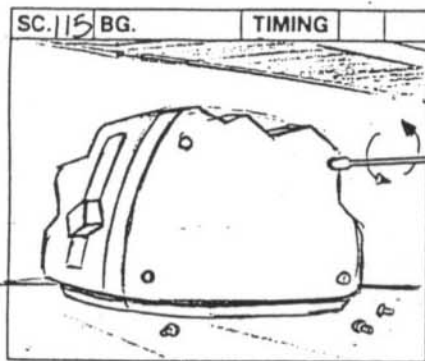

ACTION

Homer has just snapped off the back of the broken toaster. Inside is a HUMMING, glistening complex of circuitry, diodes, and multi-colored wires.

TO BE ~~DESIGNED~~
DESIGNED

HOMER LOOKS AT
THE TOASTER.
(A BEAT)

TRANS.

DIAL

TRANS.

NOTES

FILM ROMAN

THE SIMPSONS

CONT.

TITLE _____

SHOW 2F03

ACT II

PAGE 79

SC. 116 BG.

TIMING

IG

SC.

BG.

TIMING

SC.

BG.

TIMING



TOOL + WORK
SFX AS WE
PAN OFF HOMER?



ACTION

TRANS.

HE PICKS A
HAMER AND
SMILES - WE PAN
UP TO BASEMENT
WINDOW

INT. BASEMENT - SUNRISE

Finished!
The toaster is now repaired, but has many extra clumps of
circuits and glowing tubes attached. Homer looks at all
the tools, machinery, blackboards, etc.:

HOMER

ENT-BASEMENT WINDOW
DISS TO DAWN
D PAN TO HOMER

DIAL

SC. 116 BG.

TIMING

TRANS.

SC. 116A
PICK-UP
NEW TOASTER
TO BE DESIGNED

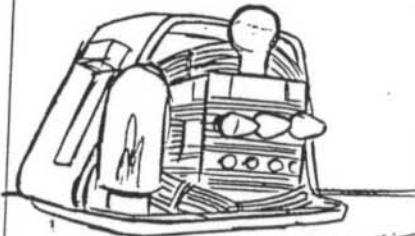

NOTES

FILM ROMAN

THE SIMPSONS

NO PAGE 80

TITLE _____

SHOW ZFO3

ACT II

PAGE 81

CONT

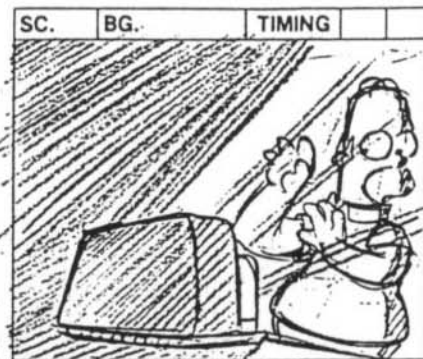
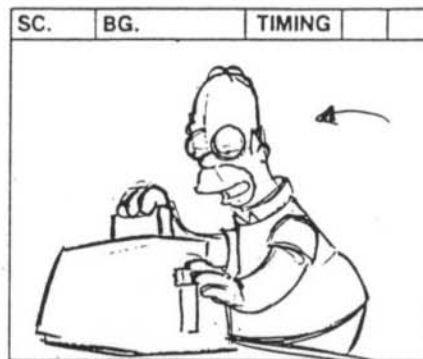
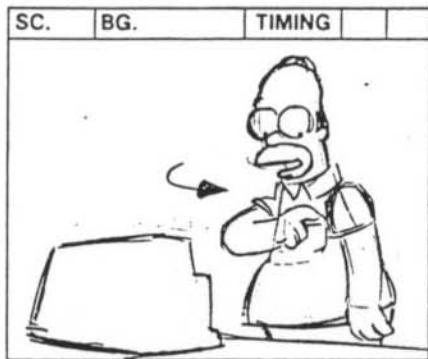
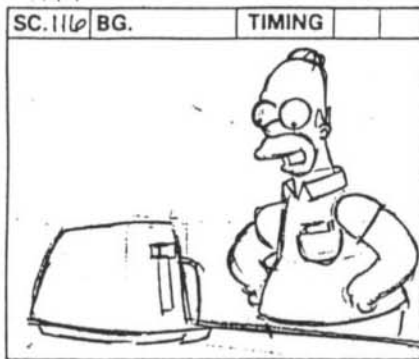

ACTION

He puts in some bread. The toaster begins to shiver and make a MENACING NOISE. We see a BLINDING ARC OF LIGHT.

BREAD SLICE IN POCKET

TRANS.

Lose cord



HOMER
What the-?

DIAL

Now to take her for a test

toast.

TRANS.

NOTES

FILM ROMAN

THE SIMPSONS

TITLE _____ SHOW 2603 ACT II PAGE 82

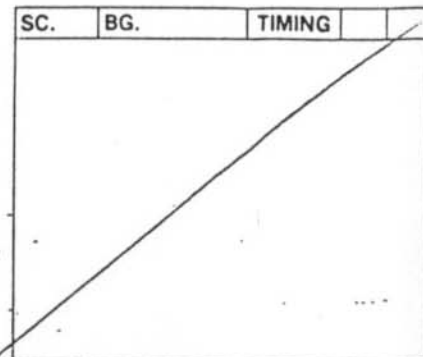
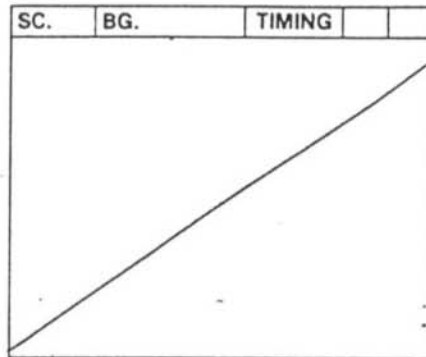
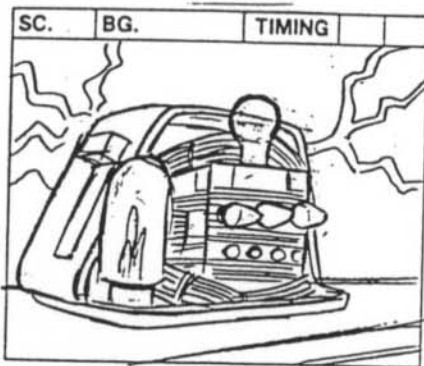
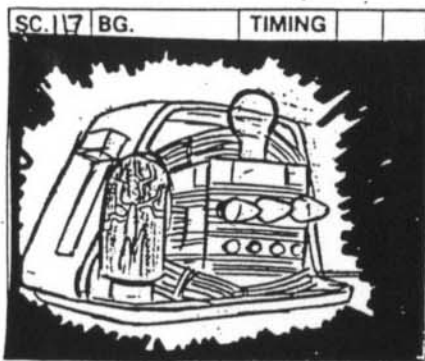

ACTION	ON TOASTER EMITTING VARIOUS LIGHT FX, TO BE DESIGNED		
TRANS.			
DIAL			
TRANS.			
NOTES			

FILM ROMAN

THE SIMPSONS

TITLE _____

SHOW 2F03

ACT II

PAGE 83

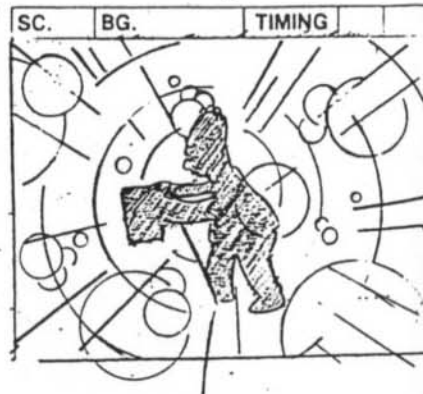
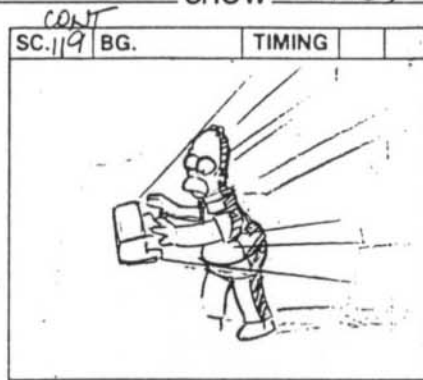
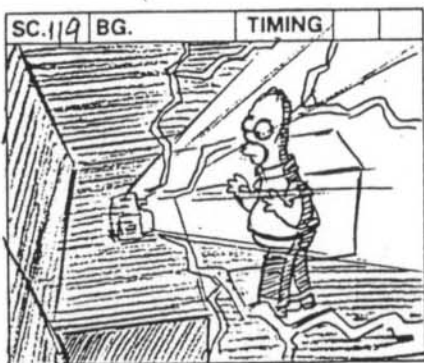
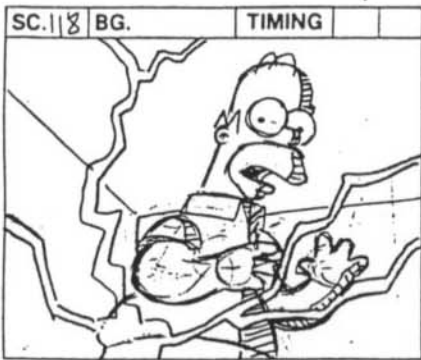

ACTION

PICK UP HOMER

THESE FX ARE QUICK-

TRANS.

DIAL

TRANS.

NOTES

FILM ROMAN

THE SIMPSONS

TITLE _____

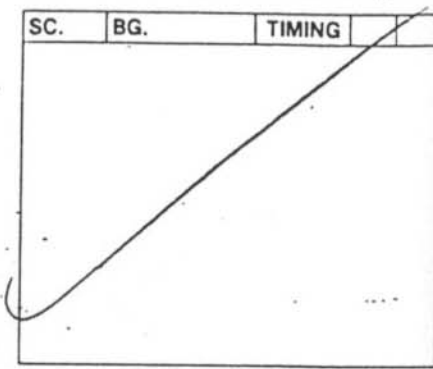
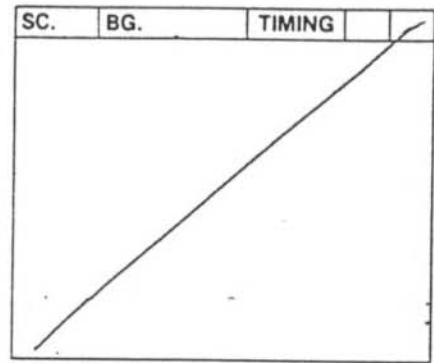
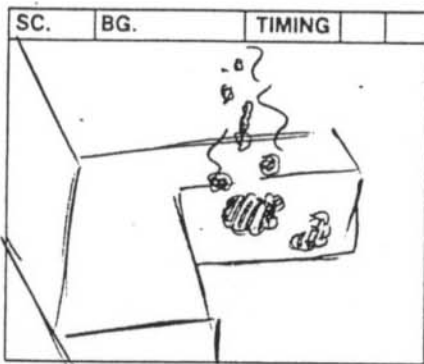
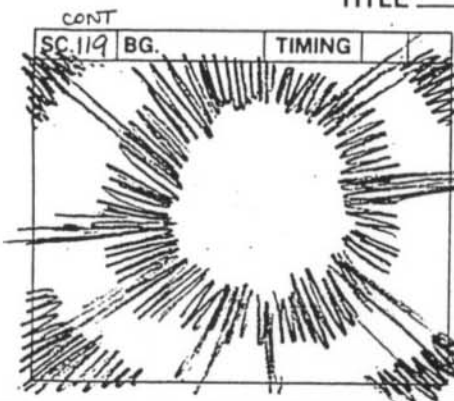
SHOW 2F03ACT IIPAGE 84

ACTION

Homer and the toaster are gone in a wisp of smoke.

TRANS.

DIAL

TRANS.

NOTES

SC 120

85

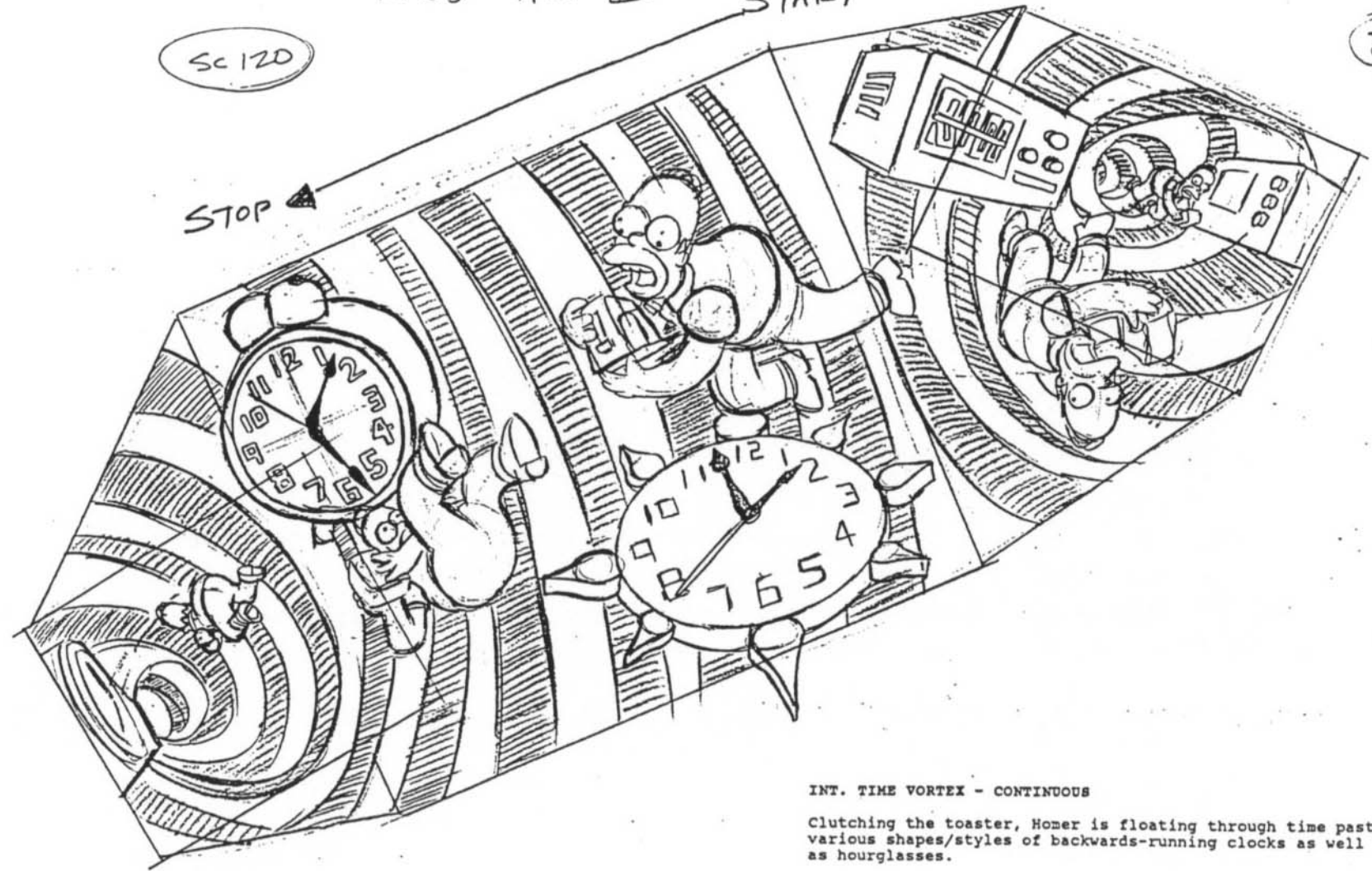

INT. TIME VORTEX - CONTINUOUS

Clutching the toaster, Homer is floating through time past various shapes/styles of backwards-running clocks as well as hourglasses.

FILM ROMAN

THE SIMPSONS

TITLE _____

SHOW 2F03

ACT II

PAGE 86

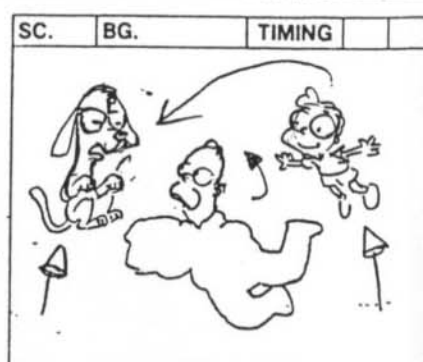
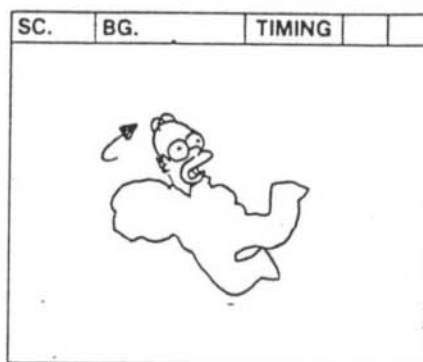
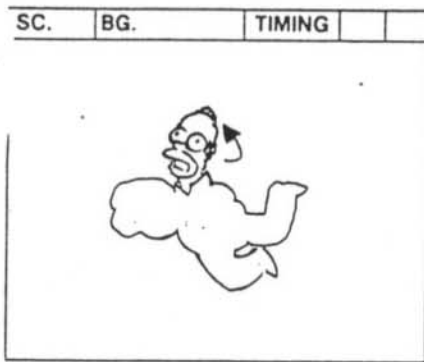
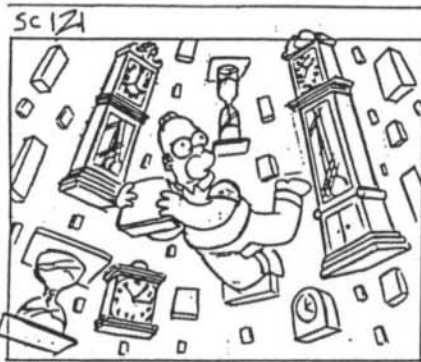

ACTION

MR. PEABODY and SHERMAN come floating by Homer.

TRANS.

P + S on same side

DIAL

HOMER
(RE: CLOCKS) Look at that!

(REALIZATION) I'm the first non-
fictional character to travel backwards
through time!

MR. PEABODY
Correction, Homer, you're the second.

TRANS.

NOTES

FILM ROMAN

THE SIMPSONS

TITLE _____

SHOW 2F03

ACT II

PAGE 87

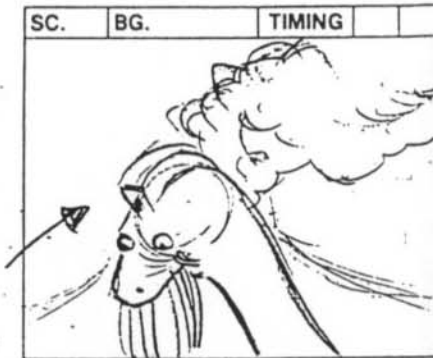
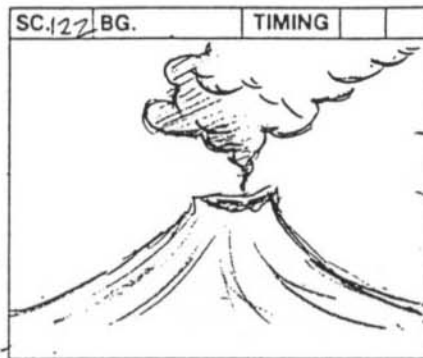
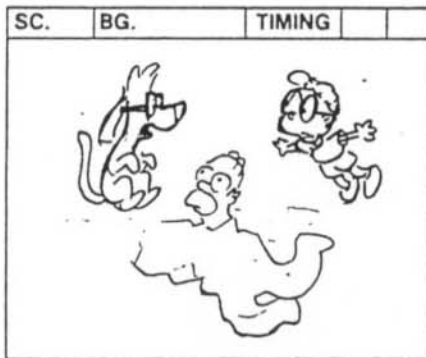
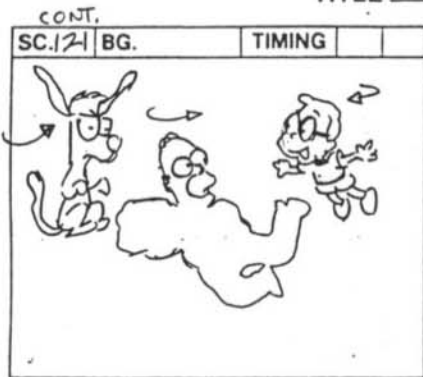

ACTION

ears down

ON VOLCANO

A BRACHIOSAURUS.
RISES UP INTO SC.
CHEWING ON SOME
VEGETATION

TRANS.

DIAL

SHERMAN
That's right, Mr. Peabody.

MR. PEABODY
Quiet, you.

TRANS.

NOTES

CONT
SC122

START

Z1F03

II

88

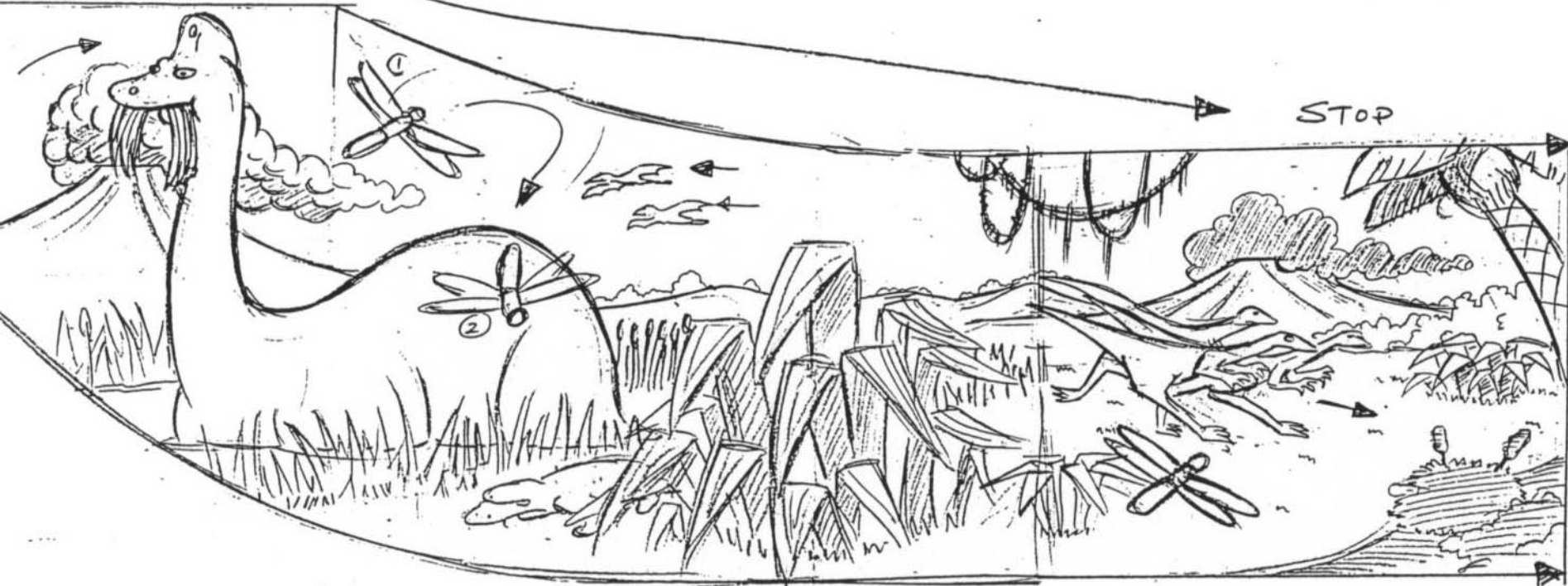

EXT. SPRINGFIELD JUNGLE - 100 MILLION B.C.

In a prehistoric jungle, weird lizards run under giant fern fronds. We hear eerie CHIRPING of Paleozoic insects.

FILM ROMAN

THE SIMPSONS

TITLE _____ SHOW 2F03 ACT II PAGE 89

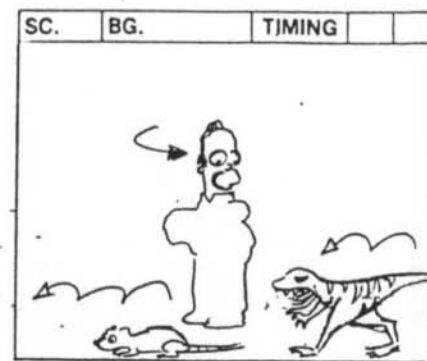
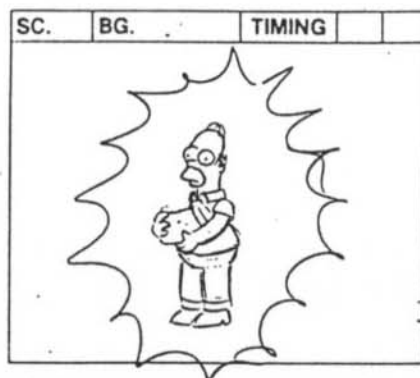
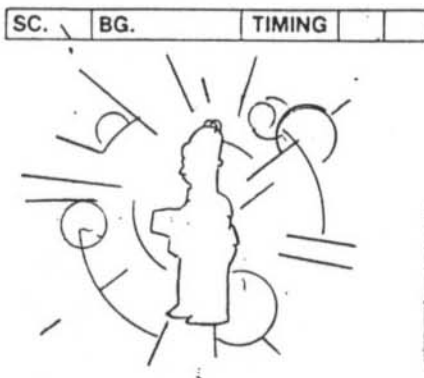
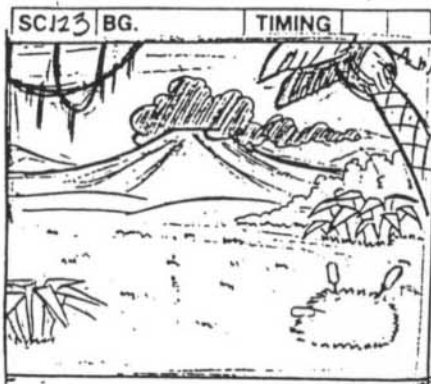

ACTION

HOLD ON BG

FOUR BEAT

Homer appears in a BURST of light, clutching the toaster.

A SMALL DINO
CHASES A SMALL
MAMMAL THRU SC.

TRANS.

DIAL

TRANS.

NOTES

FILM ROMAN

THE SIMPSONS

TITLE _____

SHOW 2F03

ACT II

PAGE 90

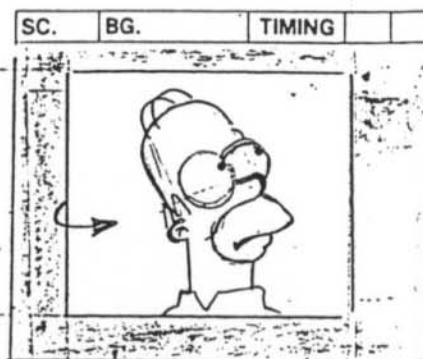
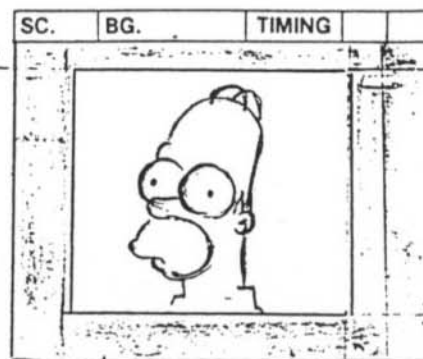
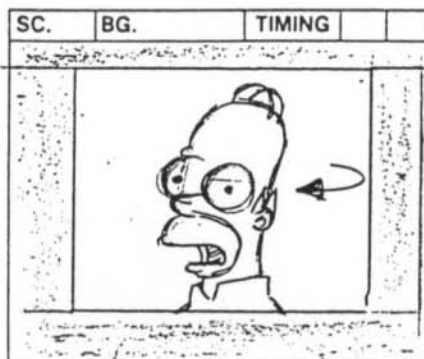
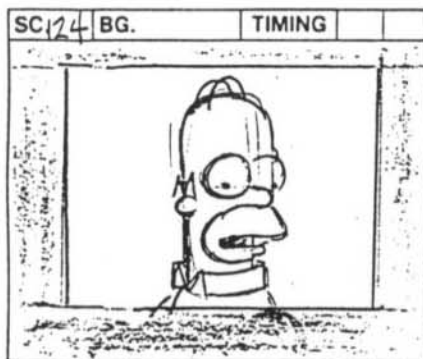

ACTION

HOMER LOOKS UP

TRANS.

DIAL

TRANS.

NOTES

Over pan

HOMER

(AWED) I've gone back to the time when
dinosaurs weren't just confined to
zoos.

v/o

PTERA DACTYL SCREECH

line sc. 122

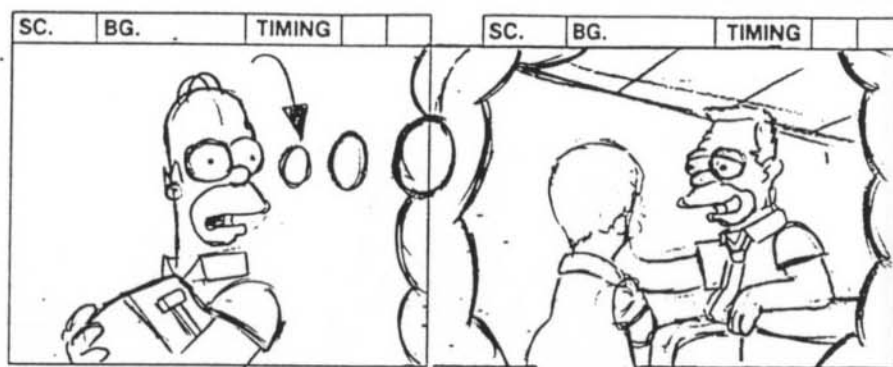
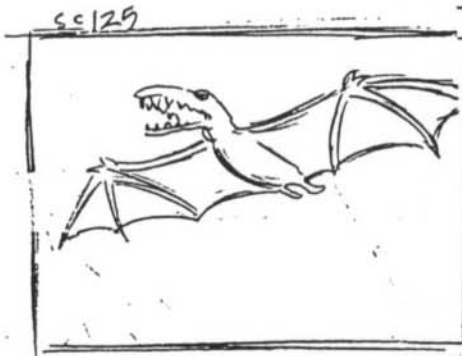

ACTION

Homer sees a pterodactyl fly and SCREECH overhead.

HOMER'S THOUGHT BUBBLE
GRAMPA is lecturing a ten-year-old Homer.

*Tight on
Grampa*

TRANS.

when

DIAL

HOMER (CONT'D)

GRAMPA

OK. Don't panic. Remember
what your father always taught you...

Never eat rice.

TRANS.

NOTES

FILM ROMAN

THE SIMPSONS

TITLE _____

SHOW 2F03

ACT II

PAGE 92

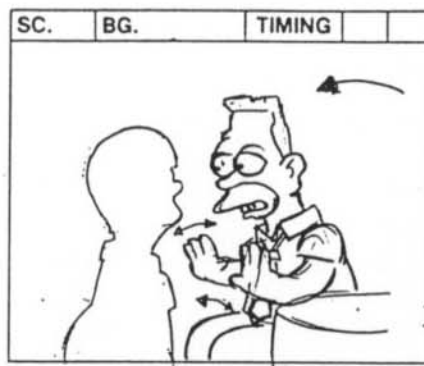
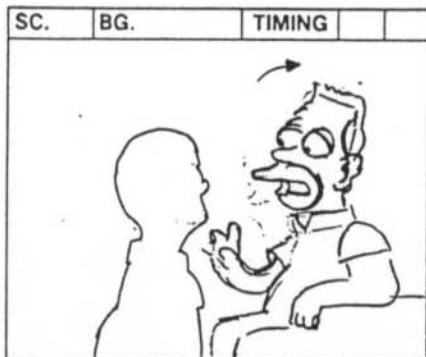

ACTION

SLOW CONTINUOUS

TRUCK IN TO ONE

SHOT OF GRANDPA

TRUCK IN STOPS

TRANS.

DIAL

NEVER... SUN

Never dry a wig in the sun. And if you ever travel back in time,

don't step on anything, because even the tiniest change

TRANS.

NOTES

FILM ROMAN

THE SIMPSONS

TITLE _____

SHOW 2F03

ACT II

PAGE 93

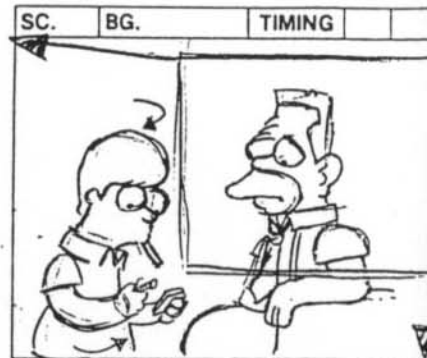
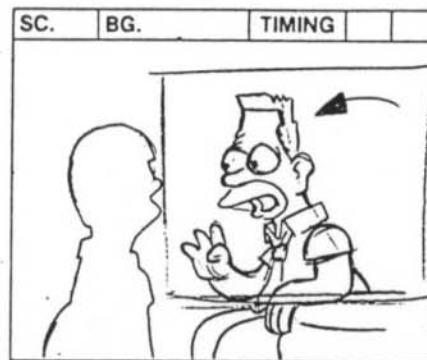
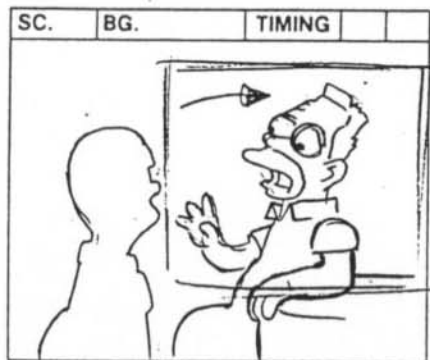

ACTION



HOMER TURNS

We reveal that Homer's been trying to light a cigarette.

TRANS.

DIAL

can create a
domino effect that will alter the
future in ways you can't even imagine.

Remember these three things and nothing
will ever harm you. (BEAT; THEN)

TRANS.

NOTES

FILM ROMAN

THE SIMPSONS

TITLE _____

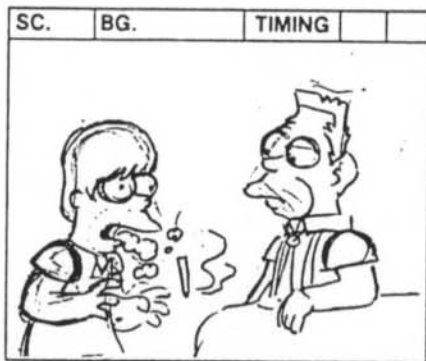
SHOW ZF03ACT #PAGE 94

ACTION

Grampa pulls out a lighter and lights it for him. Homer begins to COUGH. Grampa hands him a shot glass.

TRANS.

DIAL

oh
here, let me help you with that.

TRANS.

*Then
reveal
cigs &
Homer*

NOTES

FILM ROMAN

THE SIMPSONS

TITLE _____ SHOW 2E03 ACT II PAGE 95

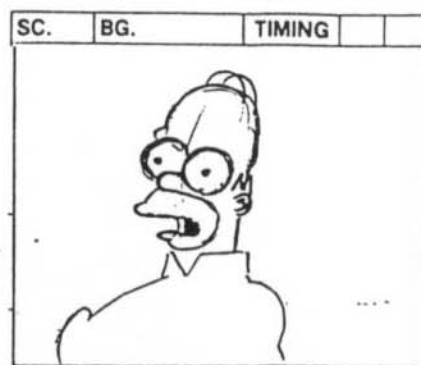
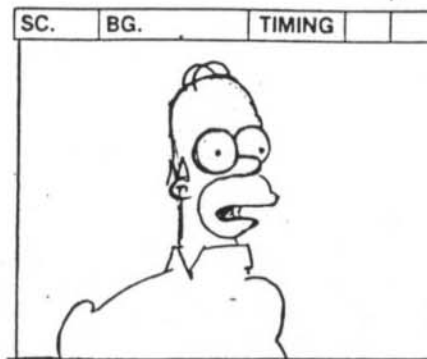

ACTION

BACK ON HOMER

who stands still, clutching the toaster.

TRANS.

DIAL

HOMER

Fine. As long as I stand perfectly
still

TRANS.

NOTES

FILM ROMAN

THE SIMPSONS

CONT.

TITLE _____

SHOW 2FD3

ACT II

PAGE 96

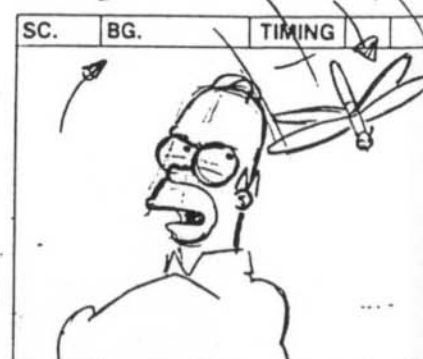
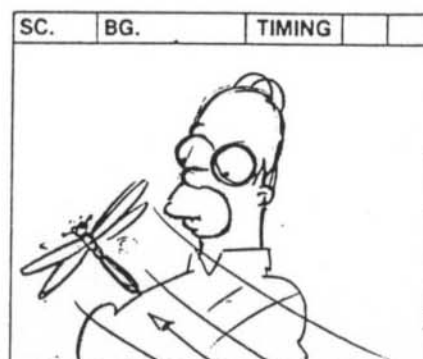
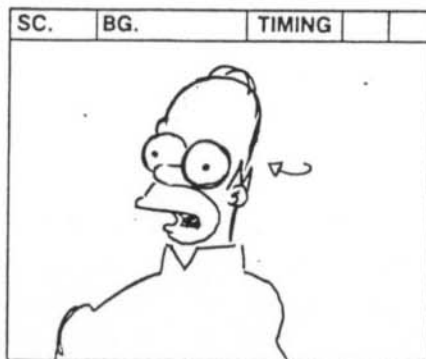
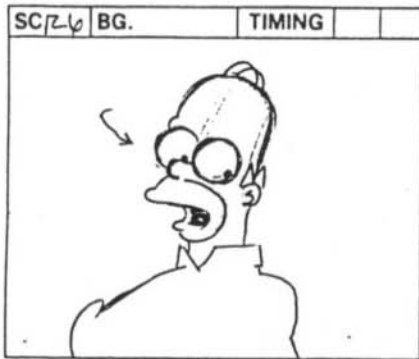

ACTION



HOMER'S EYES FOLLOW DRAGONFLIES' ACTION

HOMER'S EYES FOLLOW ACTION

TRANS.

There is a four-inch prehistoric mosquito BUZZING around his face.

DIAL

and don't touch anything, I won't destroy the future.

HOMER (CONT'D)

Stupid bug.

TRANS.

NOTES

FILM ROMAN

THE SIMPSONS

TITLE _____

SHOW 2F03

ACT II

PAGE 97

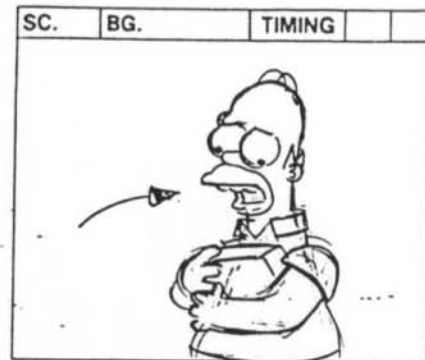
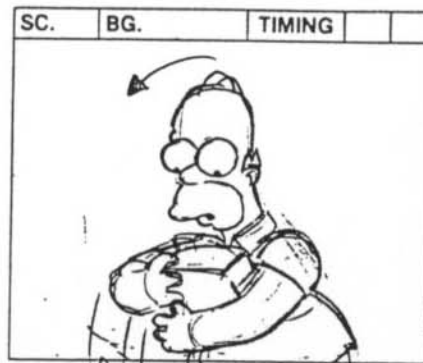
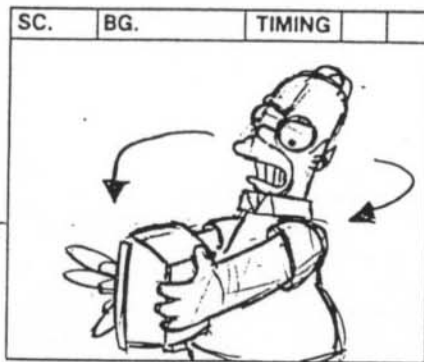
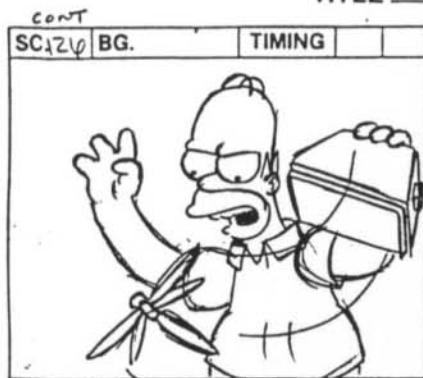

ACTION

He thoughtlessly SWATS the mosquito and kills it.

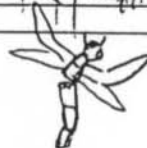

TRANS.

DIAL

You go squish now...

HOMER (CONT'D)

(BEAT. REALIZING) (GASP) But that was just one little insignificant mosquito.

TRANS.

NOTES

FILM ROMAN

THE SIMPSONS

TITLE _____

SHOW 2FD3

ACT II

PAGE 98

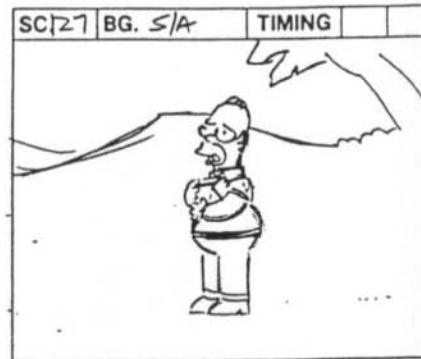
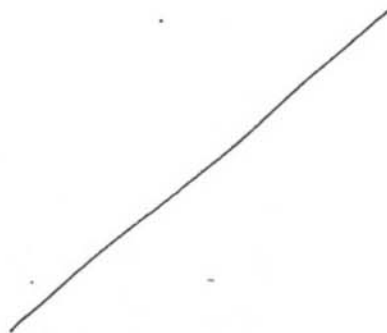
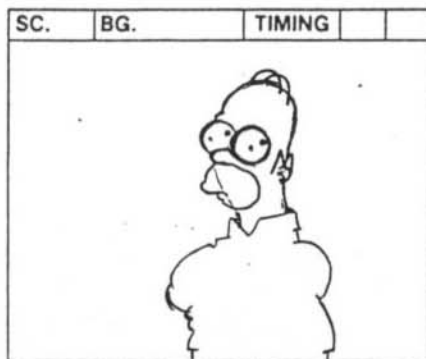

ACTION

TRANS.

DIAL

That can't change the future, right?

Right?

TRANS.

NOTES

FILM ROMAN

THE SIMPSONS

TITLE _____

SHOW 2F03

ACT II

PAGE 99

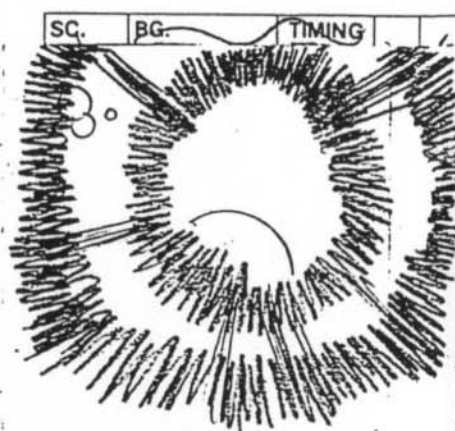
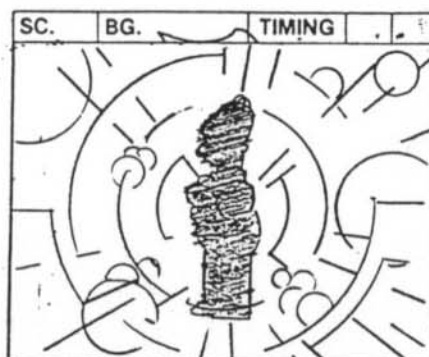
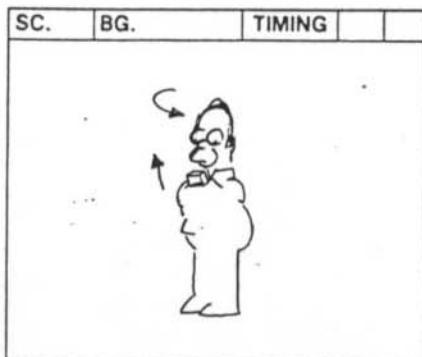
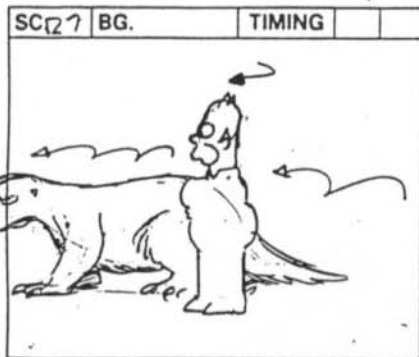

ACTION

A giant prehistoric SLOTH passes by.

In that moment, the toaster POPS up and Homer disappears in a flash of light.

TRANS.

*cut wide w/
sloth in
frame*

*sloth
ixds*

DIAL

SLOTH
(NONCOMMITTAL GRUNT)

TRANS.

NOTES

FILM ROMAN

THE SIMPSONS

TITLE _____

SHOW 2F03 A

II

100

CONT			
SC.	BG.	TIMING	

SC.	BG.	TIMING	
-----	-----	--------	--

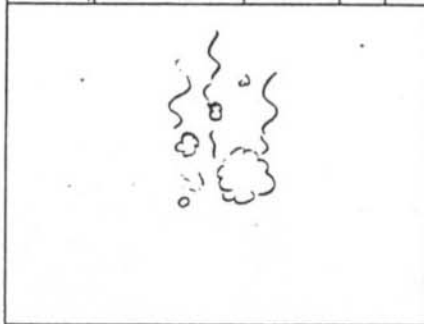

SC.	BG.	TIMING	
-----	-----	--------	--

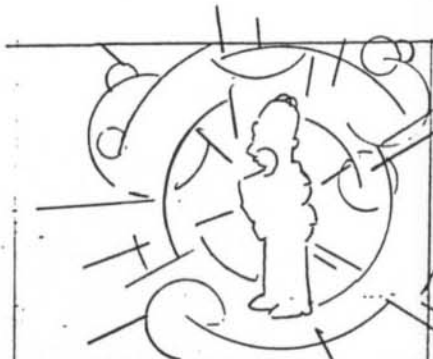
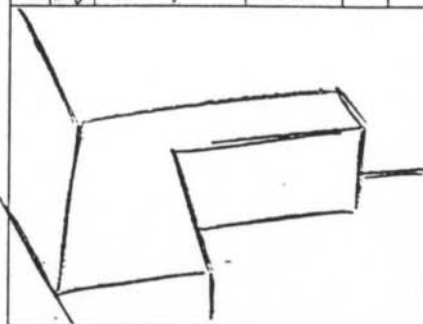

ACTIC

INT. BASEMENT -
HOLD ON BG

TRANS.

INT. BASEMENT - CONTINUOUS

Homer, holding the toaster, appears in another BLINDING FLASH OF LIGHT.

DIAL

TRANS.

NOTES

FILM ROMAN

THE SIMPSONS

TITLE _____

SHOW 2F03

ACT II

PAGE 101

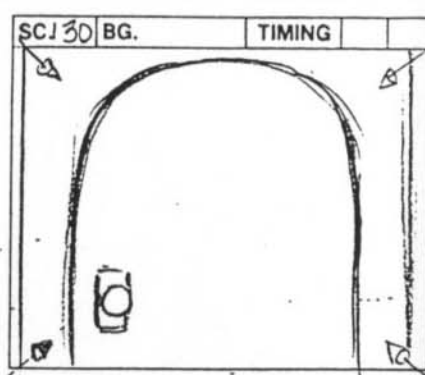
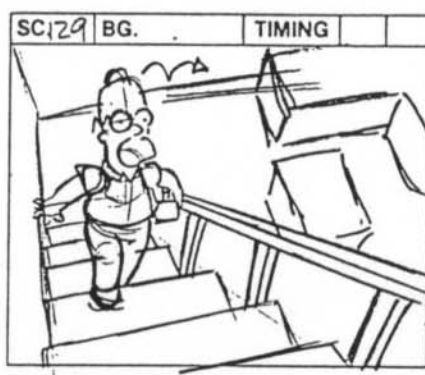
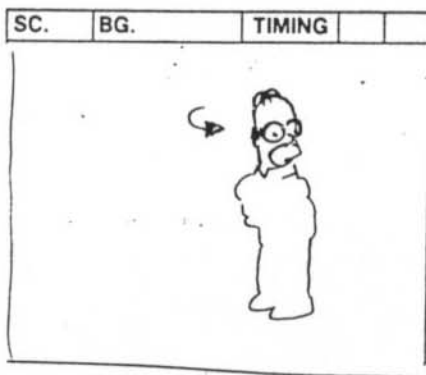
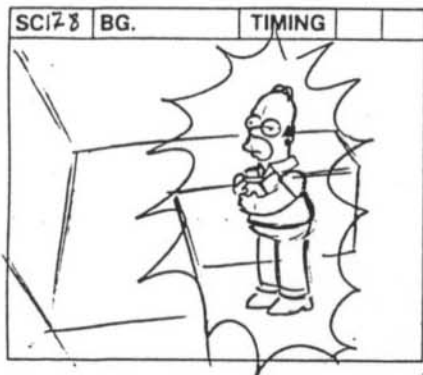

ACTION

HOMER LOOKS
AROUND

HOMER WALKS
UP THE STAIRS

HOMER'S POV
TRUCK IN

(CONT) →

TRANS.

DIAL

TRANS.

NOTES

FILM ROMAN

THE SIMPSONS

TITLE _____

SHOW 2F03

ACT II

PAGE 102

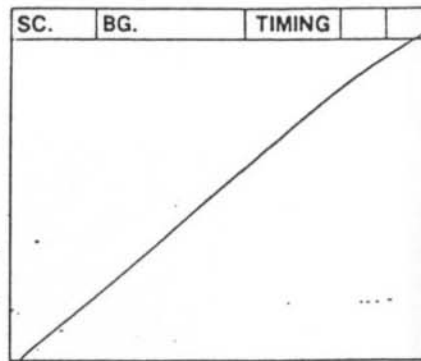
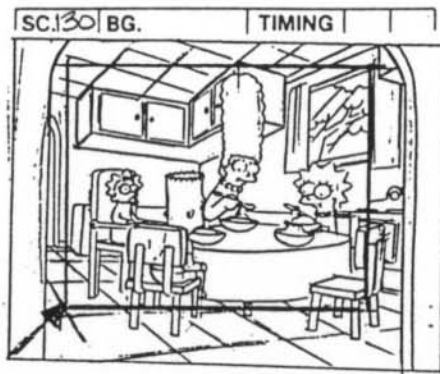
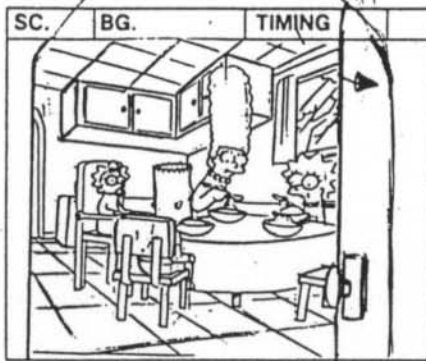
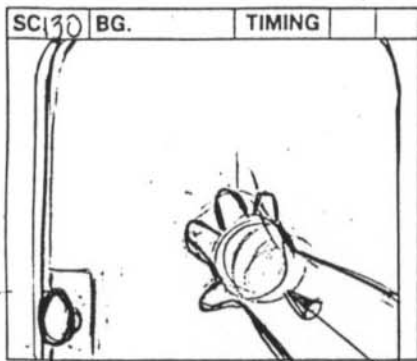

ACTION

INT. KITCHEN

Homer enters from the basement as the family eats breakfast again, as in scene 1. Birds are CHIRPING, all is happy.

→
DOOR
SWINGS O.S

TRANS.

DIAL

TRANS.

NOTES

FILM ROMAN

THE SIMPSONS

TITLE _____

SHOW 2403

ACT II

PAGE 103

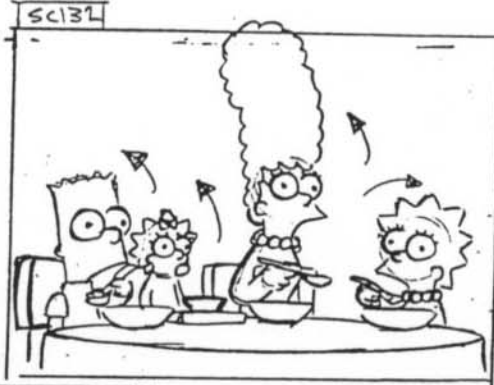
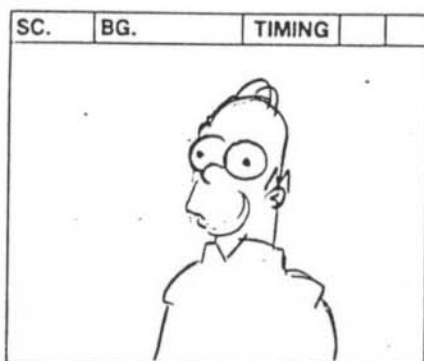

ACTION

TRANS.

DIAL

TRANS.

NOTES

Homer is cut off by a loud, OMINOUS SIREN. The family members instantly go blank

Wide shot

HOMER

Oh, my loving family. Nothing's changed.

FILM ROMAN

THE SIMPSONS

TITLE _____

SHOW 2F03

ACT II

PAGE 104

SC133	BG.	TIMING
-------	-----	--------

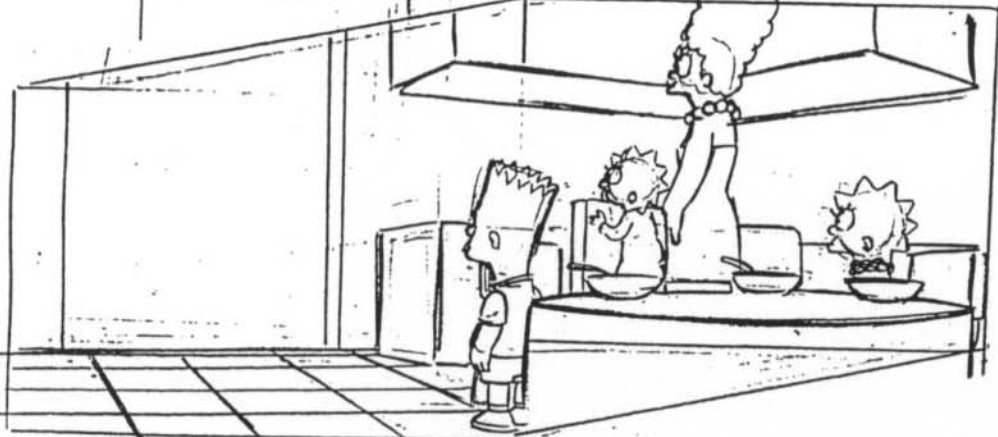

SC134	TIMING
-------	--------

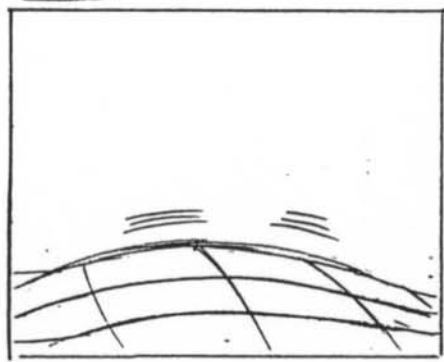

SC.	RG.	TIMING
-----	-----	--------

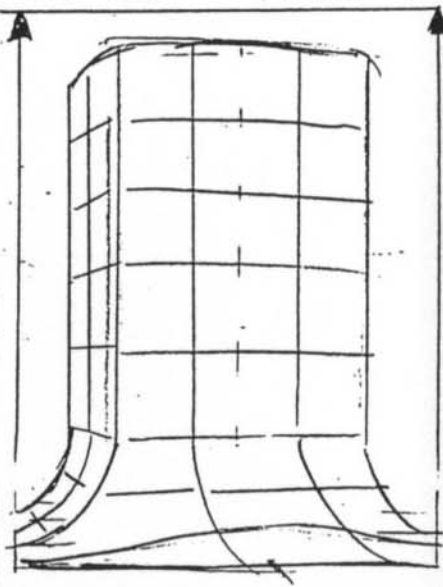

(and mechanically turn their chairs in unison toward a point in the room). The floor liquifies and out rises a monitor (still holding the floor's checkerboard pattern).

TRANS.

DIAL

TRANS.

NOTES

FILM ROMAN

THE SIMPSONS

TITLE _____

SHOW 2F03

ACT II

PAGE 105

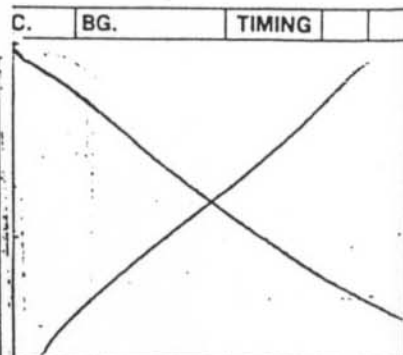
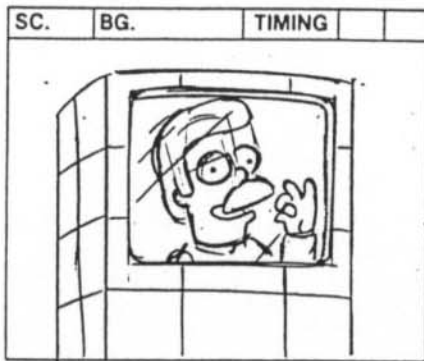
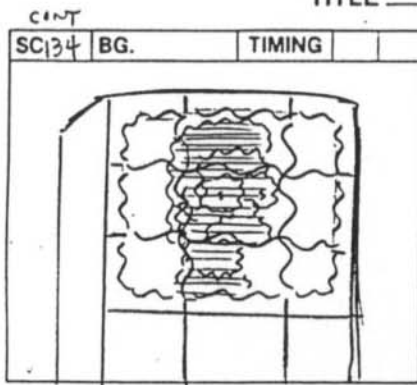

ACTION

FLANDERS appears on the monitor..

The family all raise their hands in salute, giving the OK sign.

TRANS.

DIAL

FLANDERS
Hidilly ho, slave-a-reenos.

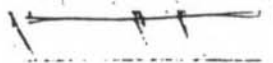

MARGE/BART/LISA

(MECHANICALLY HAPPY) Okilly dokilly.

TRANS.

new 4-shot (tighter) w/
Homer in BG.

NOTES



FILM ROMAN

THE SIMPSONS

TITLE _____

SHOW 2603

ACT II

PAGE 106

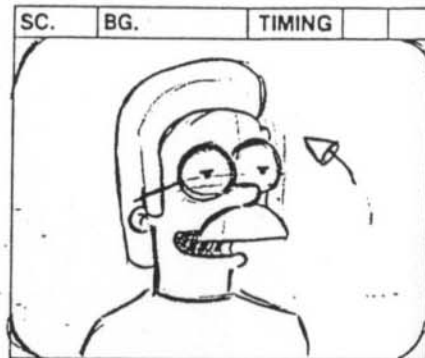
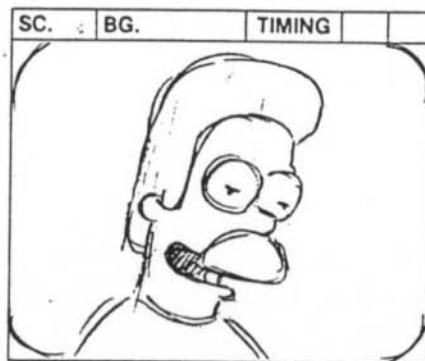
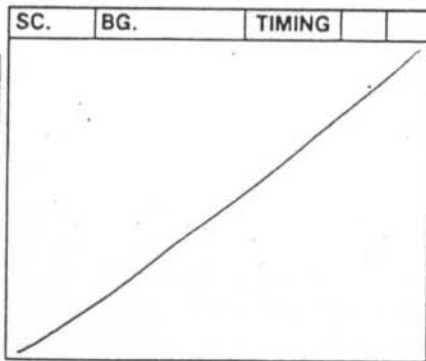

ACTION

TRUCK IN GRADUALLY
PAN OUT FAMILY

TRANS.

DIAL

FLANDERS

Ho ho- sure is a beautiful morn', so
I'd like to ask all of you to increase
your work output just a skosh.

Course,
those of you who resist, well...

TRANS.

NOTES

gesture

FILM ROMAN

THE SIMPSONS

TITLE _____

SHOW 2603

ACT II

PAGE 107

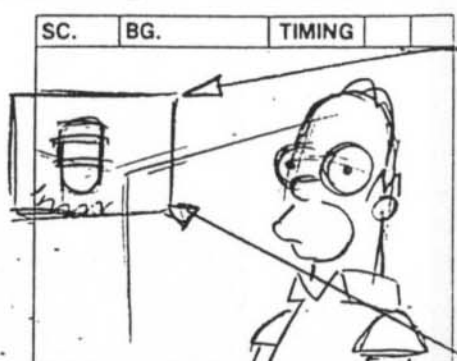
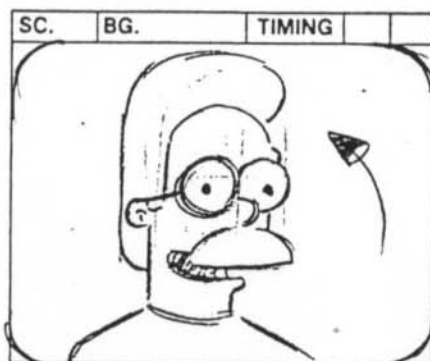

ACTION

"TROMBONE TRUCK IN"

An ALARM goes off. Red lights flash.

TRANS.

CAM. ADJUST ON TRUCK IN
TO REVEAL RED LIGHT
IN BG

(CONT) →

DIAL

Too hairy

(EMBARASSED LAUGH) let's not get into
that.

HOMER

Hey, what the hell is that geek
Flanders doing on TV?

TRANS.

NOTES

FILM ROMAN

THE SIMPSONS

TITLE _____

SHOW 2F03

ACT II

PAGE 108

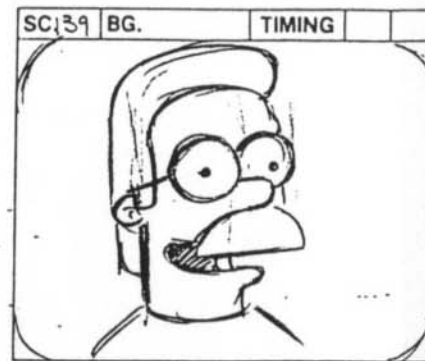
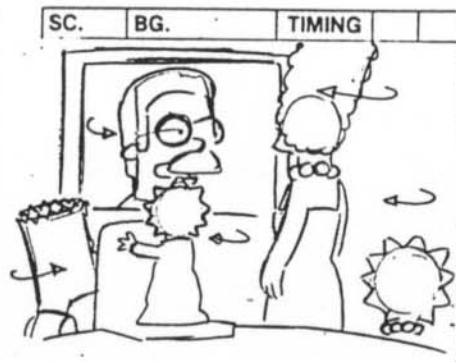
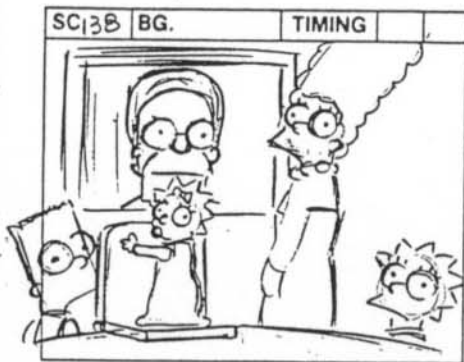
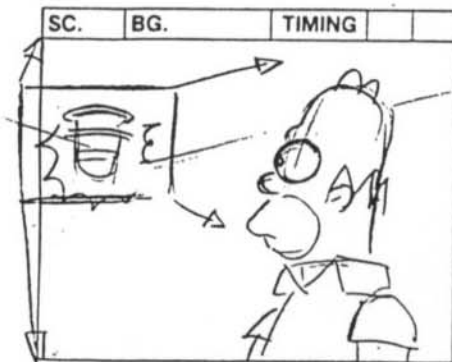

ACTION

TROMBONE TRUCK OUT

TRANS.

DIAL

TRANS.

NOTES

FLANDERS

Oh... Oh, I see by the big board we've got a Negative Nellie in Sector Two. I'm afraid I'm going to have to ask the whole family to kinda freeze and prepare for re-Neduction.

FILM ROMAN

THE SIMPSONS

TITLE _____

SHOW 2603 ACT II PAGE 109

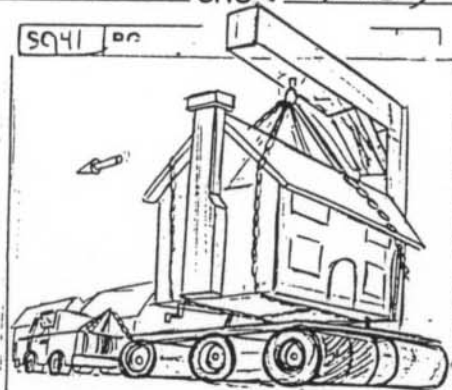
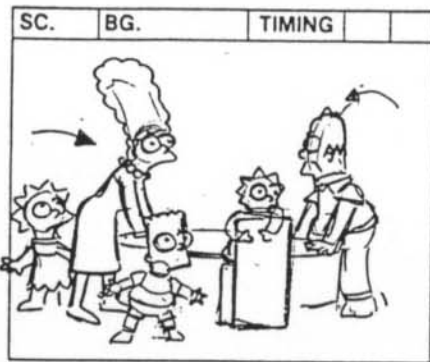
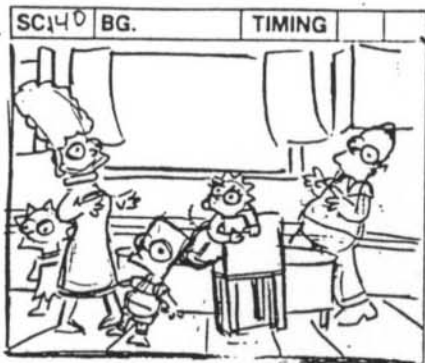

* SEE
CRANE
DESIGN

ACTIC

ALL REACT TO A JOLT
AS HOUSE SHAKES

SEE VERT. PAN BG
THRU WINDOW
ALL REGAIN
THEIR BALANCE

EXT. STREET - CONTINUOUS

We see the entire Simpson house is being towed away on a high tech platform.

TRANS.

DIAL

TRANS.

NOTES

FILM ROMAN

THE SIMPSONS

TITLE _____

SHOW 2F03

ACT II

PAGE 110

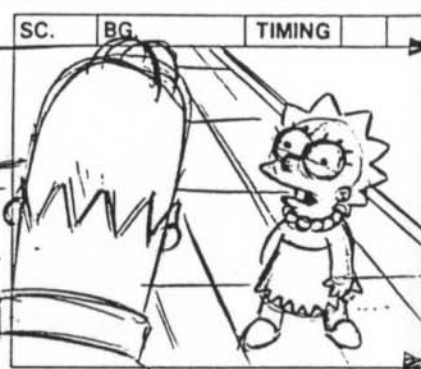
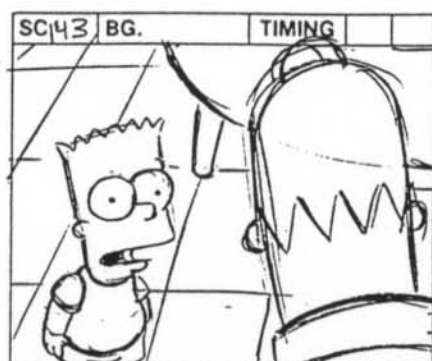
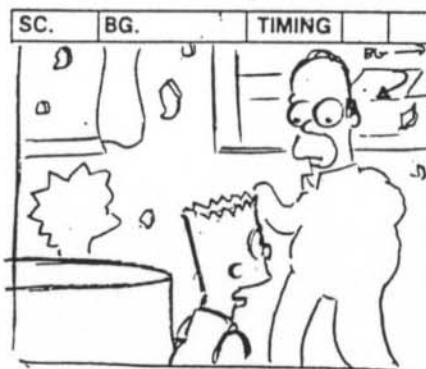
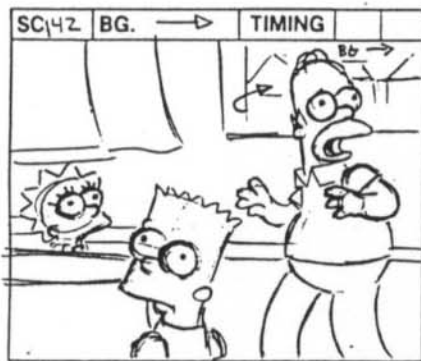

ACTION

PLASTER FALLS

TRANS.

DIAL

HOMER

(UPSET) What's going on here?

BART

Oh, Dad, you know as well as we do.
Flanders is the unquestioned lord and
master of the world.

LISA

He's created a near perfect society

TRANS.

NOTES

FILM ROMAN

THE SIMPSONS

TITLE _____

SHOW 2E03

ACT II

PAGE 111

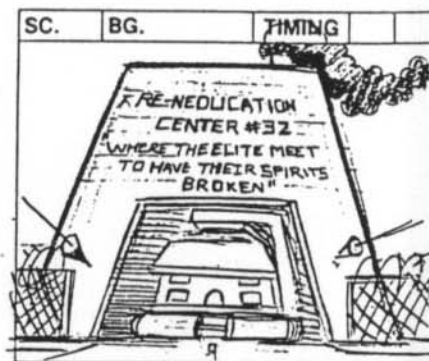
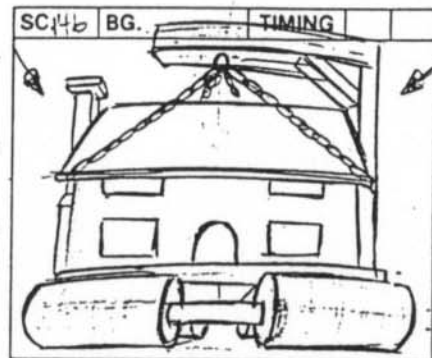
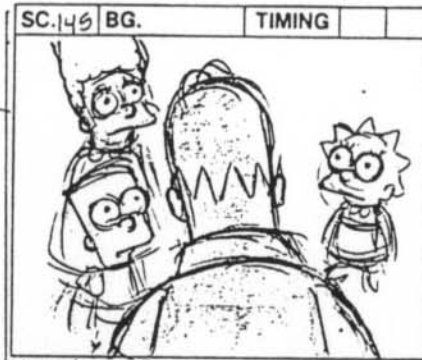
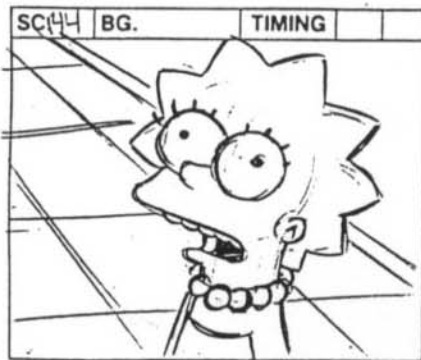

ACTION

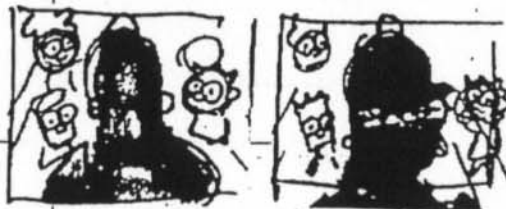

EXT. FREEWAY

They drive through a gate marked: "RE-NEDUCATION CENTER #32. 'WHERE THE ELITE MEET TO HAVE THEIR SPIRITS BROKEN'"

TRANS.

Post #32

DIAL

where there's no crime, hunger or war,
and all have access to the lively arts.

HOMER
(A LA CHARLTON HESTON) If that's your
world, I don't want to live in it.

*Truck in
to sign.*

TRANS.

NOTES

FILM ROMAN

THE SIMPSONS

TITLE _____

SHOW 2F03

ACT II

PAGE 112

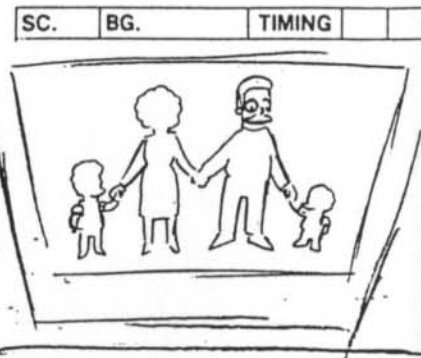
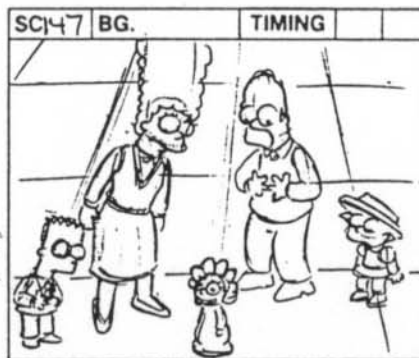
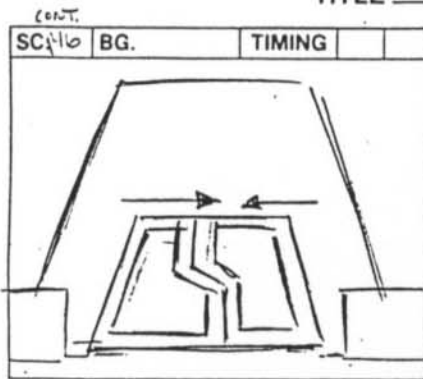

ACTION

TRANS.

DIAL

TRANS.

NOTES

INT. GRAY ROOM

The Simpsons are in a room, dressed like the Flanders family. Homer is wearing a sweater and chinos. Marge is in a simple dress. The kids are dressed for church. The Flanders family appears in front of them on a giant video screen, dressed exactly like them.

FLANDERS

Greetings, boo-boo makers! Oh look, sorry for the inconvenience.

FILM ROMAN

THE SIMPSONS

TITLE _____

SHOW 2F03

ACT II

PAGE 113

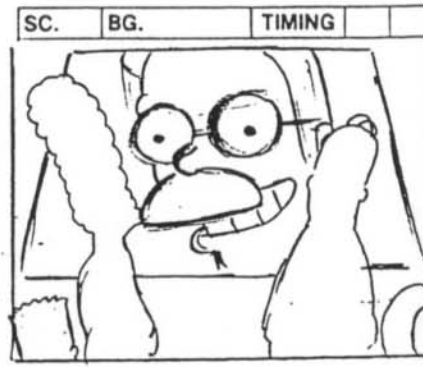
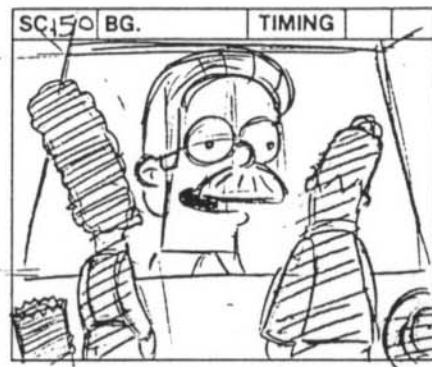
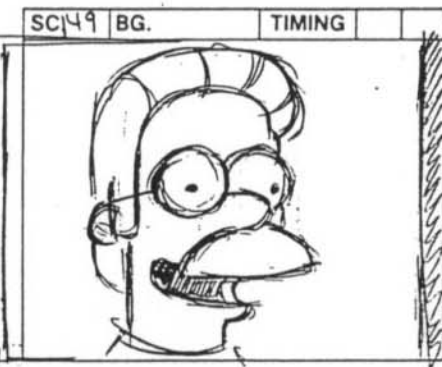
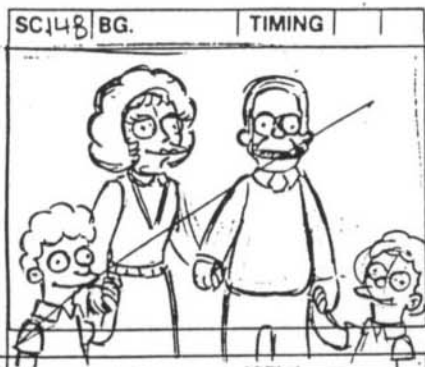

ACTION

close this cut

TRANS.

DIAL

I
guarantee by the time we're done you're
gonna walk out of this place happy.

If
you're not happy, I'm not happy. And
if I'm not happy, you're gonna wish you
were dead.

Everybody happy?

TRANS.

NOTES

FILM ROMAN

THE SIMPSONS

TITLE _____ SHOW 263 ACT II PAGE 114

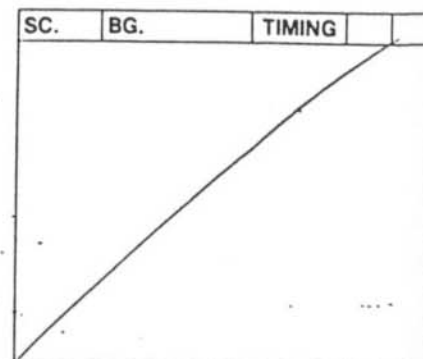
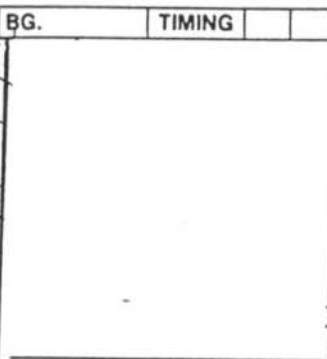
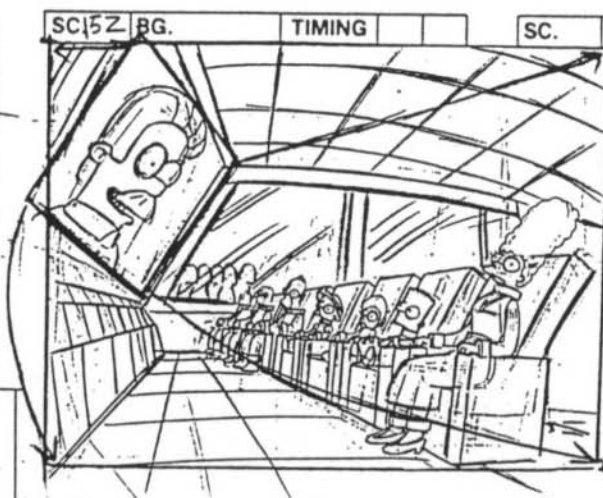
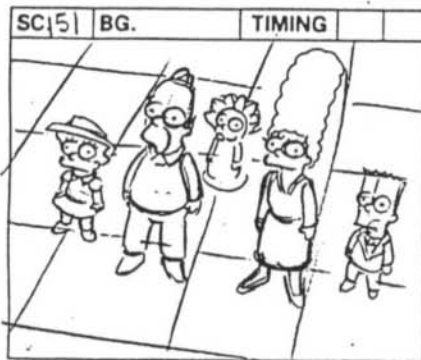

ACTION

PICK UP - SIMPSONS
REACTION
(MAGGIE FALL?)

TRANS.

INT. HIGH TECH ROOM

Everyone is strapped into chairs. Flanders is on yet another screen.

DIAL

FLANDERS

Okay, everybody. Let's see some big smiles.

TRANS.

NOTES

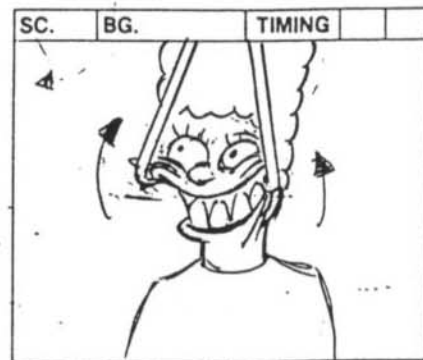
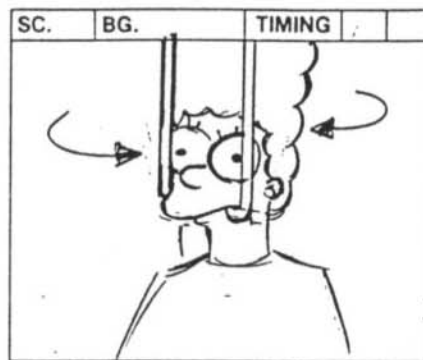
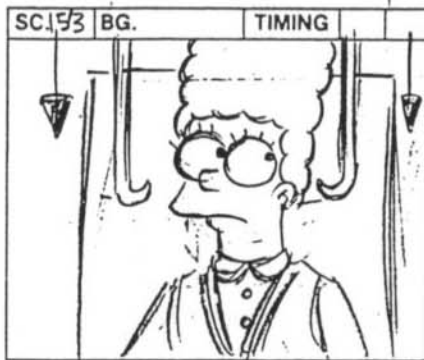

ACTION

Two metal hooks lower from the ceiling over each person. The hooks grab the corners of each person's mouth and yank their faces into painful rictus-type smiles.

TRANS.

DIAL

TRANS.

NOTES

CONT.
SC 153

2F03

II

116

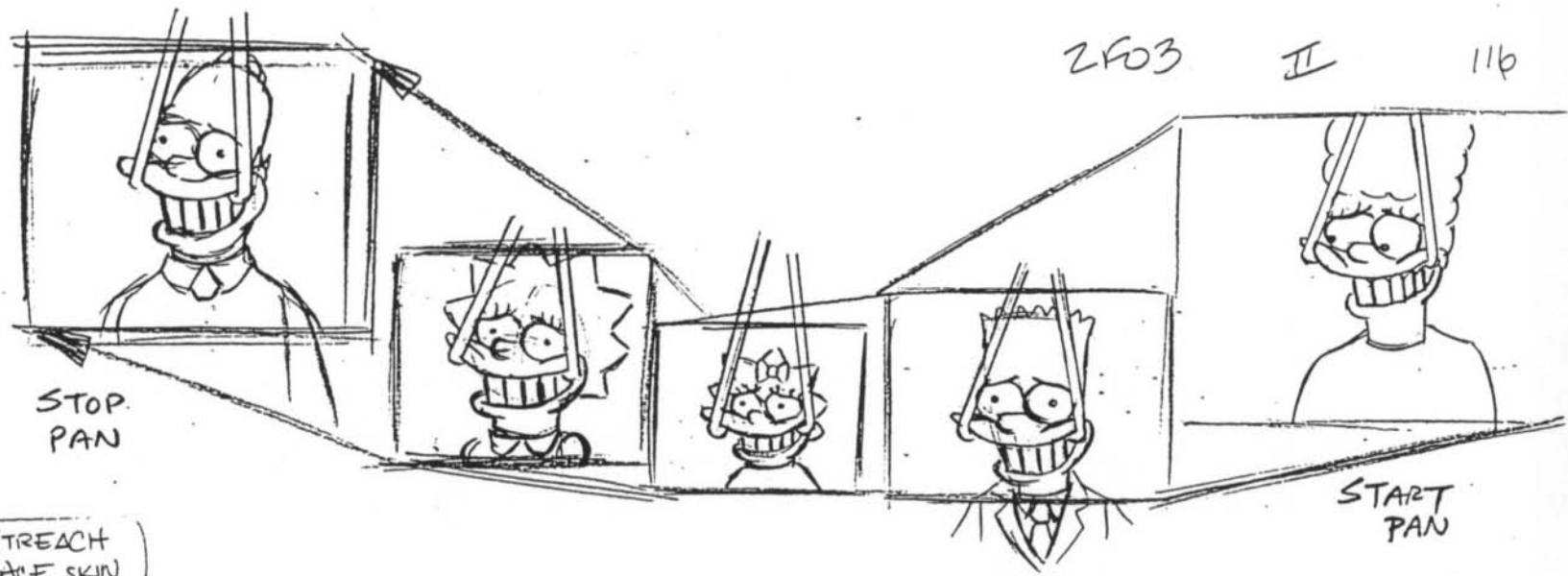

STOP
PAN

START
PAN

STREACH
FACE SKIN
AS IN
PREVIOUS
PANEL



FLANDERS (CONT'D) (V/O)

Just relax and let the hooks do their work.

FILM ROMAN

THE SIMPSONS

SHOW 2F03 ACT II PAGE 117

TITLE _____

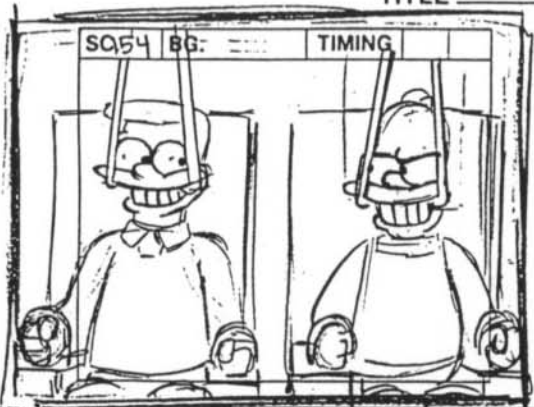

ACTION

h his eyes, Homer looks at the person next to him.

TRANS.

DIAL

HOMER

(HOOKS IN MOUTH) What the hell are you smiling at?

TRANS.

NOTES

SC 55	BG.	TIMING

SC.	BG.	TIMING

SC.	BG.	TIMING

DESIGN:
NOTE:
SIMPSONS STILL
IN THEIR
FLANDERS-LIKE
COSTUMES

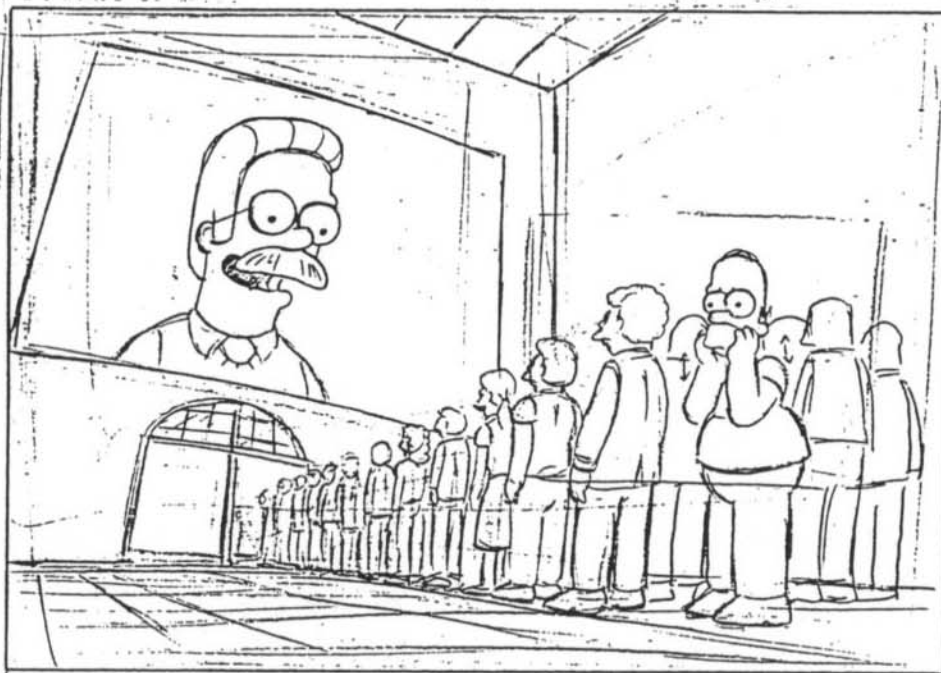

IAN

INT. CORRIDOR

Homer is standing in line, still rubbing his tender mouth. Ned is on another ever-present monitor.

FLANDERS

Now, in case all that smilin' didn't cheer ya up, there's one thing that never fails.

FILM ROMAN

THE SIMPSONS

TITLE _____

SHOW 2F03

ACT II

PAGE 118



ACTIC

ON HOMER IN
LINE (CONT)
→

TRANS.

DIAL

A nice glass of warm
milk, a little nap and a total frontal
lobotomy.

TRANS.

NOTES

FILM ROMAN

THE SIMPSONS

SHOW 2903 ACT II PAGE 119

TITLE _____

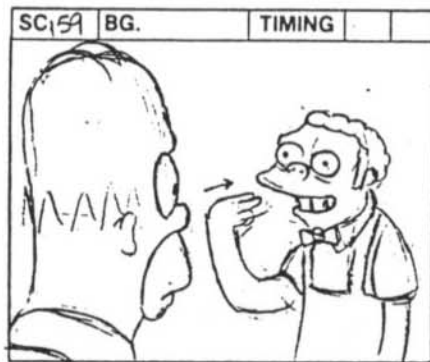
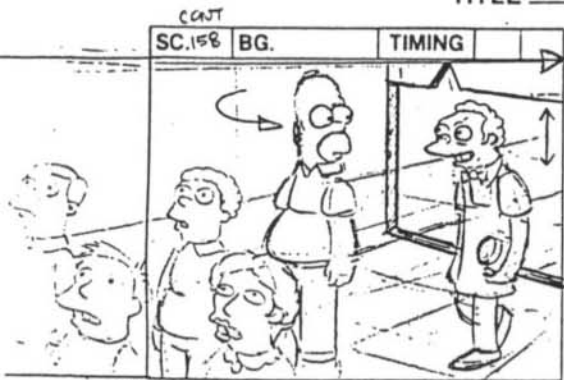

ACTION

A zombie-like Moe walks up to Homer.

MOE'S HAND
GOES THRU
NOSE-PULLING MOTION

He holds up a jar with a small chunk of brain floating in it.

TRANS.

DIAL

walks out before line

MOE

(EERILY CALM AND CHEEFUL) It's not so bad, Homer.

T-1

They go in through your nose. And they let you keep the piece of brain they cut out.

MOE (CONT'D)

(CUTE TALK, TO BRAIN) Oooo,

TRANS.

Look.

hello.

NOTES

FILM ROMAN

THE SIMPSONS

TITLE _____

SHOW 2F03

ACT II

PAGE 120

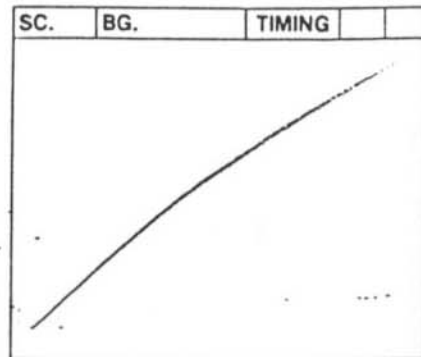
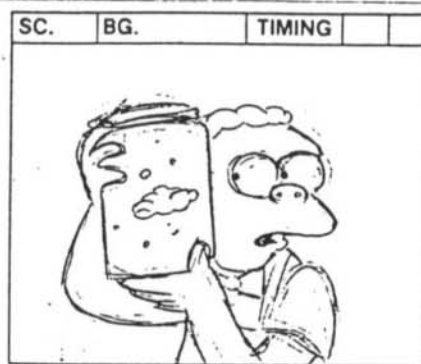

ACTION

MOE KNOCKS ON JAR



TRANS.

Homer in shot.

DIAL

Hello there. Who's that big man there? Who's da?

TRANS.

NOTES

FILM ROMAN

THE SIMPSONS

TITLE _____

SHOW 2403

ACT II

PAGE 121

SC.	BG.	TIMING
<p>MARGE START DIAL HERE (SEC NEXT PAGE)</p>		

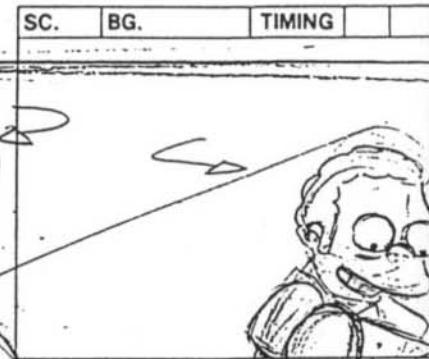
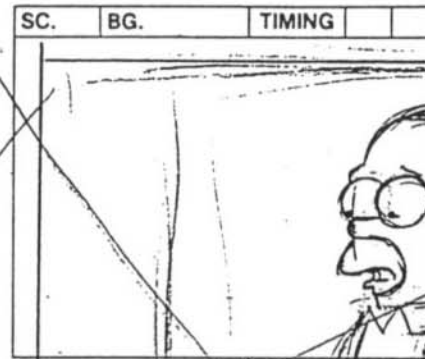
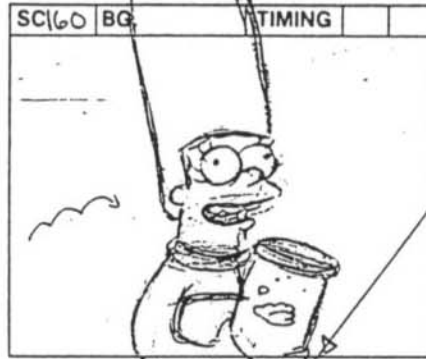

ACTION

TRANS.

DIAL

TRANS.

NOTES

Homer looks up and sees his lobotomized family with brain jars as well.

LISA/BART
(LIFELESS AND SCARY) Join us, Father.

*Marge doesn't
walk off*

FILM ROMAN

THE SIMPSONS

TITLE _____

SHOW 2F03

ACT II

PAGE 122

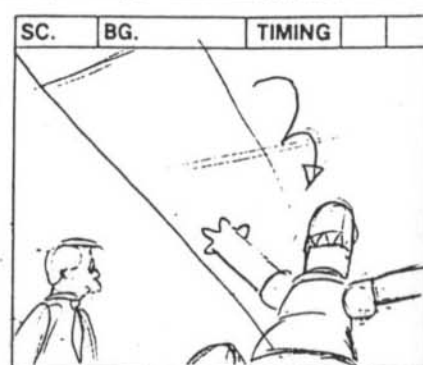
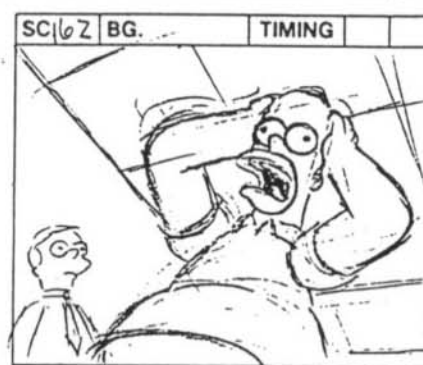
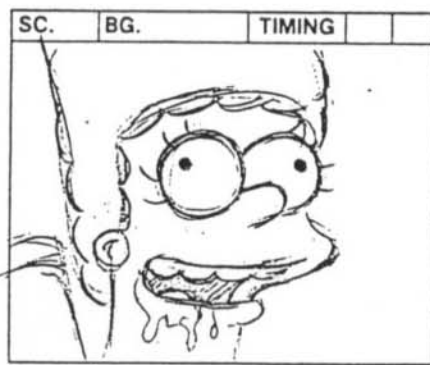
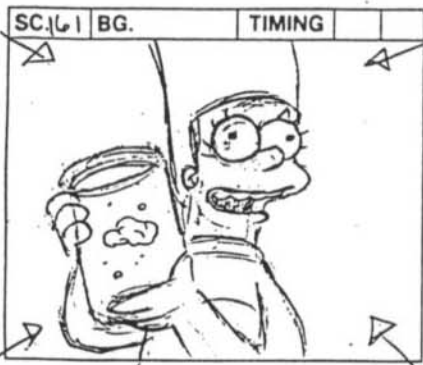

ACTION

Marge drools mindlessly.

TRANS.

*Holds w/
one hand*

DIAL

TRANS.

MARGE
(EXTREME MONOTONE) It's Bliiiiisssss.

Nooooo!

HOMER

NOTES

FILM ROMAN

THE SIMPSONS

TITLE _____ SHOW 2F03 ACT II PAGE 123

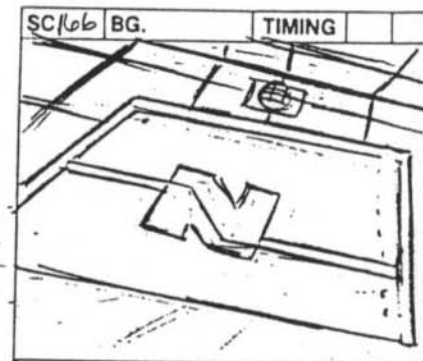
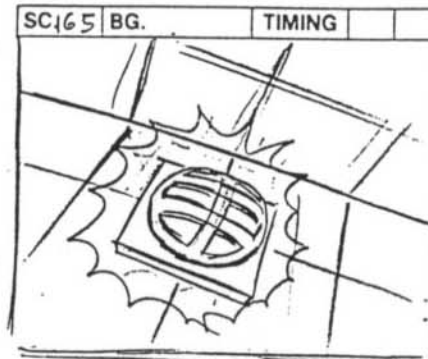
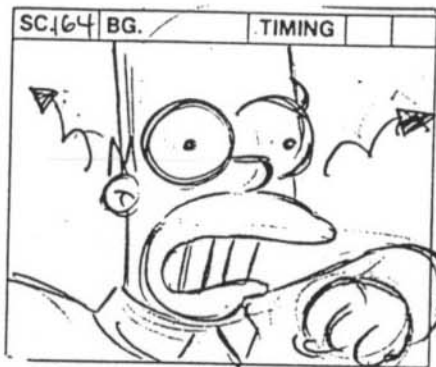
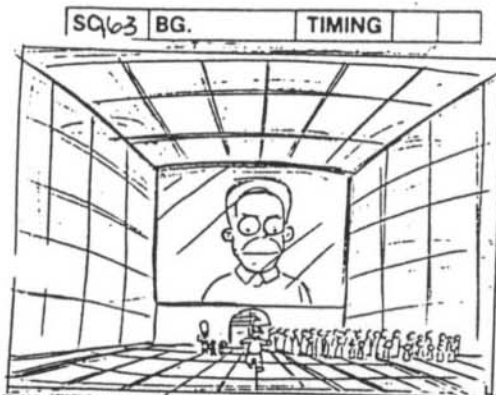

ACTION

HOMER RUNS UP
TO CAM.

Homer bolts. An ALARM goes off. We see a large ominous steel door raise up.

TRANS.

DIAL

TRANS.

NOTES

FILM ROMAN

THE SIMPSONS

TITLE _____

SHOW 2F03 ACT TI PAGE 124

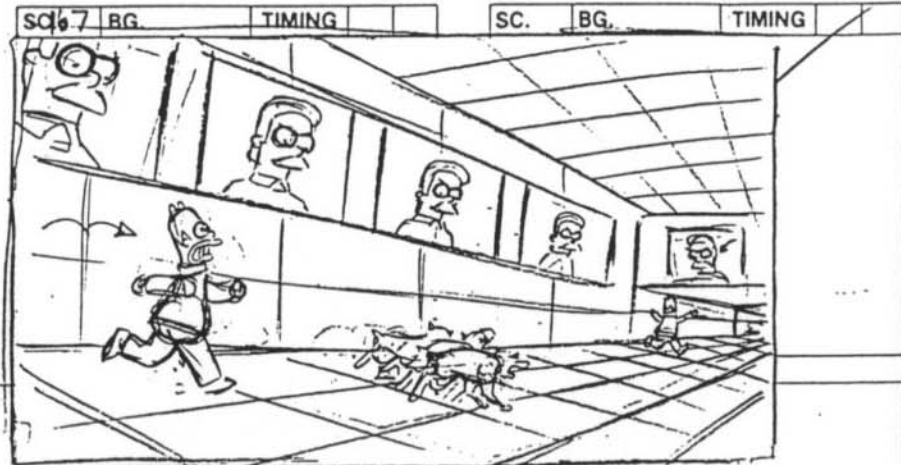
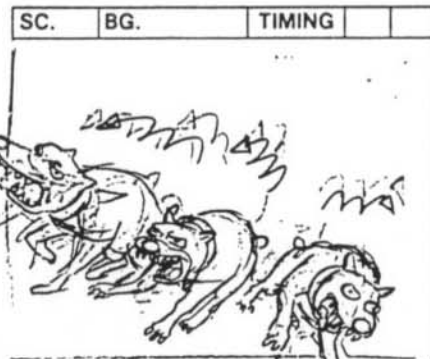
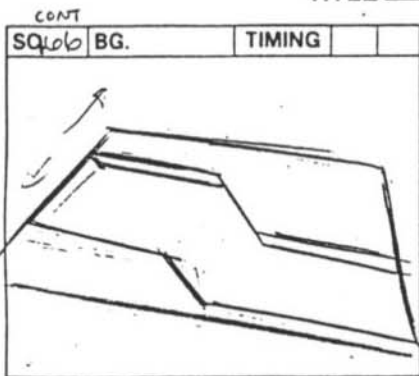

ACTION

TRANS.

DIAL

TRANS.

NOTES

START PAN → STOP

A pack of killer DOBERMANS comes charging out, BARKING. Homer runs.

THE SIMPSONS

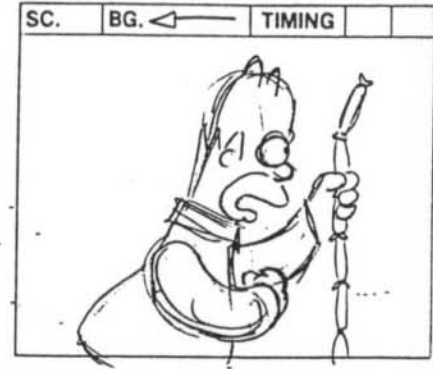
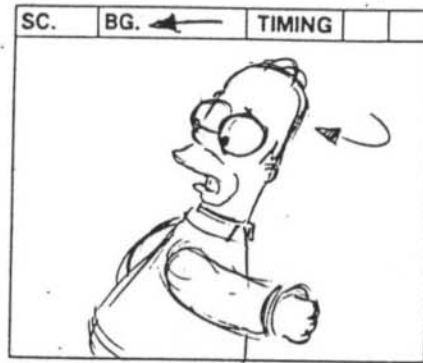
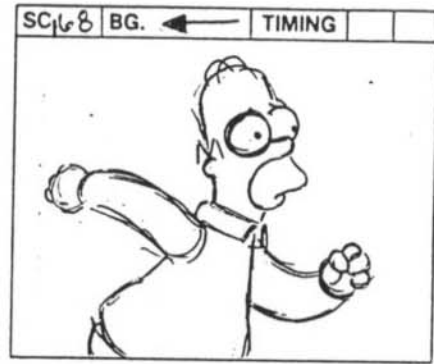

ACTION

TRANS.

DIAL

TRANS.

NOTES

HOMER
 Oh no! They're gaining on me. Wait, I have an idea *pull 'em out.*

FILM ROMAN

THE SIMPSONS

TITLE _____

SHOW 2F03

ACT II

PAGE 12b

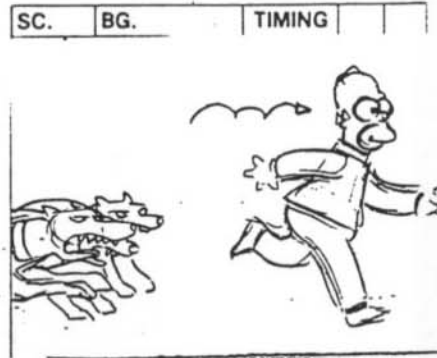
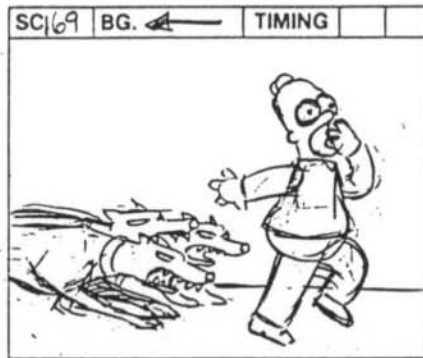
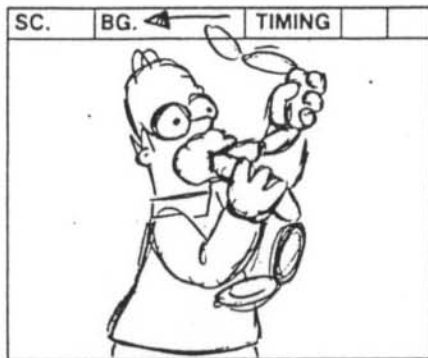
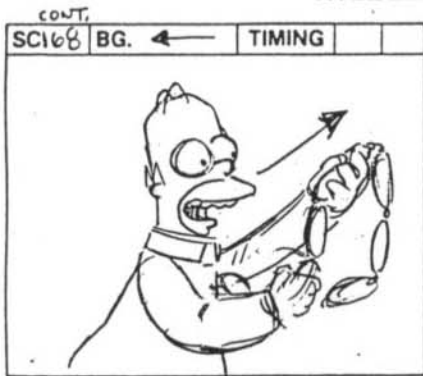

ACTION

Homer pulls a string of wieners from his pocket.

Homer GULPS the wieners, and then does indeed leave the dogs in the dust.

CAM-GAINS w/HOMER



TRANS.

Eats more slowly

DIAL

HOMER (CONT'D)

These wieners will give me the quick energy I need to escape.

TRANS.

NOTES

FILM ROMAN

THE SIMPSONS

TITLE

SHOW 202

ACT II PAGE 127

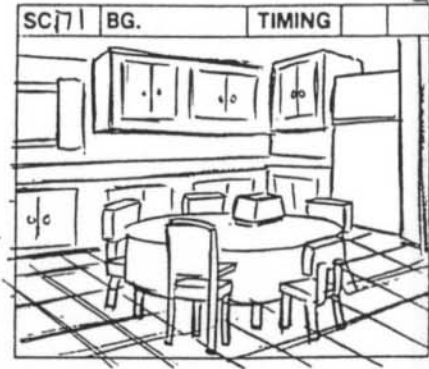
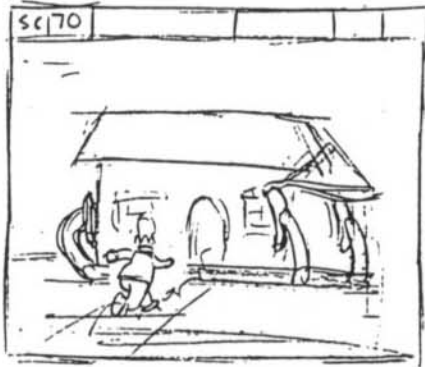

ACTION

TRANS.

DIAL

TRANS.

NOTES

INT. KITCHEN

FILM ROMAN

THE SIMPSONS

SHOW 2F03 ACT II PAGE 128

TITLE _____

CONT

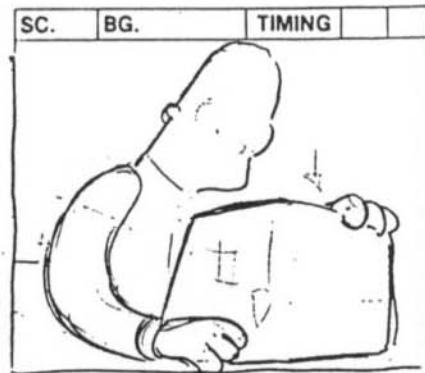
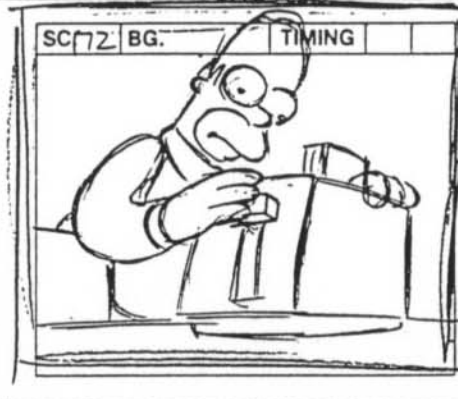
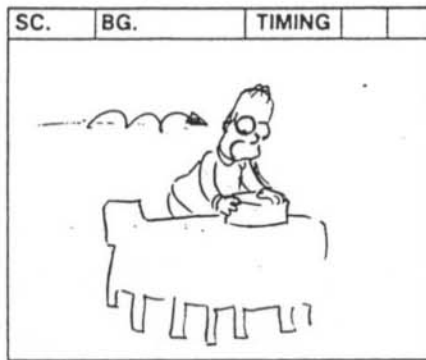
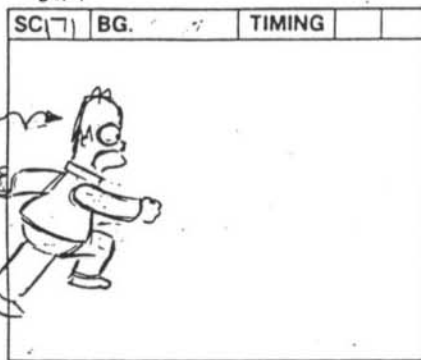

ACTION

Homer runs in, grabs the toaster and pushes down on the lever.

TRANS.

DIAL

TRANS.

NOTES

FILM ROMAN

THE SIMPSONS

TITLE _____

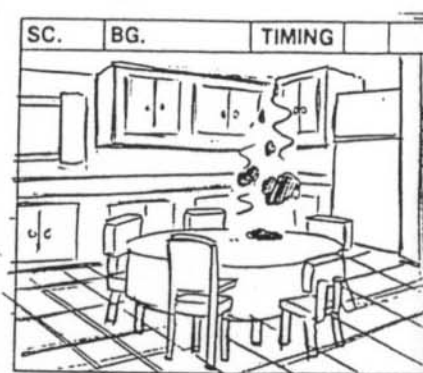
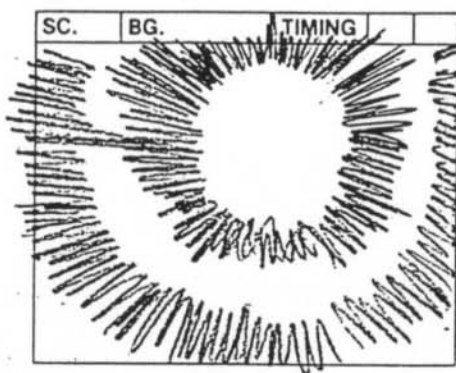
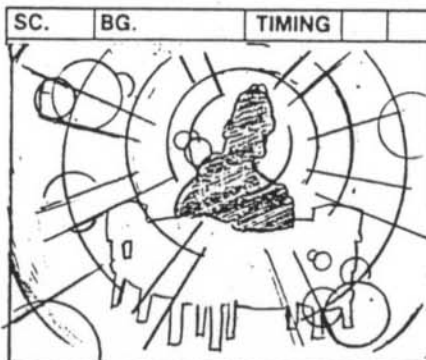
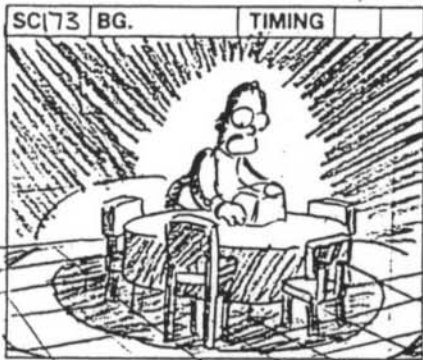
SHOW 2F03ACT IIPAGE 129

ACTION

He disappears in a BLINDING ARC OF LIGHT.

TRANS.

DIAL

TRANS.

NOTES

FILM ROMAN

THE SIMPSONS

TITLE _____

SHOW 2F03 ACT II PAGE 130

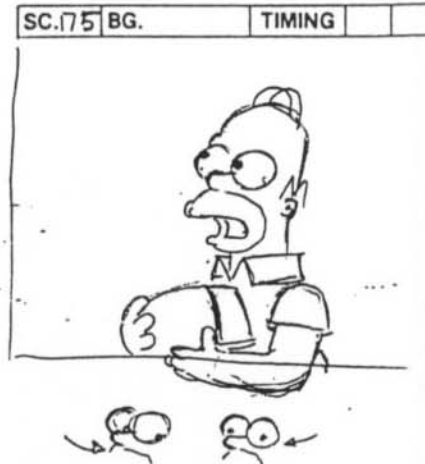
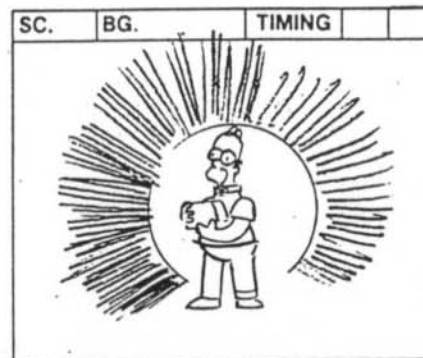
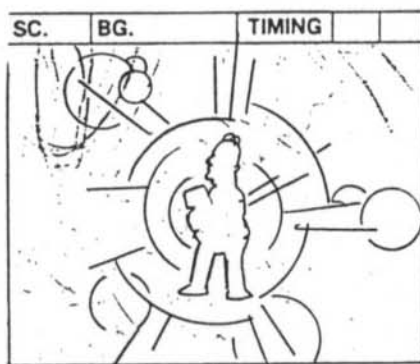
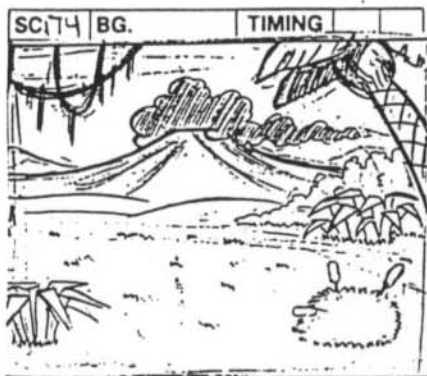

ACTION

EXT. SPRINGFIELD PRIMEVAL JUNGLE - 100 MILLION B.C.
Homer flashes back into scene.

TRANS.

DIAL

HOMER

This time I'm not gonna touch a thing.

TRANS.

NOTES

TITLE _____

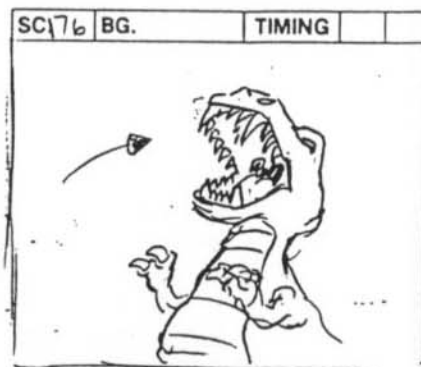
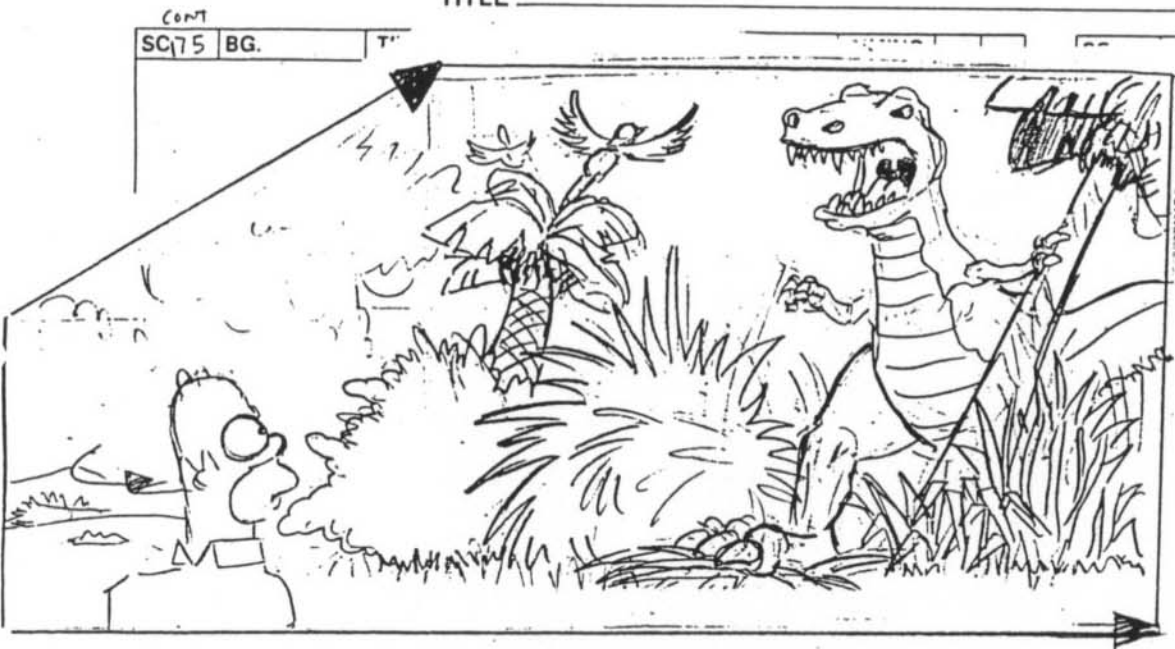
SHOW 2F03ACT IIPAGE 131

DIAL

Suddenly a T. REX BURSTS from the bushes and ROARS at Homer.

TRANS.

NOTES

FILM ROMAN

THE SIMPSONS

TITLE _____

SHOW 2F03

ACT II

PAGE 132

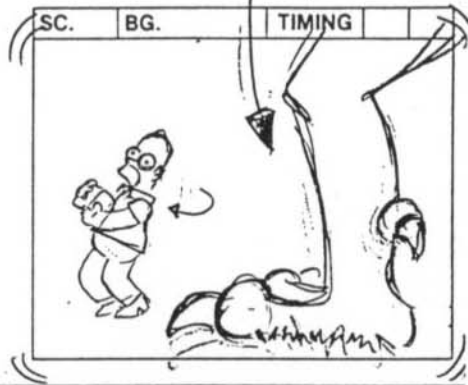
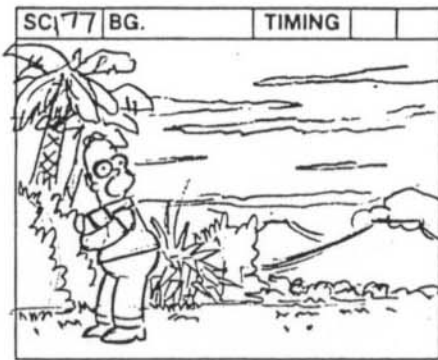
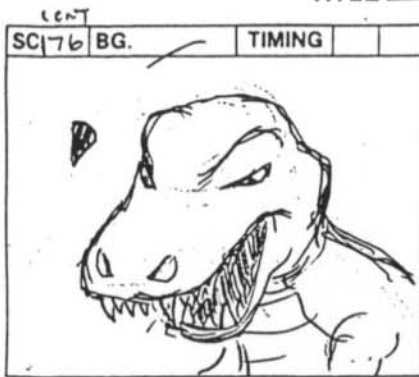

ACTION

Homer freezes, standing perfectly still.

TRANS.

DIAL

HOMER (CONT'D)

If there's one thing Spielberg has taught us, it's if you stand perfectly still, dinosaurs can't see you.

TRANS.

NOTES

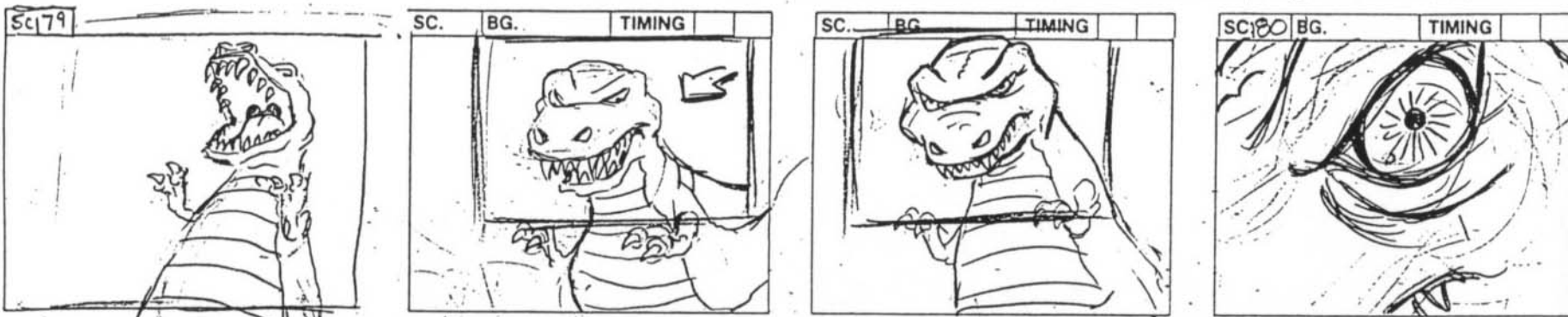

ACTION

less movement

ANIMATES TO THIS
PRIMAL

We see the dinosaur cock his head.

ANIMATES TO CAM.

TRANS.

DINOSAUR POV

Everything around and behind Homer is darkness, but Homer is clear and bright. The POV gets closer to Homer.

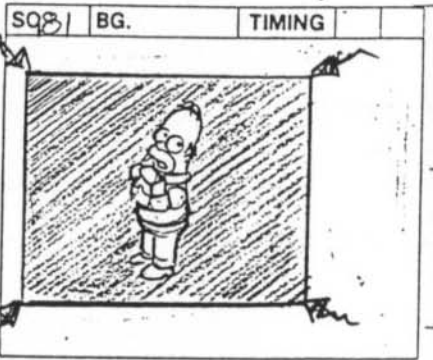

DIAL

TRANS.

HOMER

(QUIET UNDER BREATH, TAUNTING) Tyranna-doodie-head.

TRUCK IN
more smug

NOTES

TITLE _____

 SHOW 2F03

 ACT II

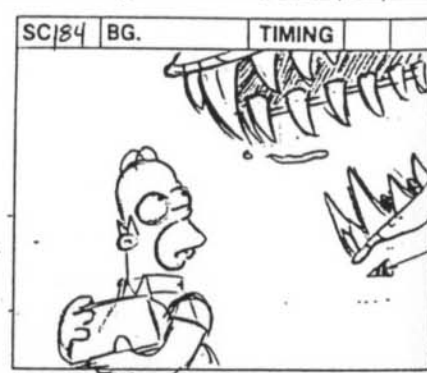
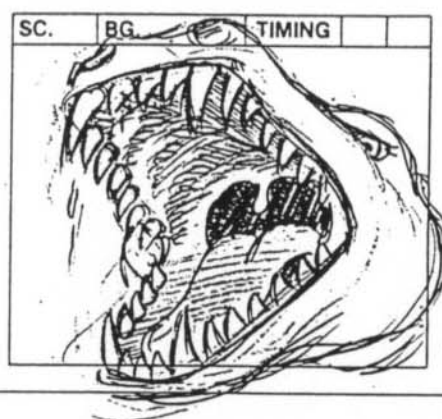
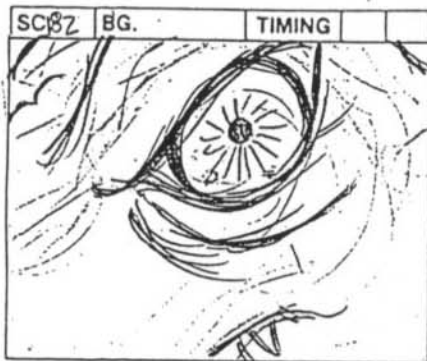
 PAGE 134

ACTION

BACK TO SCENE

The T. Rex lunges to bite Homer's head off.

CONT
→

TRANS.

DIAL

TRANS.

NOTES

FILM ROMAN

THE SIMPSONS

SHOW 2403 ACT II PAGE 135

TITLE _____

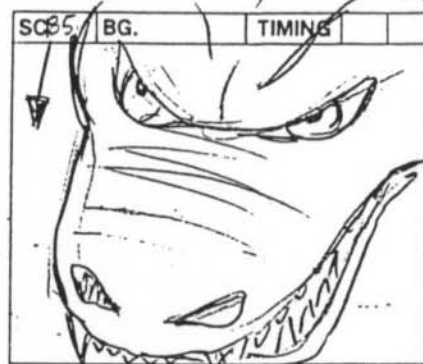
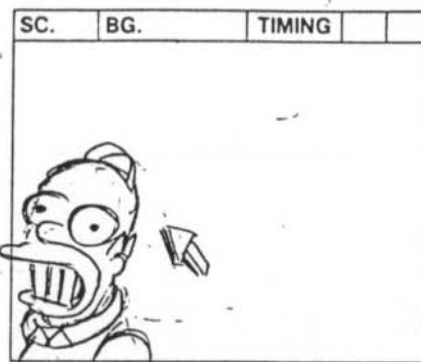
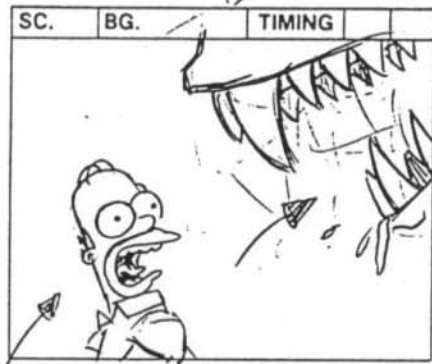
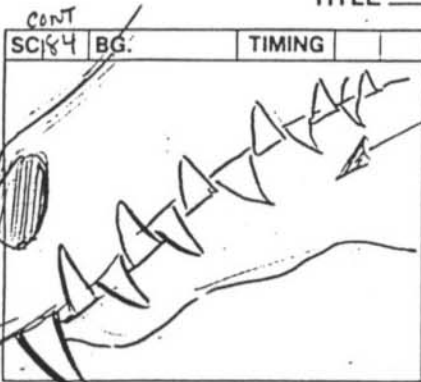

ACTION

He ducks just in time.

TRANS.

DIAL

(SCREAMS)
HOMER

TRANS.

NOTES

TITLE _____

SHOW 2803

ACT II

PAGE 136

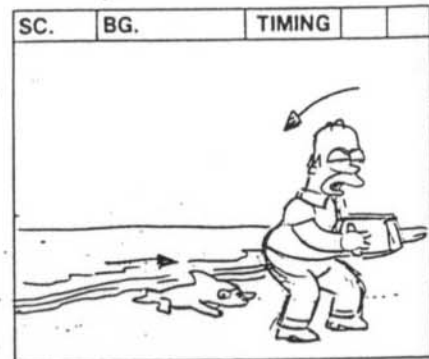
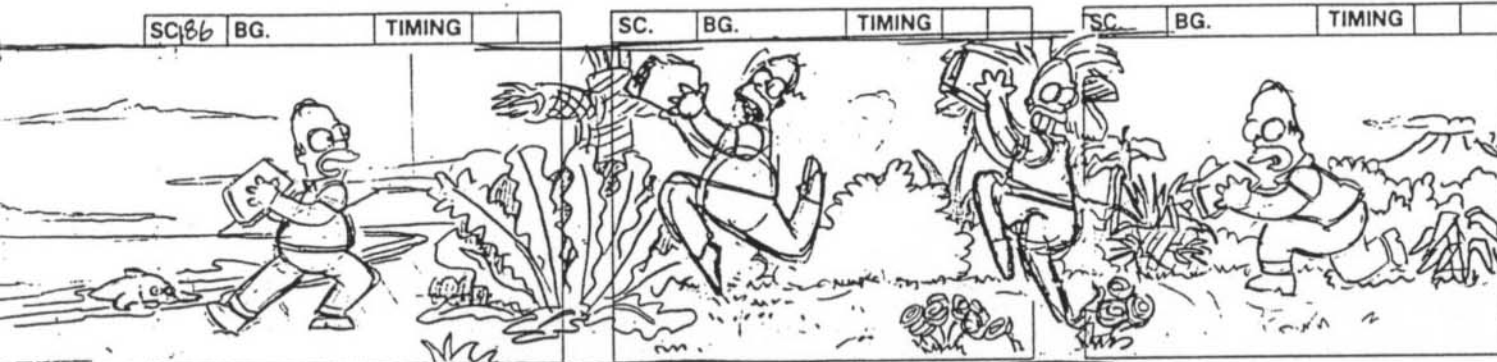

Homer begins running, but very gingerly and balletic.

Homer takes a deep breath and sits down.

TRANS.

DIAL

HOMER (CONT'D)

Mustn't crush. Mustn't kill. Made it!

TRANS.

NOTES

FILM ROMAN

THE SIMPSONS

TITLE _____

SHOW 2403

ACT II

PAGE 137

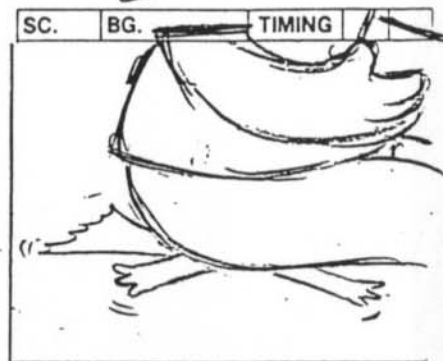
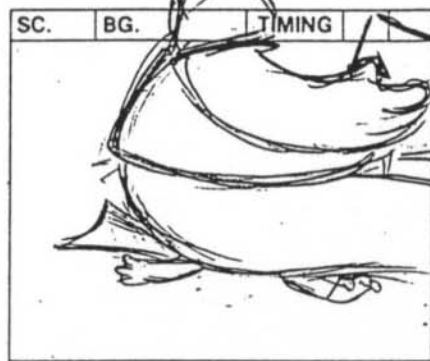
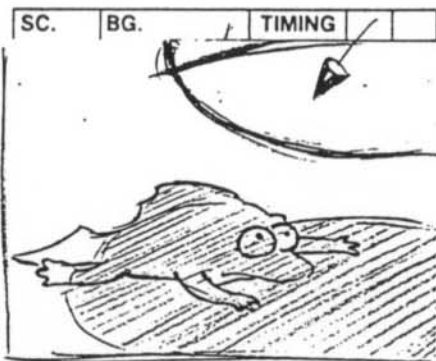
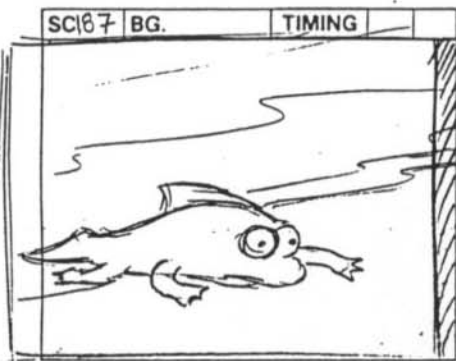

ACTION

which is just starting to pull itself onto dry land with
 its emerging limbs. CRUSHING a fish,

TRUCK OUT

CONT

TRANS.

DIAL

TRANS.

NOTES

FILM ROMAN

THE SIMPSONS

TITLE _____ SHOW 2F03 ACT II PAGE 138

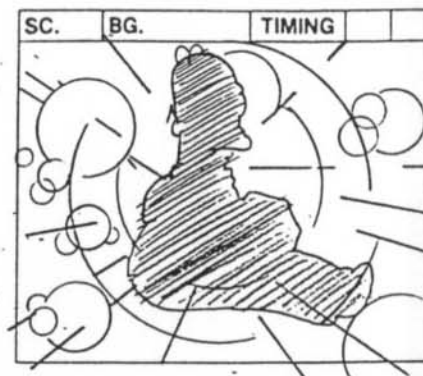
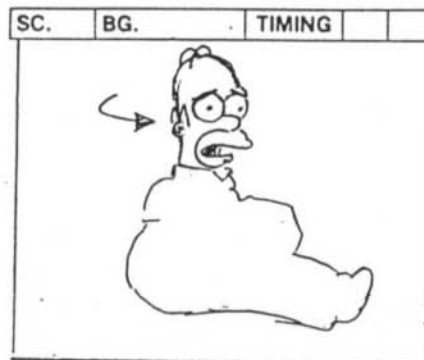
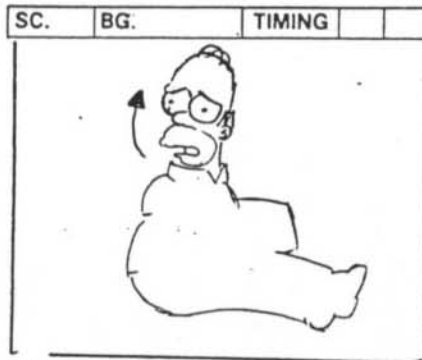
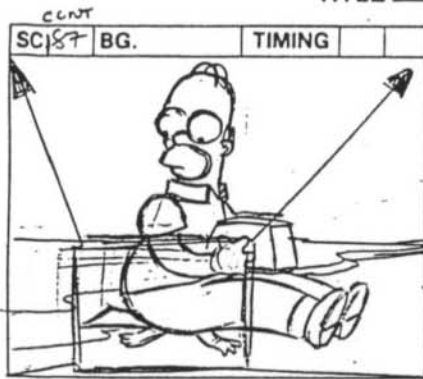

ACTION

TRANS.

DIAL

TRANS.

NOTES

HOMER (CONT'D)

(MOANS) Oh, I wish I wish I hadn't
killed that fish.

FILM ROMAN

THE SIMPSONS

TITLE _____

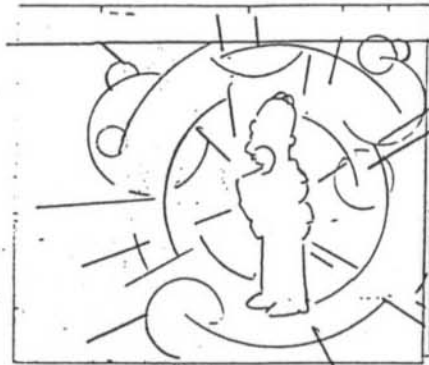
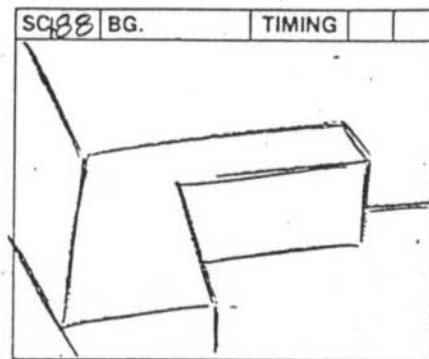
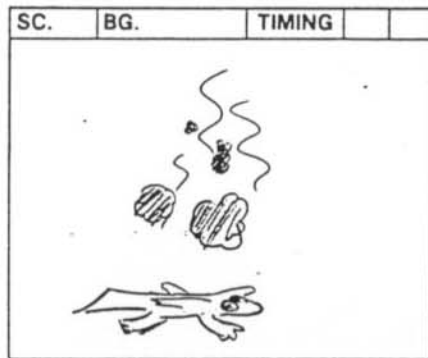
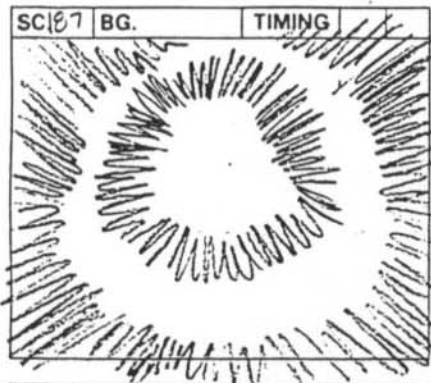
SHOW 2F03 ACT II PAGE 139

ACTION

RE-USE
ANIMATION

TRANS.

DIAL

TRANS.

NOTES

FILM ROMAN

THE SIMPSONS

TITLE _____

SHOW 2F03

ACT II

PAGE 140

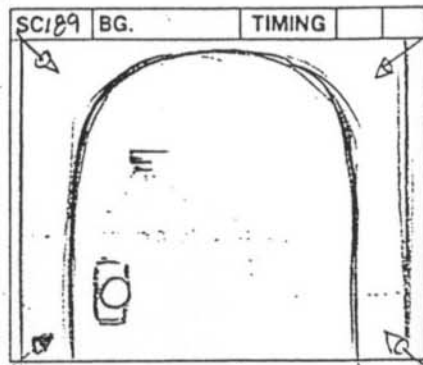
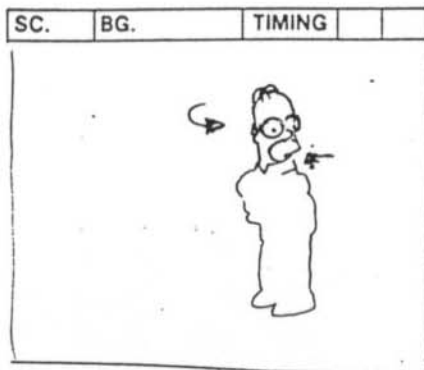
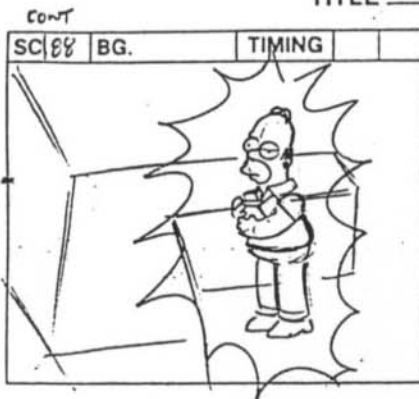

ACTION

RE-USE ANIMATION

TRUCK IN

TRANS.

DIAL

TRANS.

NOTES

FILM ROMAN

THE SIMPSONS

TITLE _____

SHOW 2F03 ACT II PAGE 41

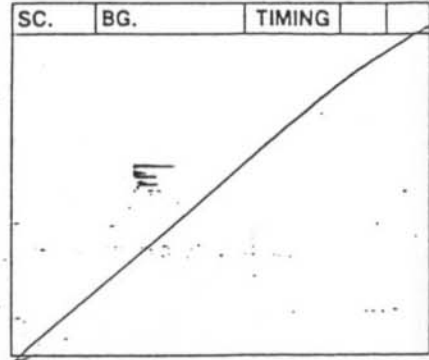
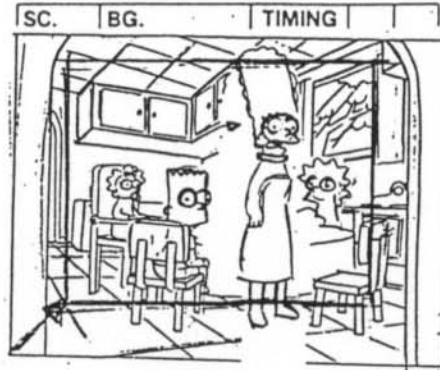
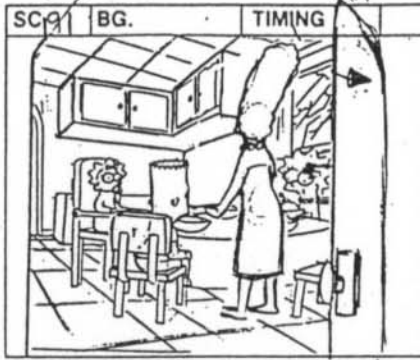
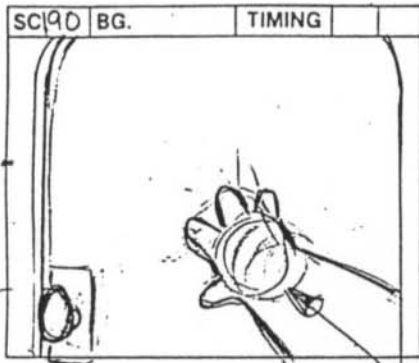

ACTION

Re-use

INT. KITCHEN - SECONDS LATER

The family in the kitchen as before.

< >
R
swings O.S

TRANS.



DIAL

A fearful Homer appears at the door.

MARGE
(TURNING) Svevo...?

TRANS.

NOTES

FILM ROMAN

THE SIMPSONS

TITLE _____

SHOW 2903

ACT II

PAGE 142

SC.	BG.	TIMING		
-----	-----	--------	--	--

SC. 42	BG.	TIMING		
--------	-----	--------	--	--



SC.	BG.	TIMING		
-----	-----	--------	--	--

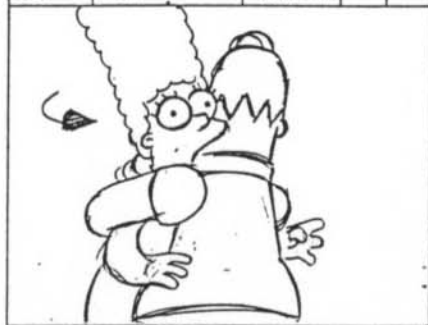

SC.	BG.	TIMING		
-----	-----	--------	--	--

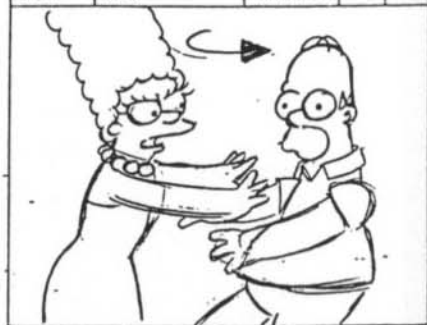

ACTIC

Homer, ignoring this, runs to Marge and embraces her.
Marge pushes him away in horror

CONT

TRANS.

DIAL

MARGE (CONT'D)
(ANGRILY) Svevo!

TRANS.

NOTES

FILM ROMAN

THE SIMPSONS

TITLE _____

SHOW 2F03

ACT II

PAGE 143

CONT.

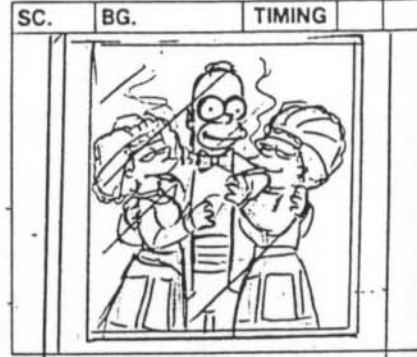
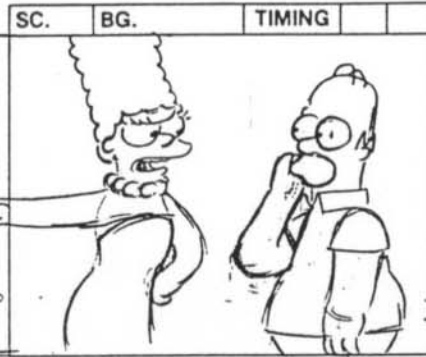
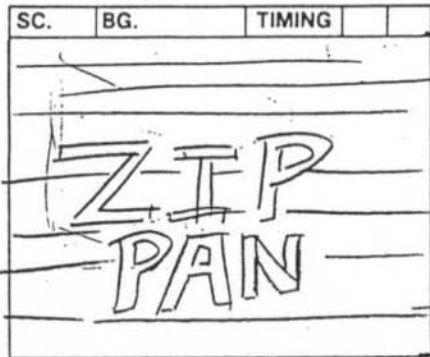
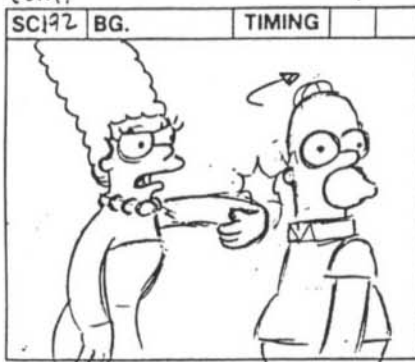

ACTION

and SLAPS him.

She gestures angrily to a framed wedding photo on the wall. It depicts Homer, the bridegroom, standing happily between Patty and Selma, both wearing wedding dresses.

TRANS.

Hold

DIAL

Svednyi dort maz vliet rral

TRANS.

NOTES

FILM ROMAN

THE SIMPSONS

2F03

II

144

TITLE _____



ACTION

Homer turns in horror to see Patty and Selma, both wearing sexy nightgowns and making bedroom eyes at him.

TRANS.

DIAL

HOMER
(TINY WHIMPER) Ohno.

PATTY (O.S.)
(CALLING, AMOROUS) Svevo...?

SELMA (O.S.)

(AMOROUS) Sve-vo dyort-nyi...

TRANS.

NOTES

FILM ROMAN

THE SIMPSONS

TITLE _____

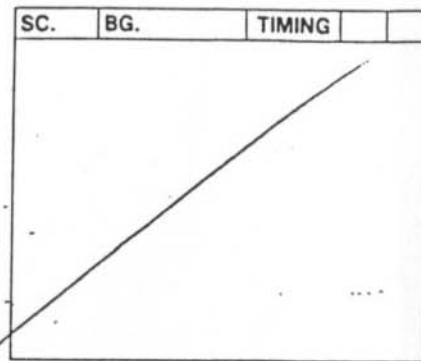
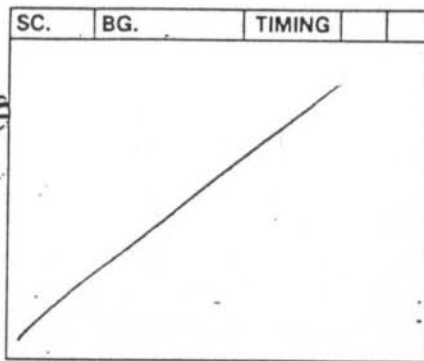
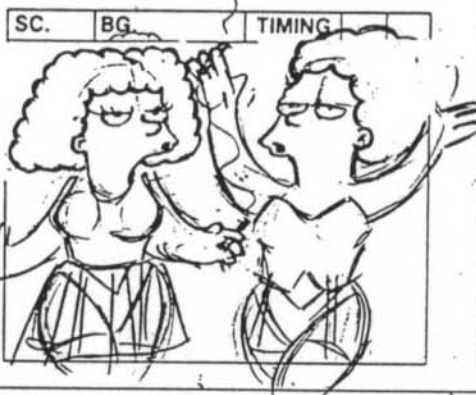
SHOW 2F03ACT IIPAGE 145

ACTION

TRANS.

DIAL

TRANS.

NOTES

(SMOOCHING NOISES)

FILM ROMAN

THE SIMPSONS

TITLE _____

SHOW 2FD3

ACT II

PAGE 146

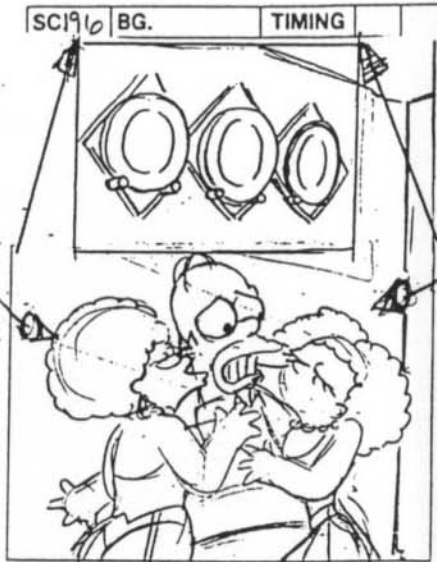
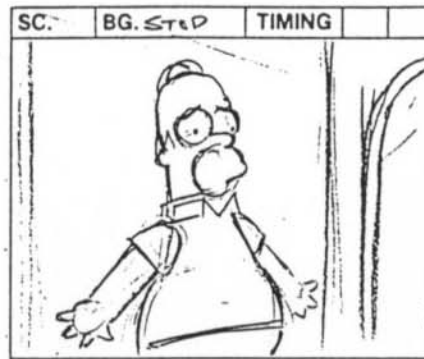
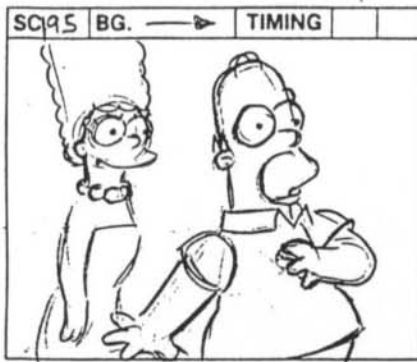

ACTION

PAN W/ HOMER

PAST

Homer, suddenly cornered, backs against a wall as they advance. they're on him like a pair of boa constrictors.

MARGE

ANGLE ON BREAKFAST DISHES RATTLING

SFX: VIOLENT STRUGGLE ACCOMPANIED BY AMOROUS COOING.

TRANS.

DIAL

TRANS.

NOTES

CONT.
SC. 195



FILM ROMAN

THE SIMPSONS

TITLE _____

SHOW 2F03

ACT II

PAGE 147

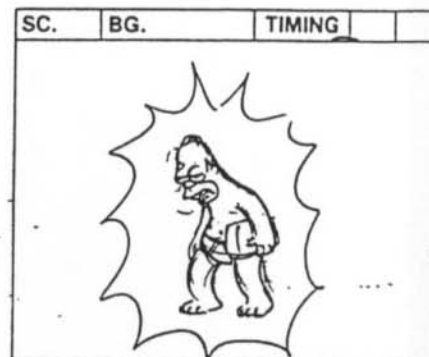
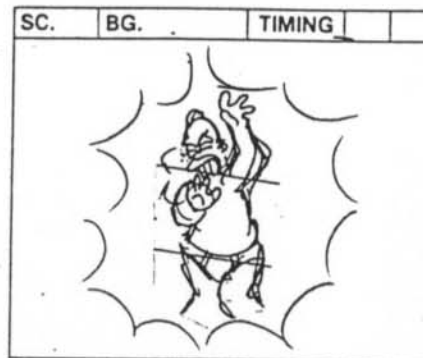
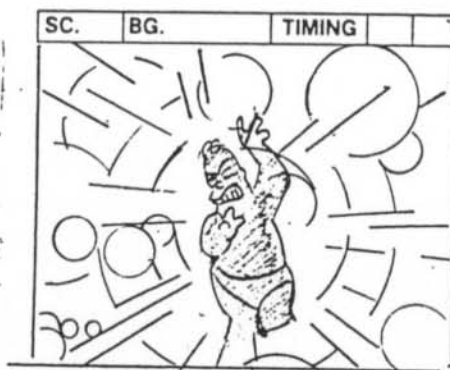
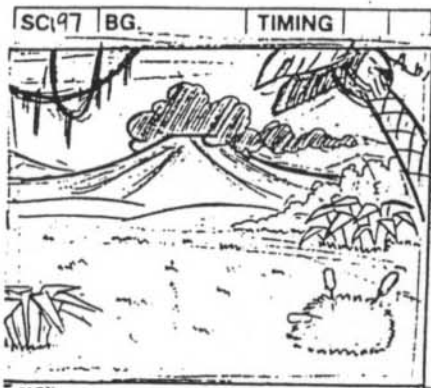

ACTION

HOLD ON BG

TRANS.

DIAL

TRANS.

NOTES

EXT. SPRINGFIELD JUNGLE - 100 MILLION B.C.

Homer appears in his underwear, with lipstick all over his head, HEAVING and GASPING.

FILM ROMAN

THE SIMPSONS

TITLE _____

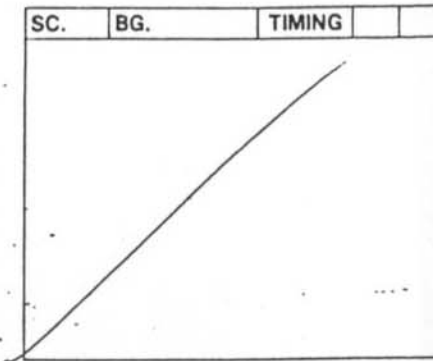
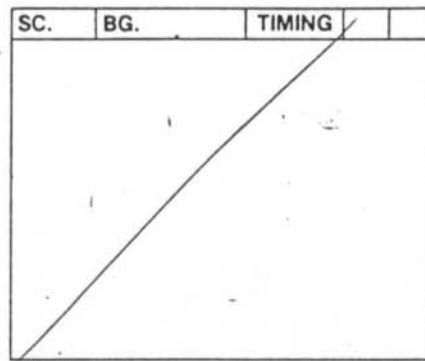
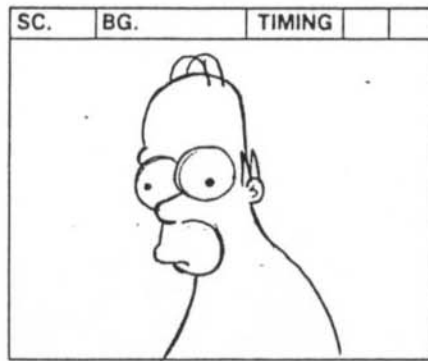
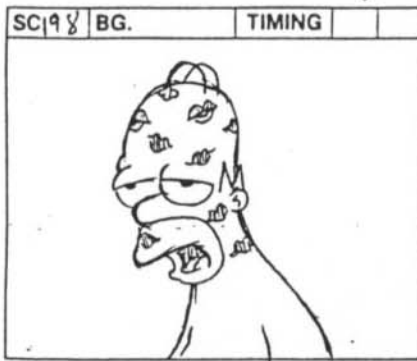
SHOW 2103ACT IIPAGE 148

ACTION

O.S.
T. REY
ROAR

CONT

TRANS.

DIAL

HEAVING / GASPING
CONTINUE

TRANS.

NOTES

FILM ROMAN

THE SIMPSONS

TITLE _____

SHOW 2503 ACT II PAGE 119SC. 99 | BG. | T

TIMING

RE-USE
ANIM.SC. 100 | BG. |

TIMING



DIAL

TRANS.

NOTES

The T. Rex BURSTS out of the bushes.

FILM ROMAN

THE SIMPSONS

TITLE _____

SHOW

2403

ACT

II

PAGE

190

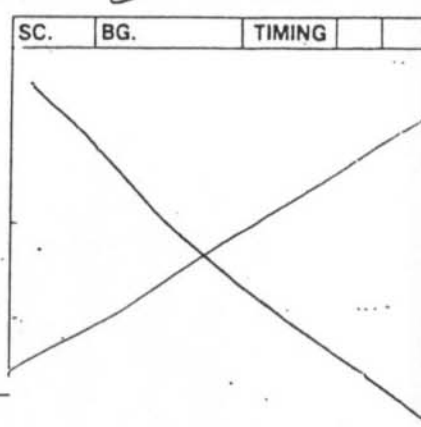
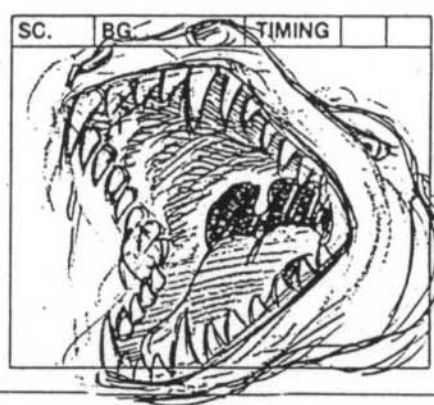
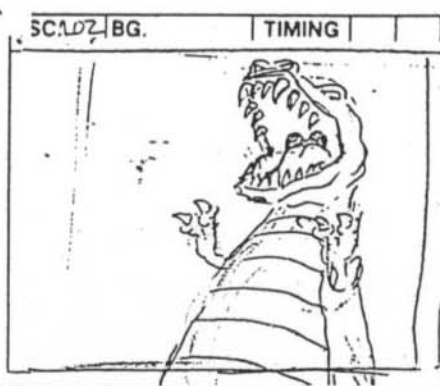
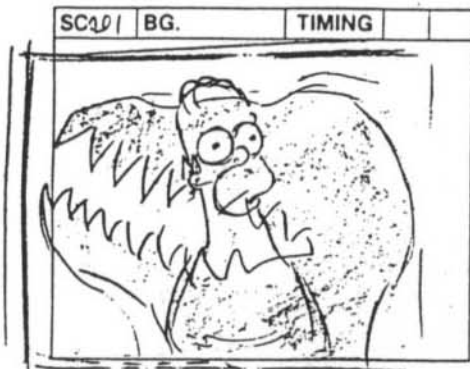

ACTION

P. V. HOMER

TRANS.

DIAL

TRANS.

NOTES

FILM ROMAN

THE SIMPSONS

TITLE _____

SHOW 2F03

ACT II

PAGE 151

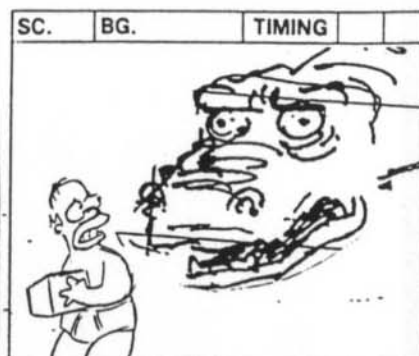
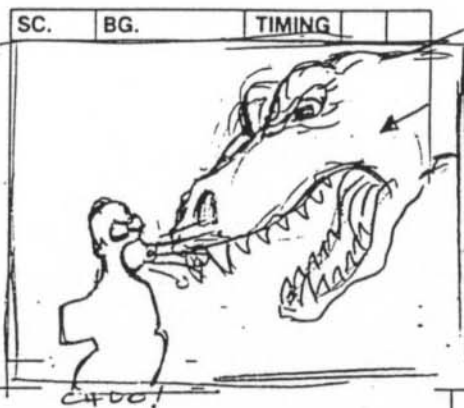
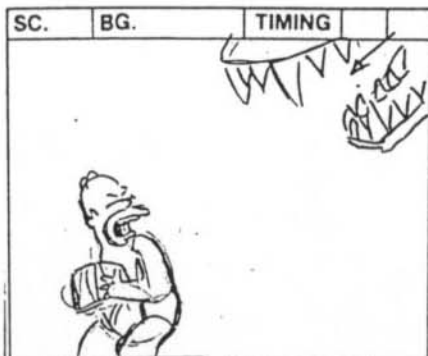
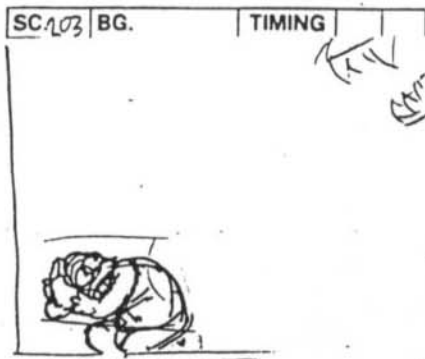

ACTION

AHH

CHOO!

T.REX RE-ACTS

homer SNEEZES. The T. rex stops short, catching Homer's germs.

TRANS.

DIAL

TRANS.

NOTES

FILM ROMAN

THE SIMPSONS

TITLE _____

SHOW 2F03ACT IIPAGE 192

SC. BG. TIMING

SC. BG. TIMING

SC. 104 BG. TIMING

SC. BG. TIMING



ACTIO

BACK TO SNEZE

. SNEEZES once.

TRANS.

DIAL

TRANS.

NOTES

FILM ROMAN

THE SIMPSONS

2F03 --- II

PAGE 153

TITLE _____

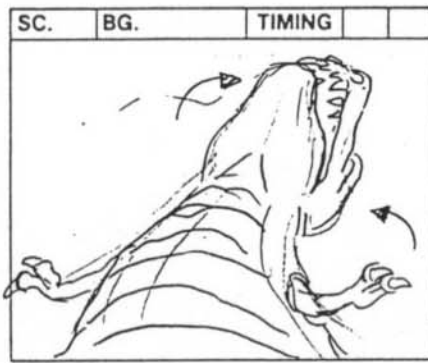

ACTION

then keels over dead.

TRANS.

DIAL

TRANS.

NOTES

FILM ROMAN

THE SIMPSONS

TITLE _____

SHOW 2F03

ACT II

PAGE 154

SC 105 | BG. | TIMING | SC. | BG. | TIMING



ACTION

SC. | BG. | TIMING | SC. | BG. | TIMING

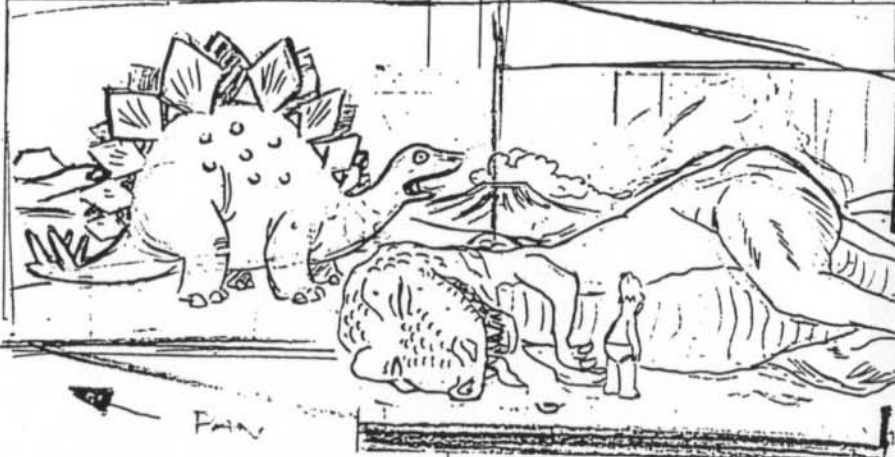

(CAM. SHAKE?)
AS T.REX FALLS

TRANS.

A dinosaur next to it SNEEZES and collapses.

DIAL

TRANS.

NOTES

FILM ROMAN

THE SIMPSONS

SHOW *2F03* ACT *FL* PAGE *199*

TITLE _____

CONT.

SC. *105*

BG.

TIMING

SC.

BG.

TIMING

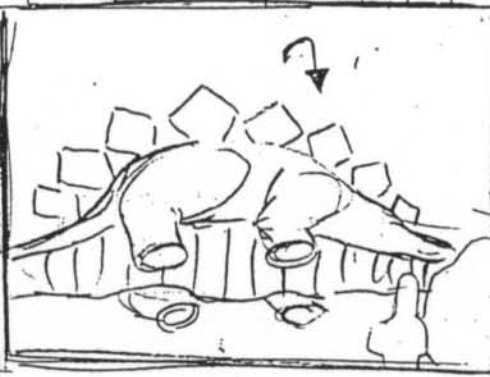
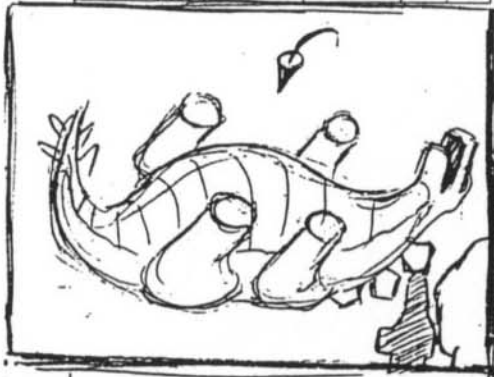

AC.

TRANS.

DIAL

TRANS.

NOTES

FILM ROMAN

THE SIMPSONS

TITLE _____ SHOW _____ ACT II PAGE 155A

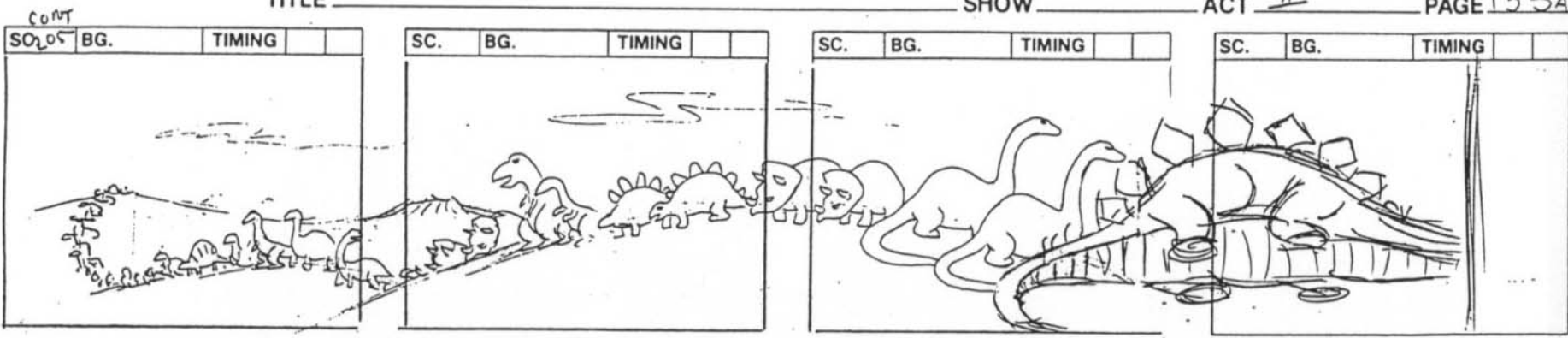

ACTION

TRANS.

DIAL

TRANS.

NOTES

FILM ROMAN

THE SIMPSONS

SHOW 2FD3 ACT II PAGE 1516

TITLE _____

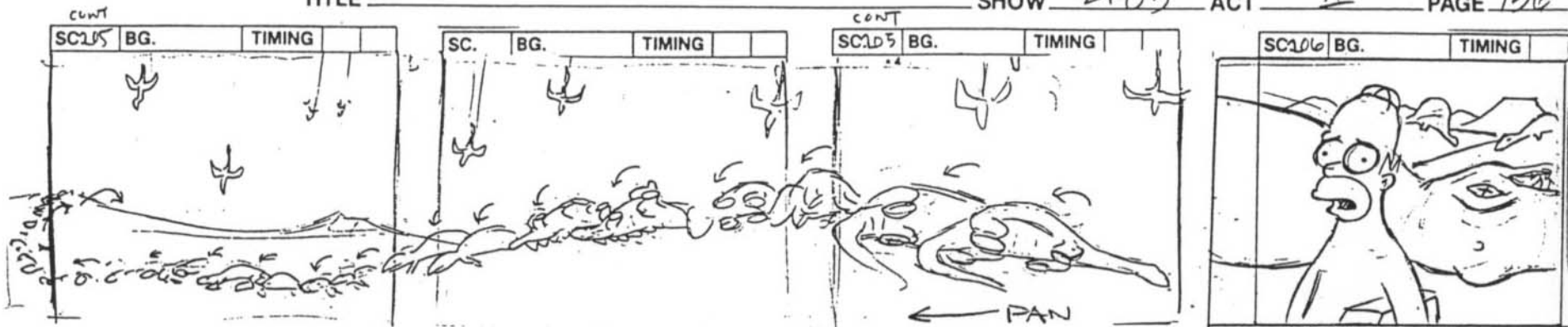

ACTION

HOMER'S PANORAMIC VIEW

of dinosaurs all over the landscape, SNEEZING and dying, one by one in rapid succession like dominoes.

HOLD ON BG - O.S. SNEEZE

A PTERODACTYL FALLS INTO SC,

TRANS.

A chair reaction starts.

DIAL

HOMER

(QUIET) This is gonna cost me.

TRANS.

NOTES

FILM ROMAN

THE SIMPSONS

TITLE _____

SHOW 2E03 A

II

157

SC. BG. TIMING

SC. BG. TIMING

SC. 157 BG. TIMING

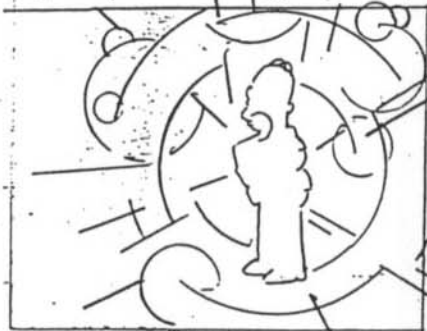
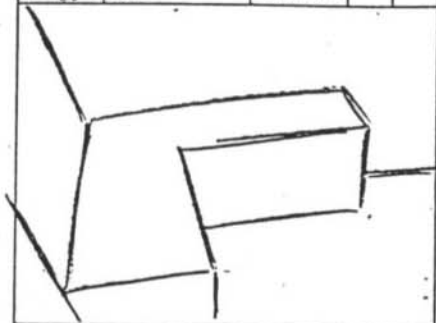
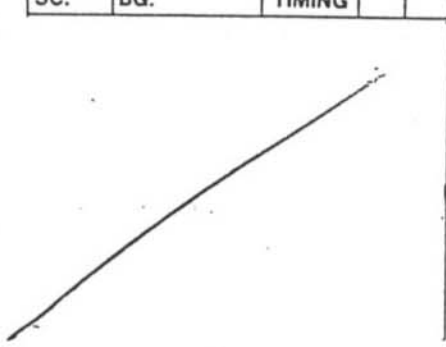
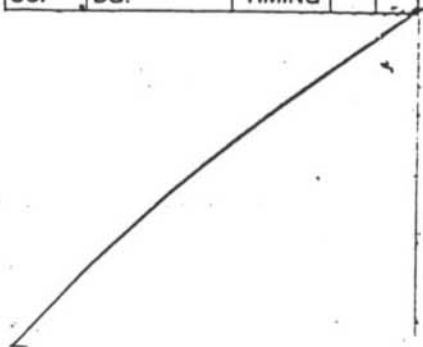

ACTIC

INT. BASEMENT -
HOLD ON BG

RE-USE ANIMATION

TRANS.

DIAL

TRANS.

NOTES

FILM ROMAN

THE SIMPSONS

TITLE _____ SHOW 203 ACT II PAGE 158

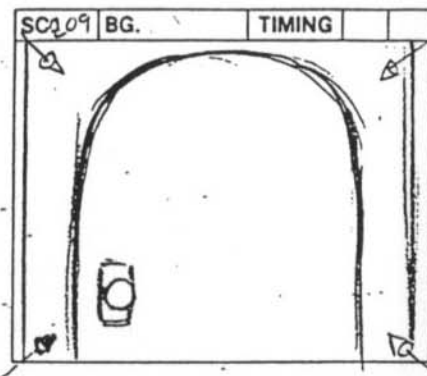
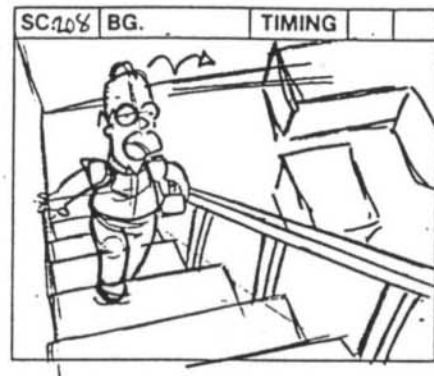
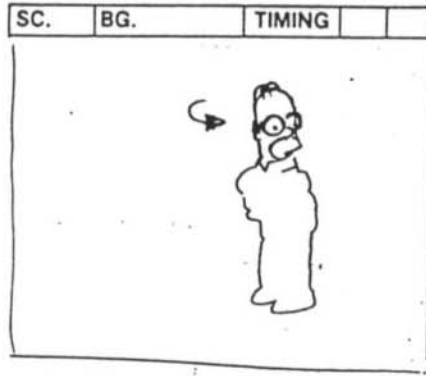
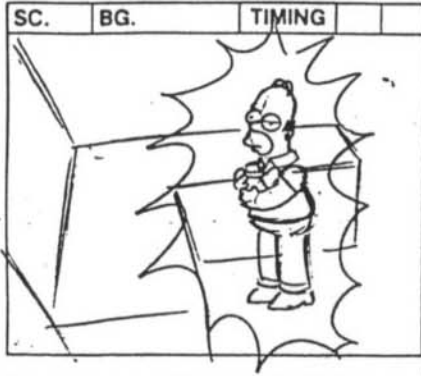

ACTION

RE-USE ANIMATION

TRACK IN

TRANS.

DIAL

TRANS.

NOTES

FILM ROMAN

THE SIMPSONS

SHOW 2F03 ACT II PAGE 199

TITLE _____

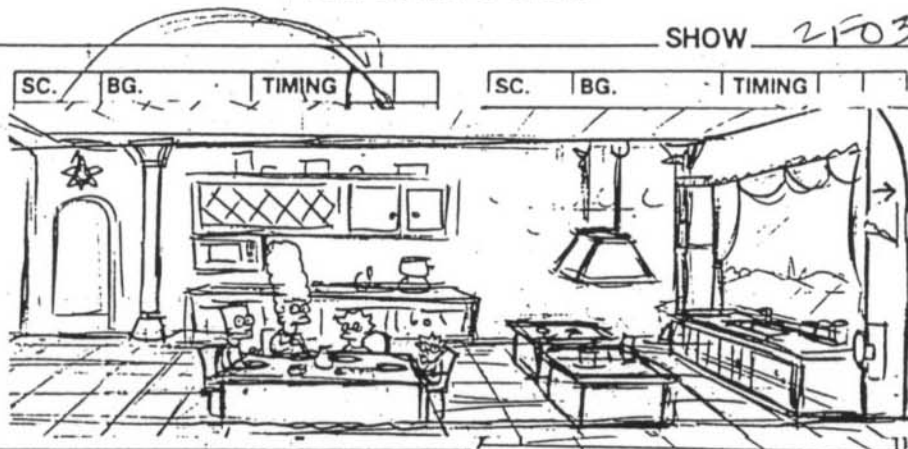
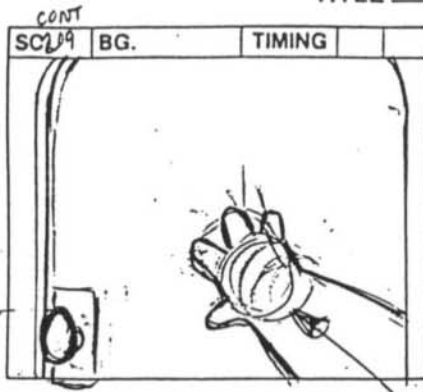

ACTION

RC-USE

INT. KITCHEN - MOMENTS LATER

The kitchen is now luxurious and beautiful. Marge and the kids, looking well-dressed and wonderful, sit eating a huge repast. The house looks like a mansion.

DOOR SWINGS O.S

Homer enters.

TRANS.

DIAL

||

HOMER

(ANNOYED GRUNT)

TRANS.

NOTES

FILM ROMAN

THE SIMPSONS

TITLE _____

SHOW 2K03

ACT II

PAGE 160

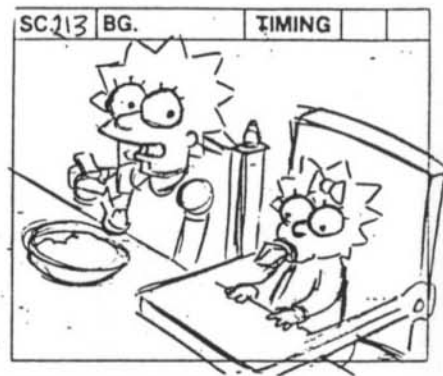
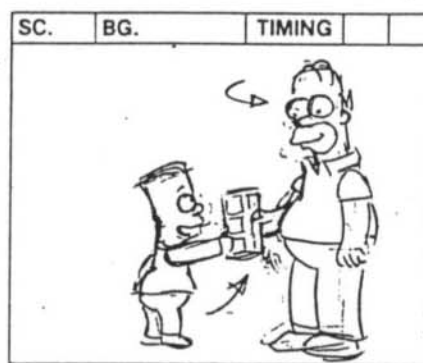
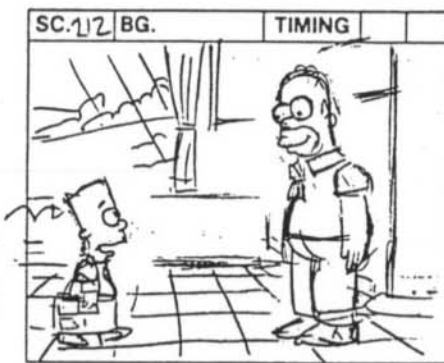
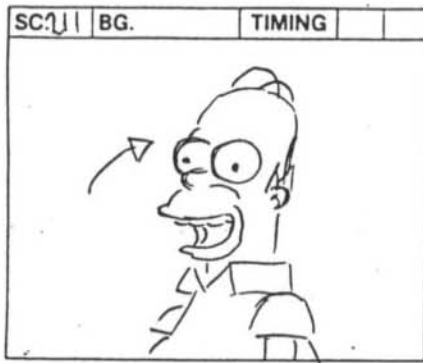

ACTION

He hands him a crisp newspaper.

TRANS.

DIAL

I mean, Heeeyy.

BART

(VERY POLITE) Good morning, dad. I ironed the funnies, just the way you like.

LISA

Are we taking the new Lexus to Aunt Patty and Selma's funeral today?

TRANS.

NOTES

FILM ROMAN

THE SIMPSONS

TITLE _____ SHOW 2403 ACT II PAGE 161

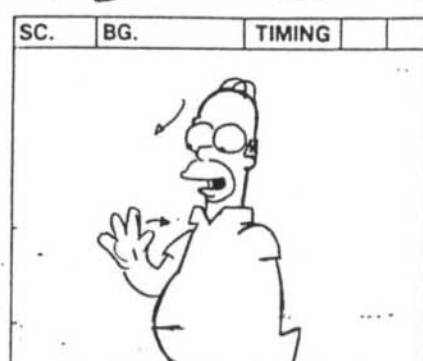
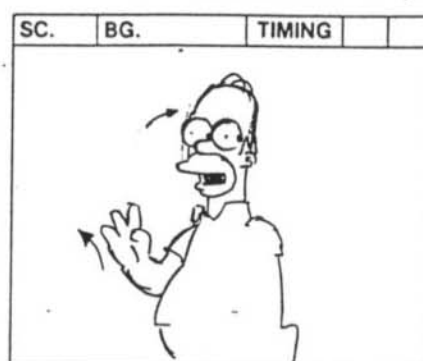
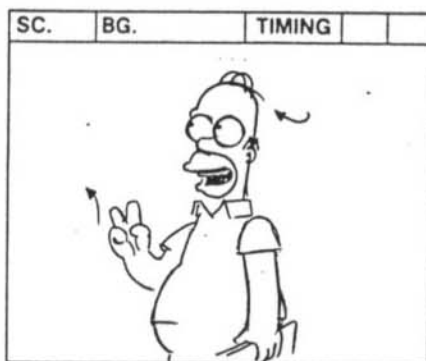
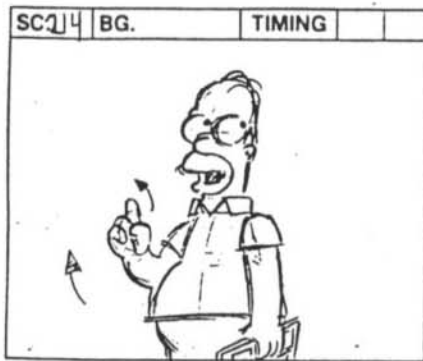

ACTION

SLOW TRUCK IN



TRANS.

DIAL

HOMER
(TO HIMSELF) Hmm. Fabulous house.
Well behaved kids.

Sister-in-law
dead. Luxury sedan.

TRANS.

NOTES

FILM ROMAN

THE SIMPSONS

TITLE _____ SHOW 2F03 ACT II PAGE 162

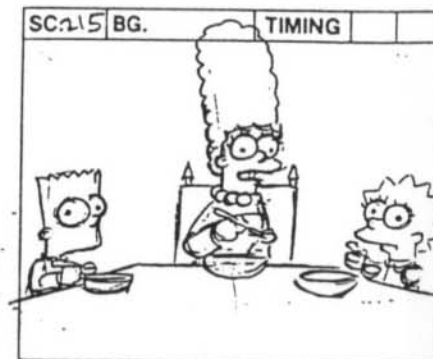
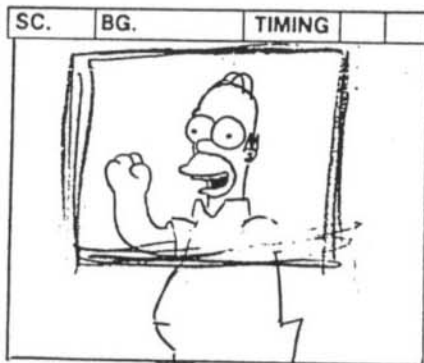
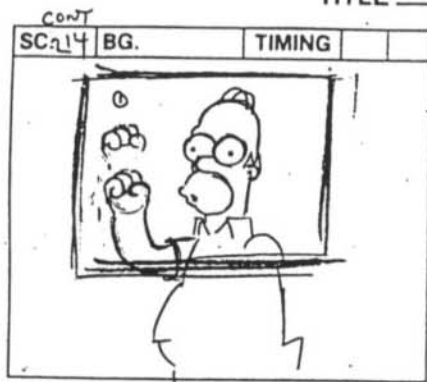

ACTION

HOMER SITS DOWN

TRANS.

DIAL

Woo hoo! I hit the jackpot.

(ALoud) Marge, dear.

Would you kindly pass me a donut?

MARGE

(PUZZLED) "Donut?" What's a donut?

TRANS.

NOTES

FILM ROMAN

THE SIMPSONS

TITLE _____

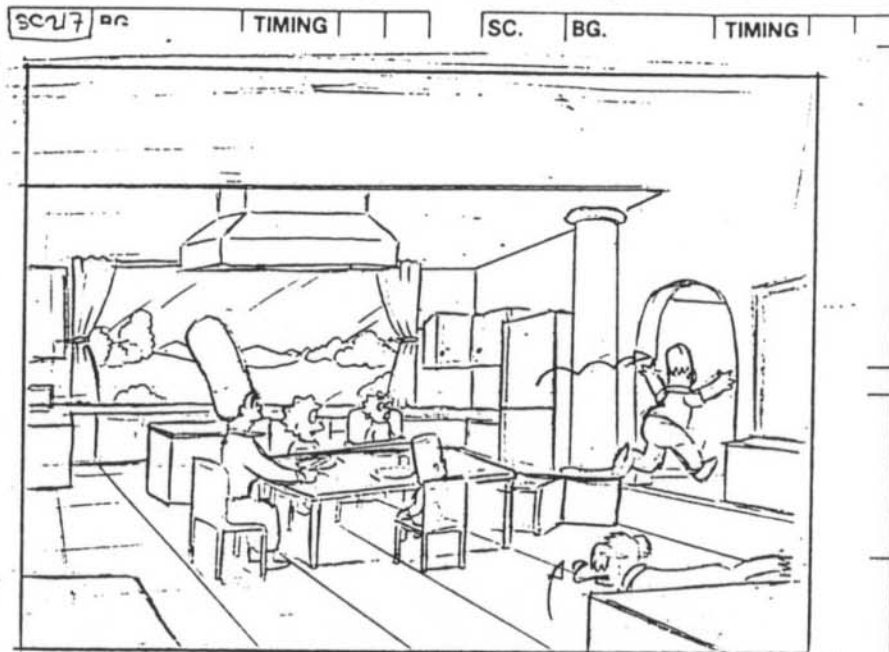
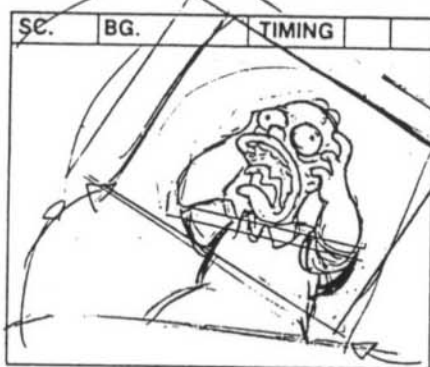
SHOW 2F03ACT IIPAGE 163

ACTION

TRANS.

DIAL

TRANS.

NOTES

He runs back into the basement and SLAMS the door.

HOMER

(SCREAMS AND SCREAMS)

FILM ROMAN

THE SIMPSONS

TITLE _____

SHOW 2F03

ACT II

PAGE 164

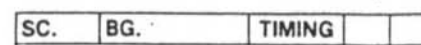
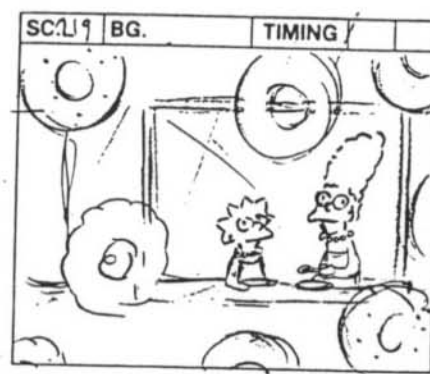
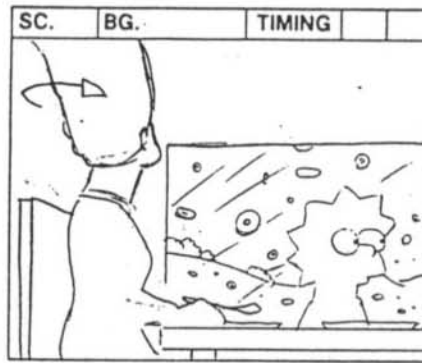
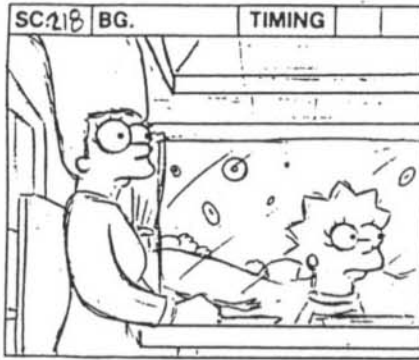

ACTION

looks out the window: donuts are falling from the sky. Marge

TRANS.

DIAL

MARGE

(CASUAL) Hmph. It's raining again.

TRANS.

NOTES

FILM ROMAN

THE SIMPSONS

TITLE _____ SHOW 203 ACT II PAGE 165

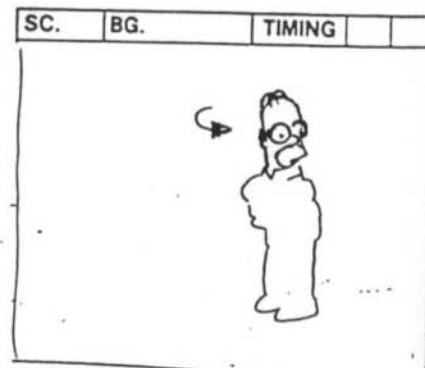
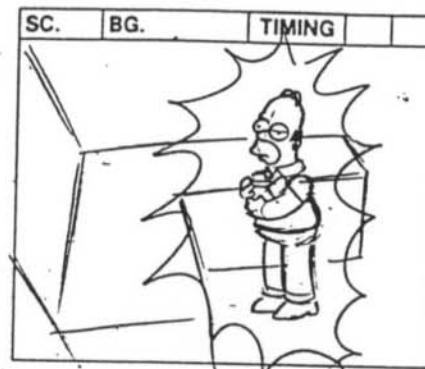
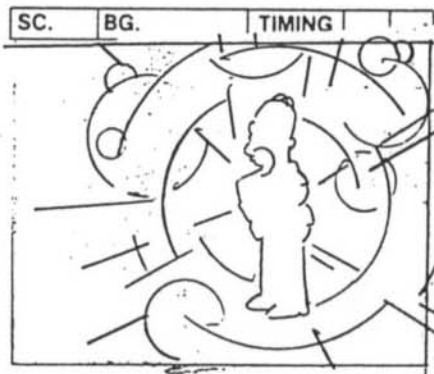
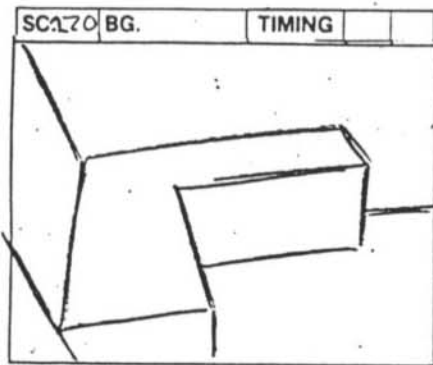

ACTION

INT. BASEMENT - MOMENTS LATER

There is a BLINDING ARC OF LIGHT, and then Homer pounds up the basement stairs

← RE-USE ANIMATION →

TRANS.

DIAL

TRANS.

NOTES

FILM ROMAN

THE SIMPSONS

TITLE _____

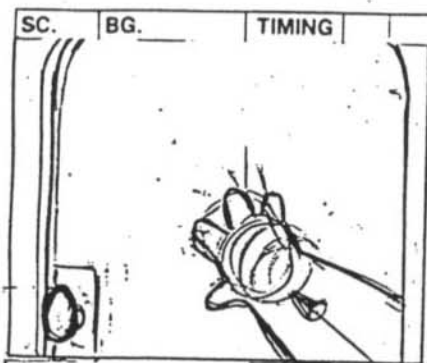
SHOW 2F03ACT IIPAGE 166

ACTIC

TRANS.

DIAL

TRANS.

NOTES

and throws open the door.

GROUNDKEEPER WILLIE is standing there.

GROUNDKEEPER WILLIE

You're still not in your own world,
Homer.

FILM ROMAN

THE SIMPSONS

TITLE _____ SHOW 2F03 ACT II PAGE 167

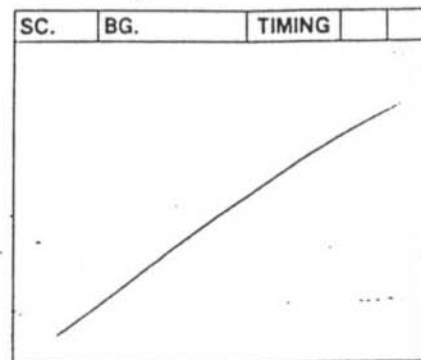
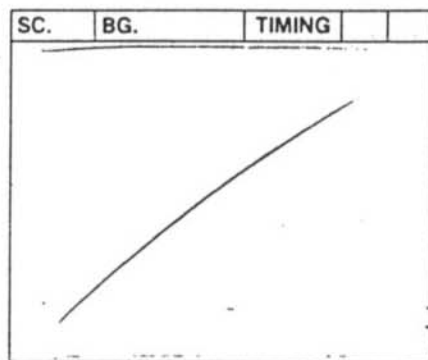
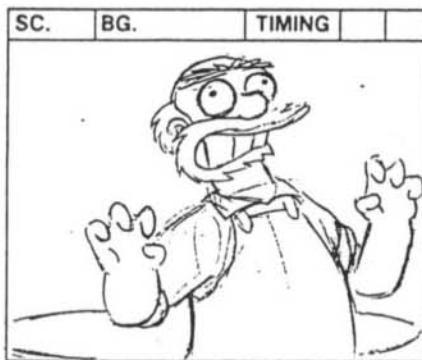

ACTION

TRANS.

DIAL

TRANS.

NOTES

But if you go back and do...
(SCREAMS)

FILM ROMAN

THE SIMPSONS

TITLE _____

SHOW 2F03

ACT II

PAGE 168

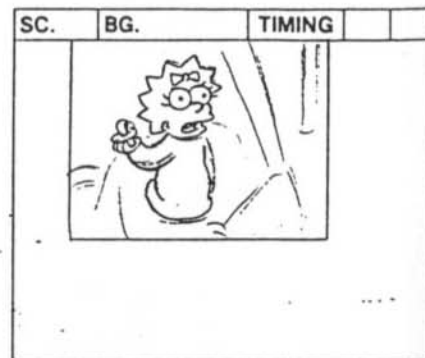
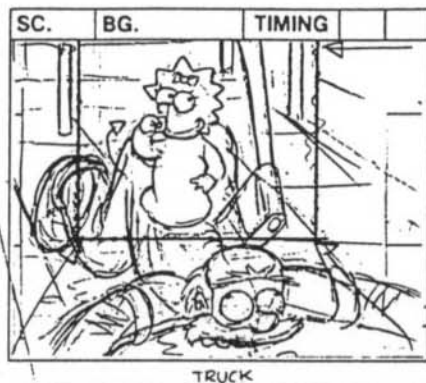
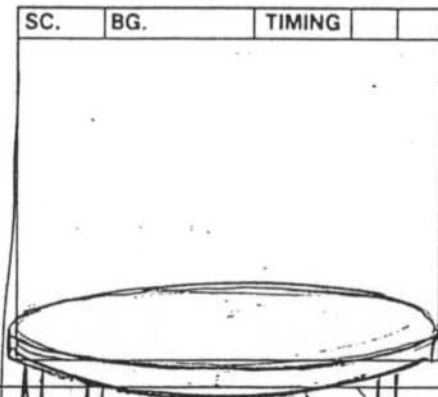

ACTION

O.S.

PAN DOWN
TO REVEAL

We see Maggie has just embedded an axe in Willie's back.

TRANS.

DIAL

MAGGIE

(JAMES EARL JONES VOICE) This is indeed a disturbing universe.

TRANS.



NOTES

FILM ROMAN

THE SIMPSONS

TITLE _____

SHOW 2F03

ACT II

PAGE 169

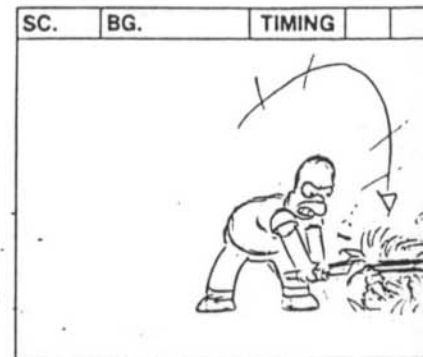
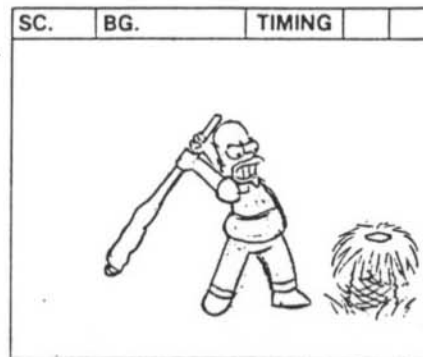
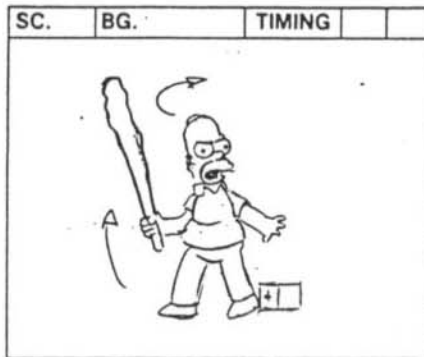
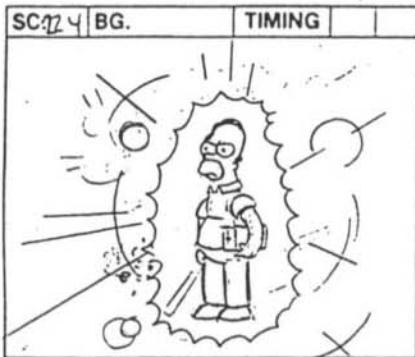

ACTION



EXT. SPRINGFIELD JUNGLE - 100 MILLION B.C. SCENE 8
An angry-looking Homer appears with a great big stick.

TRANS.

DIAL

HOMER
Don't touch anything?!!

(WILDLY) I'll... touch... whatever...

TRANS.

NOTES

FILM ROMAN

THE SIMPSONS

TITLE _____

SHOW 2F03

ACT II

PAGE 170

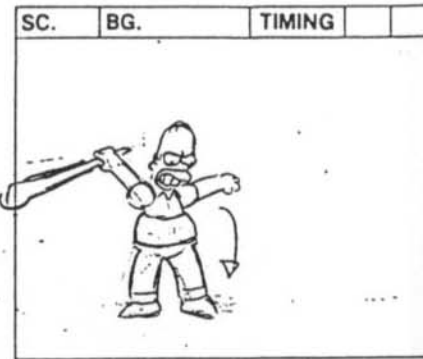
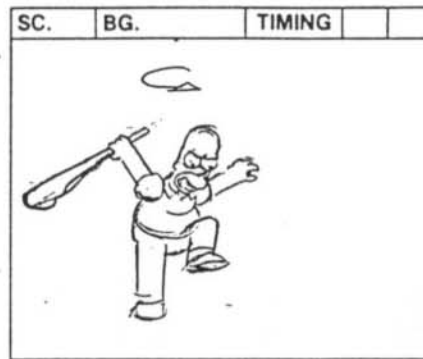
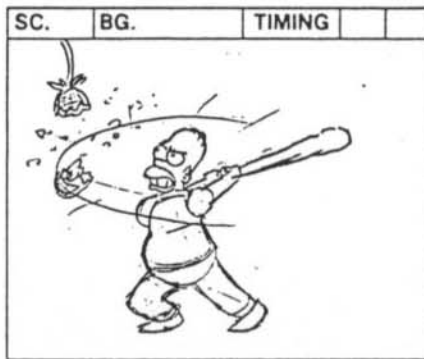
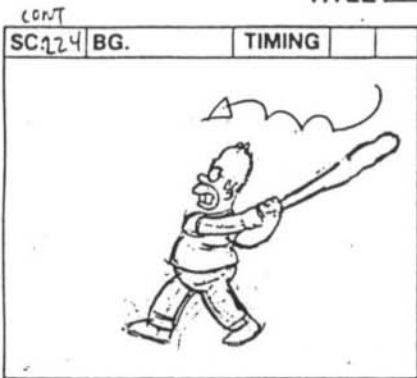

ACTION

He wildly **THRASHES** about **SMASHING** things, **BREAKING** every twig and **SQUASHING** every bug he can find.

TRANS.

DIAL

I... feel like!!

TRANS.

NOTES

FILM ROMAN

THE SIMPSONS

TITLE _____ SHOW 2F03 ACT II PAGE 171

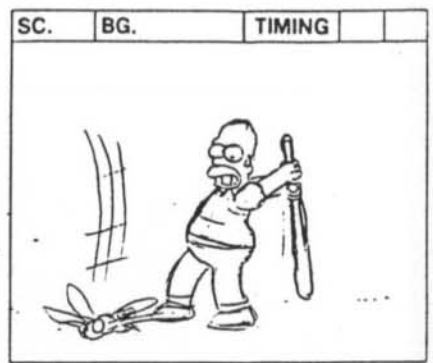
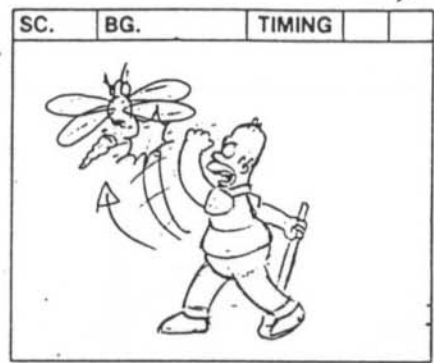
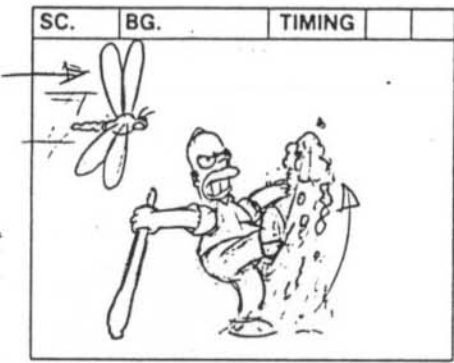
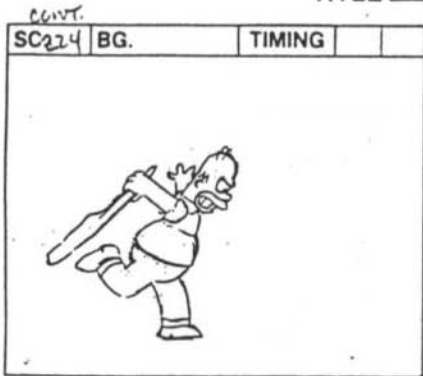

ACTION			
TRANS.			
DIAL	HOMER (CONT'D) (FRUSTRATED GRUNTS AND INSANE GIGGLES)		
TRANS.			
NOTES			

FILM ROMAN

THE SIMPSONS

TITLE _____

SHOW 2F03

ACT H

PAGE 172

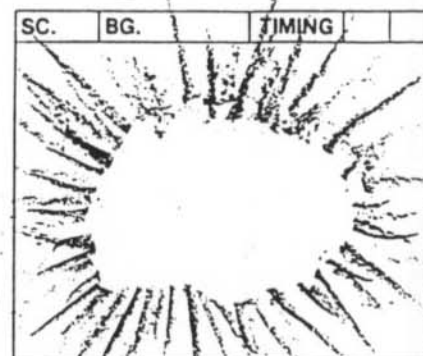
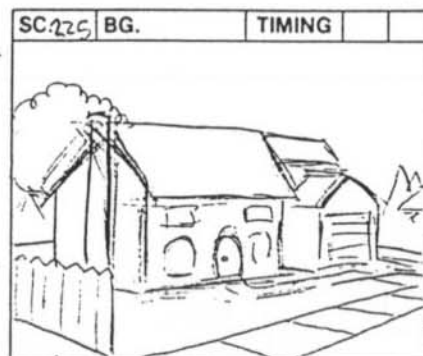
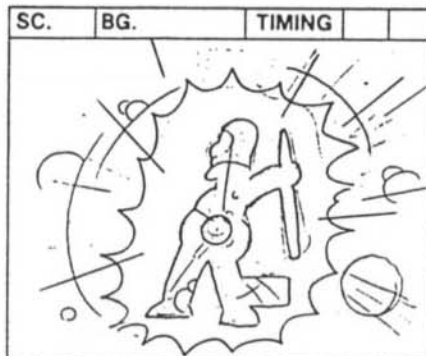
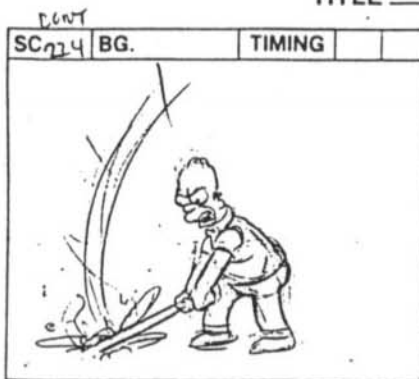

ACTION

He vanishes again.

EXT. SIMPSON HOUSE - DAY

TRANS.

DIAL

TRANS.

NOTES

FILM ROMAN

THE SIMPSONS

TITLE _____

SHOW 2F03 ACT II PAGE 173

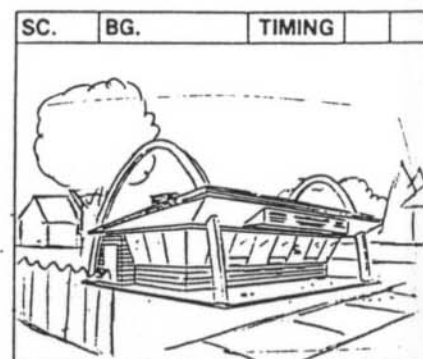
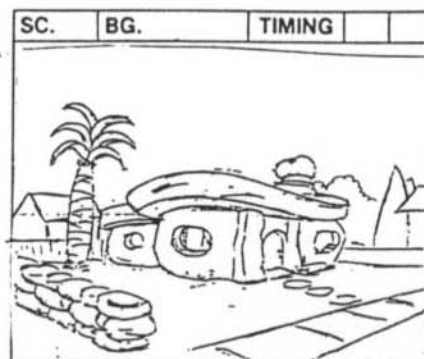
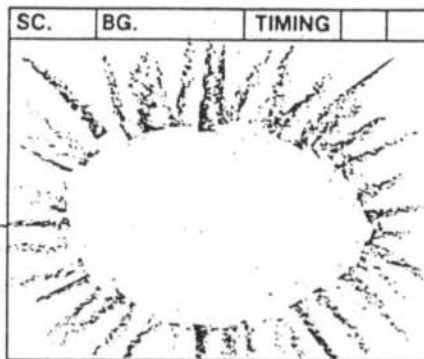
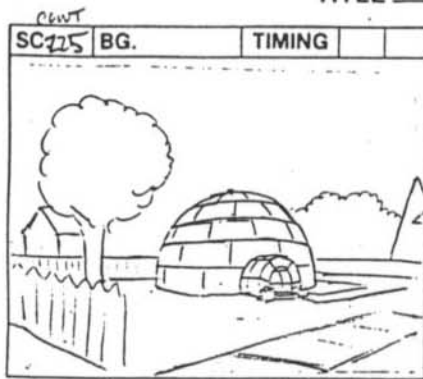

ACTION

In rapid succession (and in between flashes of light), the Simpson house turns into an igloo, the Flintstones' house, a 1950s McDonalds...



TRANS.

DIAL

TRANS.

NOTES

FILM ROMAN

THE SIMPSONS

TITLE _____

SHOW 2F03

ACT II

PAGE 174

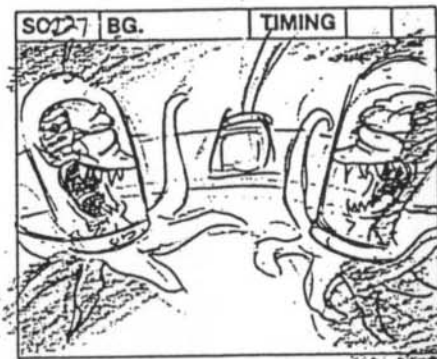
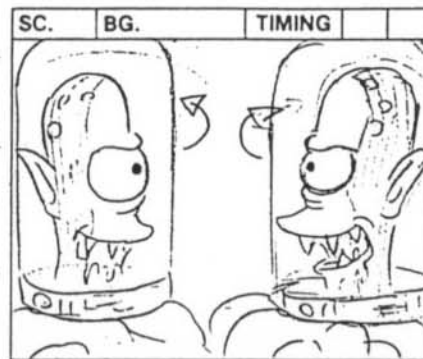
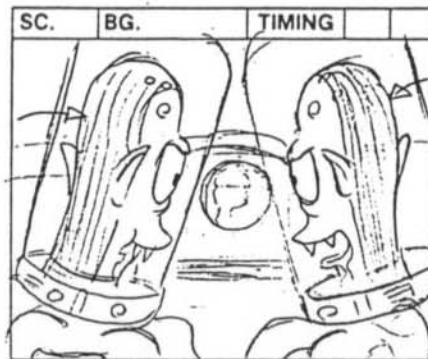
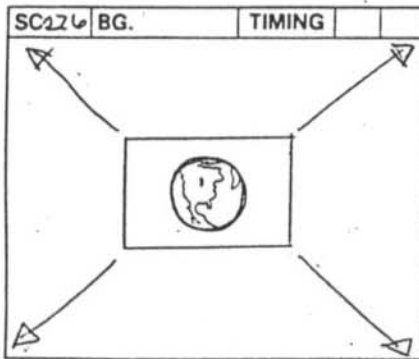

ACTION

PULL BACK to reveal KANG and KODOS in their spaceship.

TRANS.

*Possible from
cycle*

DIAL

KANG

Foolish time traveling earthling,
thinking his pathetic actions can alter
the universe. (They LAUGH)

TRANS.

NOTES

FILM ROMAN

THE SIMPSONS

TITLE _____

SHOW 2403

ACT II

PAGE 175

CONT

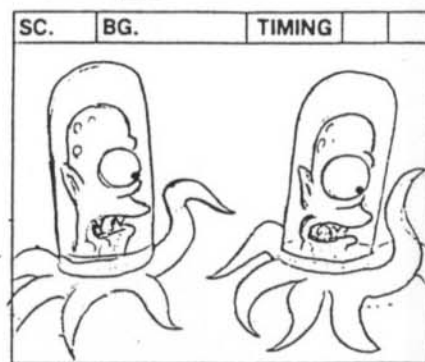
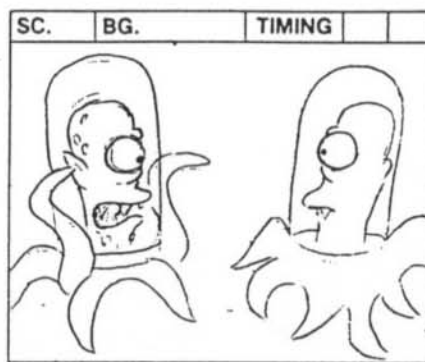
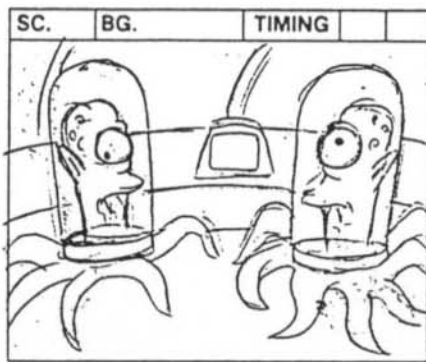
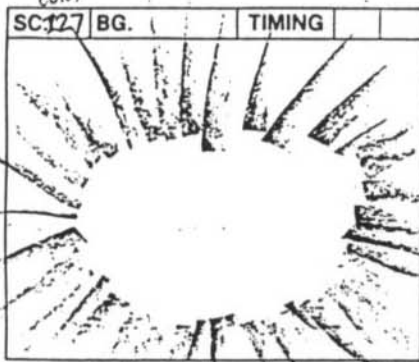

ACTION

There is our familiar FLASH OF LIGHT. Kang and Kodos are silent for a moment. Everything seems the same, then...

TRANS.

DIAL

KODOS
 GREAT (NOTICING) Great Andromeda's gas! You
 have an extra tentacle!

TRANS.

NOTES

FILM ROMAN

THE SIMPSONS

SHOW 2F03ACT IIPAGE 176

TITL F

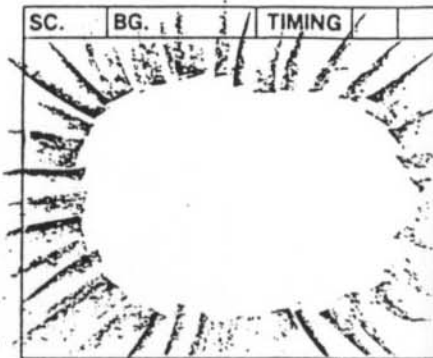
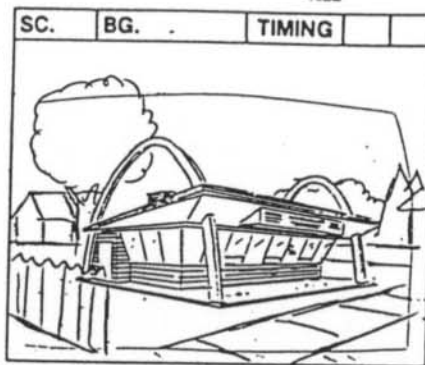
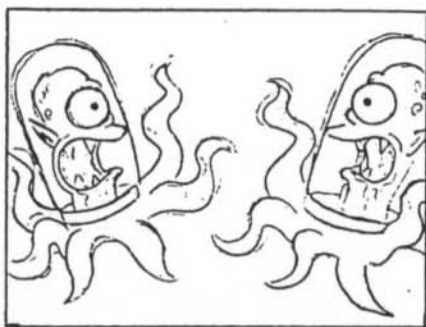
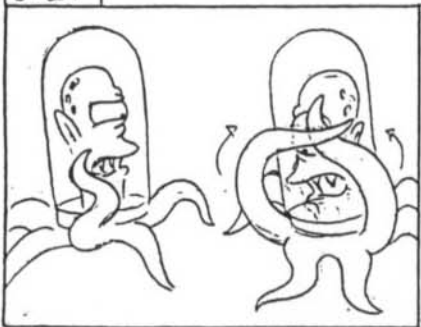
CONT
SC 227

ACTION

They both start SCREAMING for way too long.

EXT. SIMPSON HOUSE

TRANS.

DIAL

KANG

(GASP) I'm a horrible freak! Don't look at me!

TRANS.

NOTES

*Cycle
screams*

FILM ROMAN

THE SIMPSONS

TITLE _____

SHOW 2F03

ACT II

PAGE 177

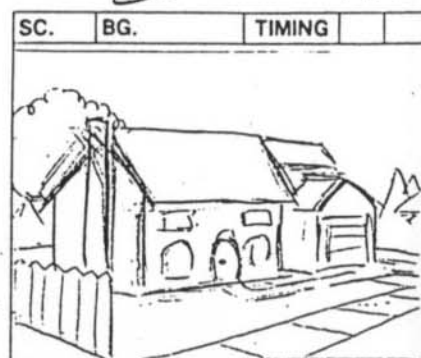
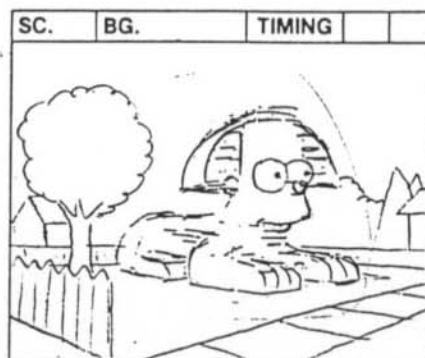
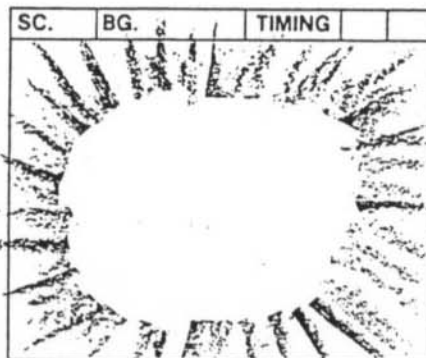
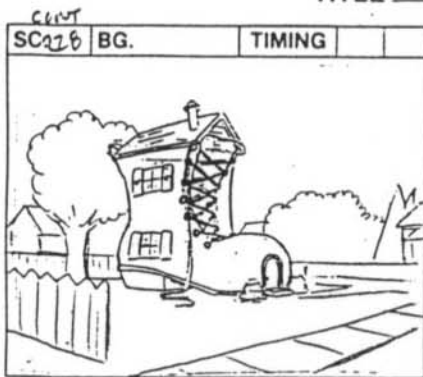

ACTION

as it changes back into a giant shoe ala the fairy tale, the Sphinx with Bart's head, and then finally returns to the Simpson house.

TRANS.

DIAL

TRANS.

NOTES

FILM ROMAN

THE SIMPSONS

TITLE _____

SHOW 2F03 A

II

PAGE 178

SC.	BG.	TIMING
-----	-----	--------

SC.	BG.	TIMING
-----	-----	--------

SC129	BG.	TIMING
-------	-----	--------

TIMING

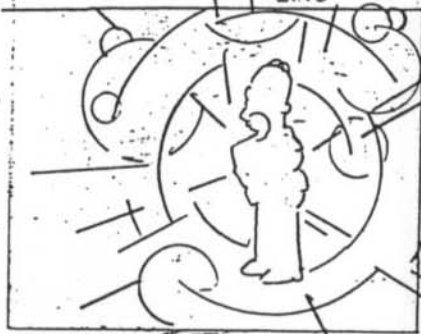
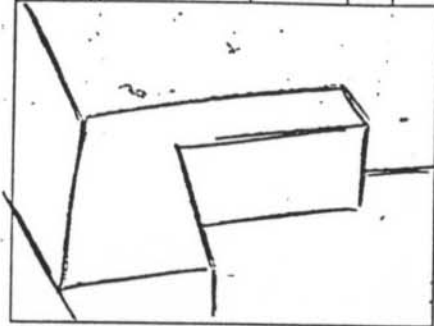
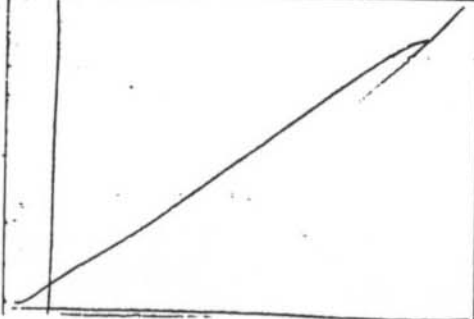

ACTIC

INT. BASEMENT -
HOLD ON BG

RE-USE ANIMATION

TRANS.

DIAL

TRANS.

NOTES

FILM ROMAN

THE SIMPSONS

2503 ACT II PAGE 179

TITLE _____

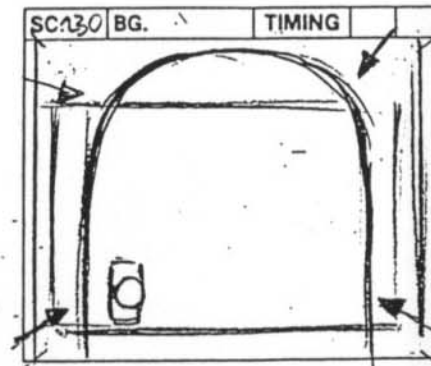
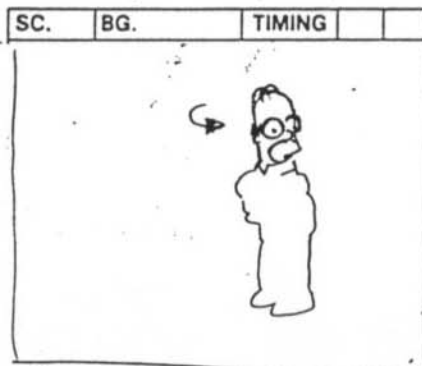
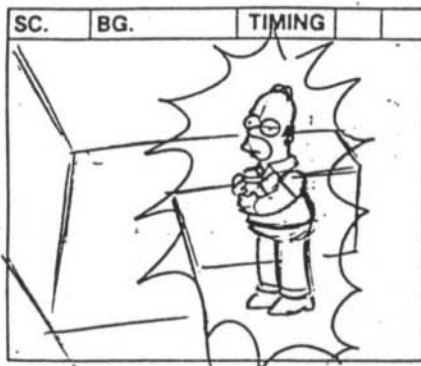

ACTION

INT. BASEMENT - SECONDS LATER

Homer reappears and steps to the basement door.

TRUCK IN AND STOP

TRANS.

DIAL

TRANS.

NOTES

FILM ROMAN

THE SIMPSONS

TITLE _____

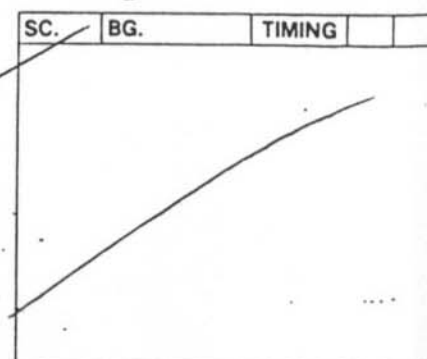
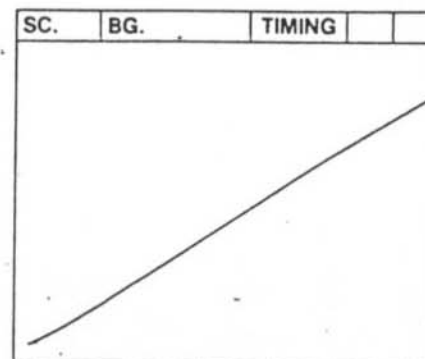
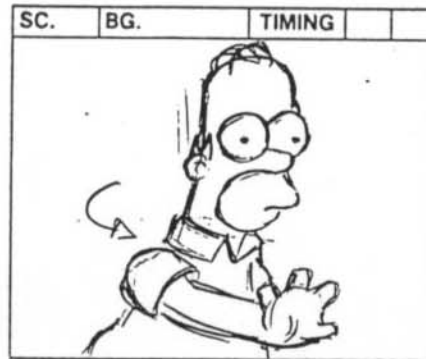
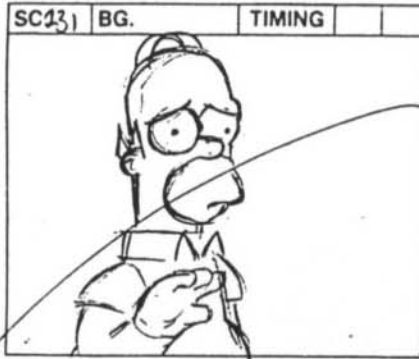
SHOW 2F03ACT IIPAGE 180

ACTION

HESITATES

After
hesitating, he very slowly and nervously opens the door a
crack and peeps out.

TRANS.

DIAL

TRANS.

NOTES

FILM ROMAN

THE SIMPSONS

TITLE _____

SHOW 2F03 ACT 2II PAGE 181

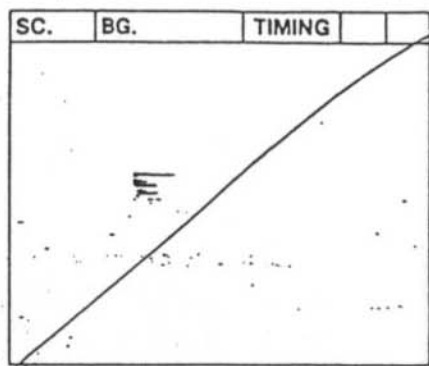
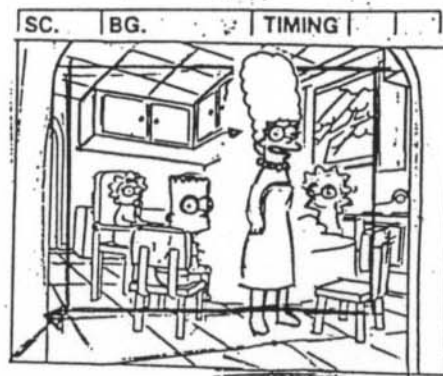
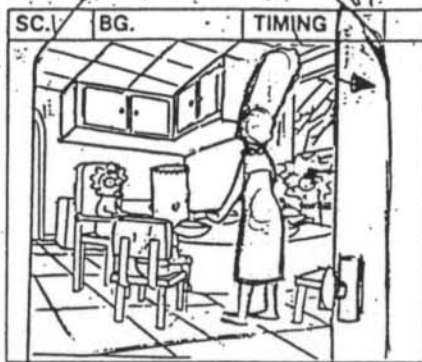
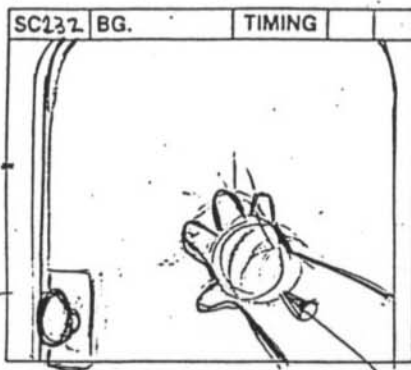

ACTION

INT. KITCHEN - CONTINUOUS

The kitchen and the family all look perfectly normal.

< >
R
swings O.S

TRANS.

DIAL

MARGE

Morning, dear.

TRANS.

NOTES

FILM ROMAN

THE SIMPSONS

TITLE _____

ACT _____ PAGE 182

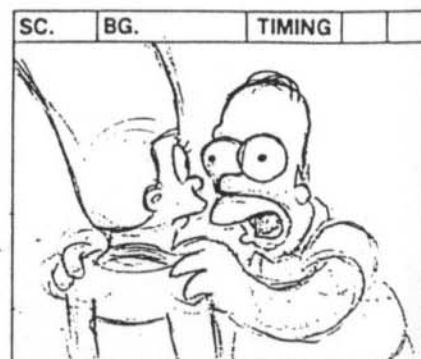
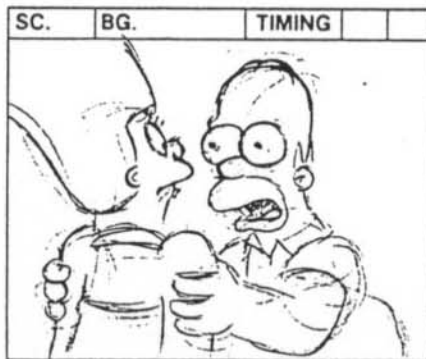
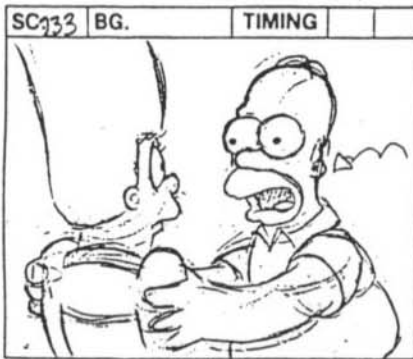

ACTION

TRANS.

DIAL

TRANS.

NOTES

	<p>HOMER</p> <p>WHAT'S... (WILDLY) What's my name?! What color... is the sky?!</p>	<p>What of donuts? WHAT?!</p> <p>(SHAKING MARGE) For the love of God, tell meeee!!!</p>	

FILM ROMAN

THE SIMPSONS

TITLE _____ SHOW _____ ACT _____ PAGE 183

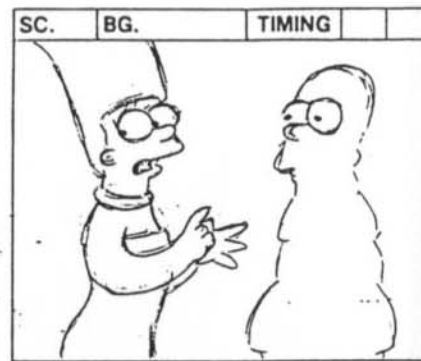
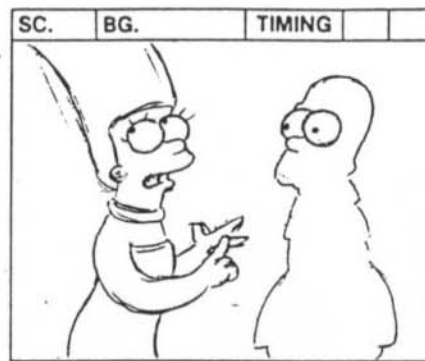
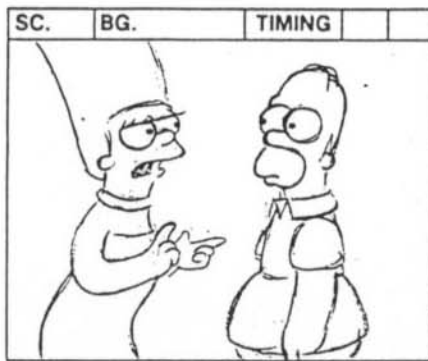
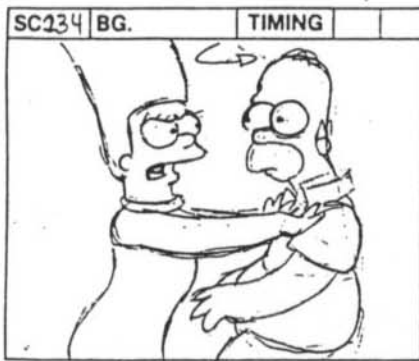

ACTION

TRANS.

DIAL

TRANS.

NOTES

MARGE
Homer! The sky is blue.

Donuts are
plentiful. Friday is TGIF night on
ABC.

FILM ROMAN

THE SIMPSONS

CONT

TITLE _____

SHOW _____

ACT _____

PAGE 184

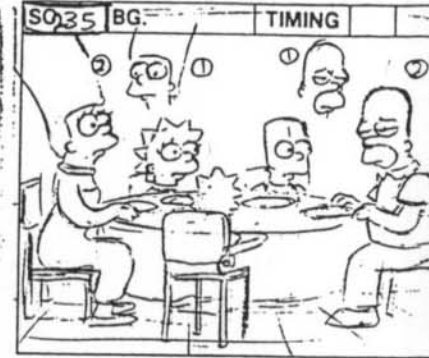
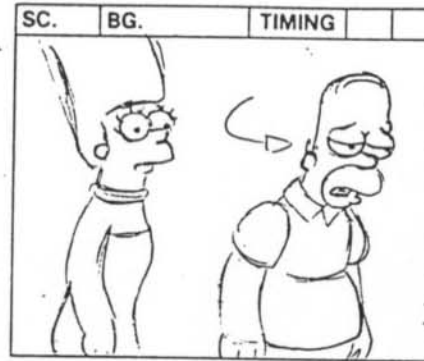
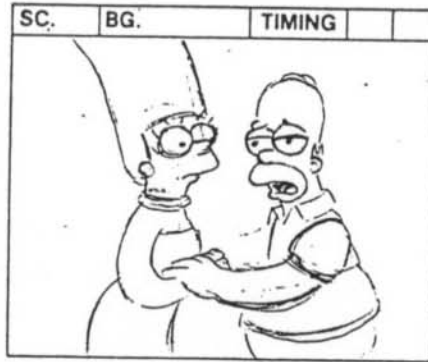
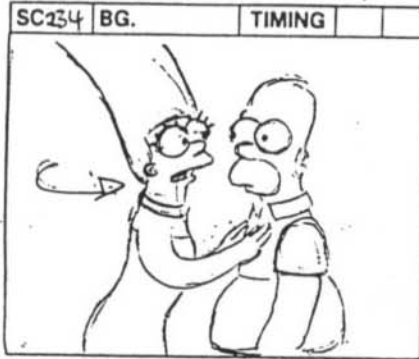

ACTIC

Relieved

Homer sags to the table, exhausted.

TRANS.

DIAL

What's gotten into you?

HOMER

Nothing. Nothing at all. Let's just eat.

TRANS.

NOTES

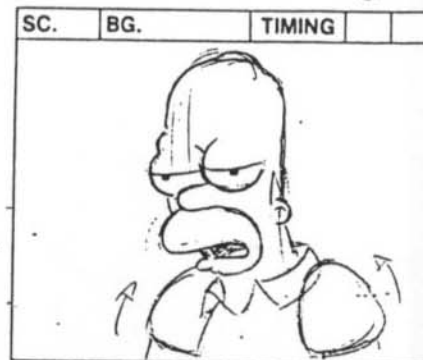
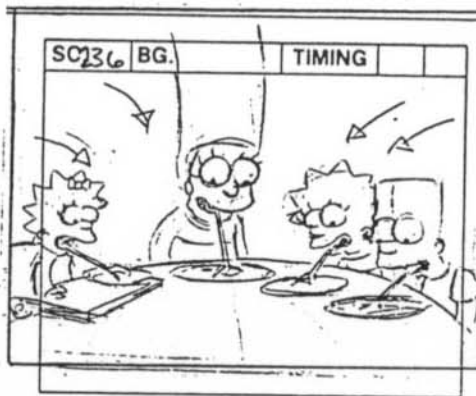

ACTIO.

Marge, Bart, Lisa and Maggie open their mouths and long, forked snake-tongues emerge, which grab their food and snap back into their mouths, like a frog. Homer watches this in horror for a second, then:

TRANS.

DIAL

TRANS.

NOTES

HOMER (CONT'D)
 (SHRUGS, TO HIMSELF) Eh. Close
 enough.

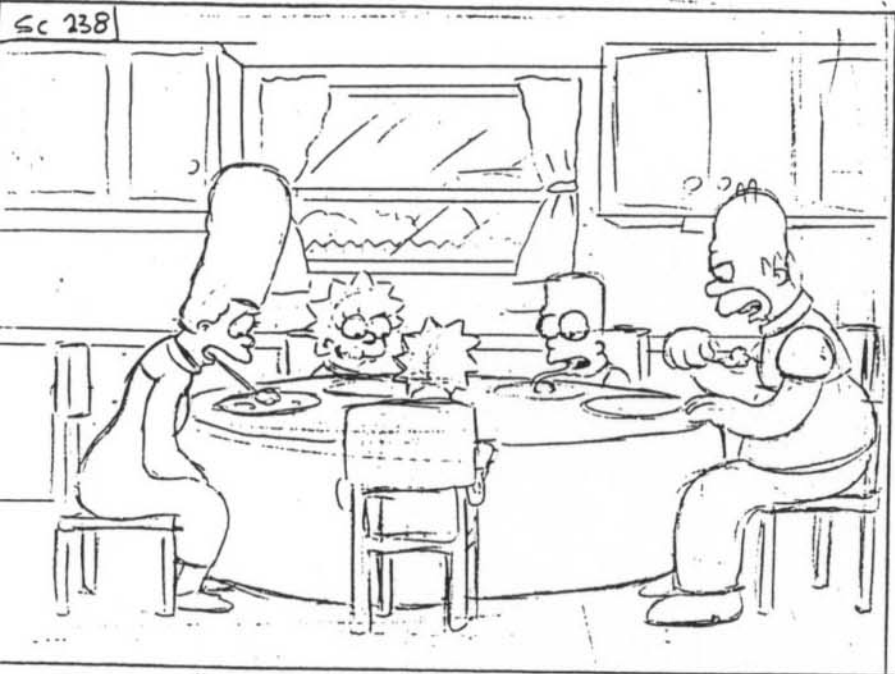

FADE OUT:

THE END

He starts eating with the rest of them.

THE SIMPSONS

EPIISODE #	2F03
EPIISODE TITLE	"TREEHOUSE OF HORROR V"
<h2>ACT III</h2>	
ROUGH DRAFT	5/6/94
REVISED	
FINAL	

FILM ROMAN

THE SIMPSONS

TITLE TREEHOUSE OF HORROR V

SHOW 2F03

ACT III

PAGE 187

SC.	BG.	TIMING
<h2>NIGHTMARE CAFETERIA</h2> <p>DIRECTED BY: JIM REARDON STORYBOARD BY: MARTIN ARCHER</p>		

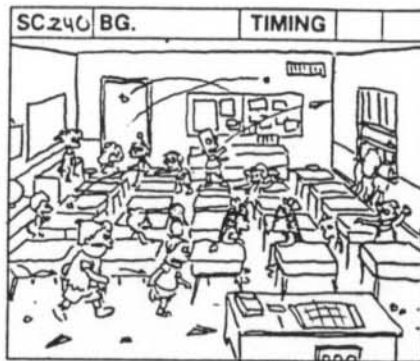
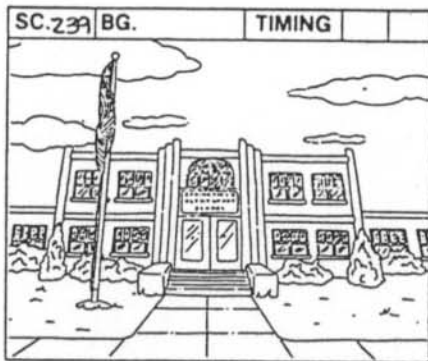

ACTION

NIGHTMARE CAFETERIA

FADE IN:

by

EXT. SPRINGFIELD ELEMENTARY SCHOOL - ESTABLISHING

David S. Cohen

INT. MRS. KRABAPPEL'S CLASS

She's not there yet. The KIDS are running rampant.

TRANS.



DIAL

KID RUNS TOWARD

SC

TRANS.

BART

(WHISTLES)

NOTES

FILM ROMAN

THE SIMPSONS

TITLE _____

SHOW 2F03

ACT III

PAGE 188

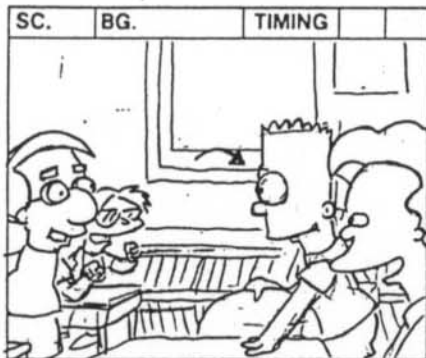

ACTION

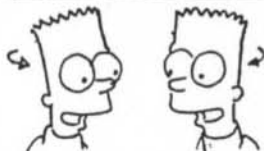

ADJUST

CUT TO EXT. HALLWAY

EXT. HALLWAY - SIMULTANEOUS

MRS. KRABAPPEL approaches. Through the door, we hear desk SCRAPING sounds.

TRANS.

DIAL

Hey everybody! Let's all turn our desks backwards before Mrs. Krabappel shows up!

CLASS

(AD LIBBING) Yeah/ Cool/ Great idea/ etc.

TRANS.

NOTES

FILM ROMAN

THE SIMPSONS

TITLE _____

SHOW 2FO3

ACT III

PAGE 189

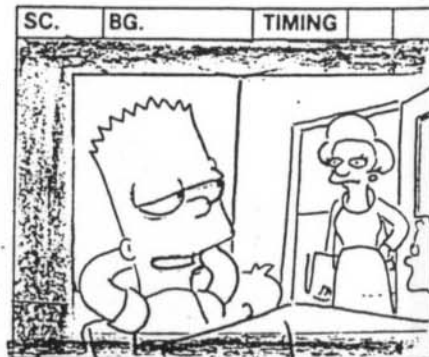
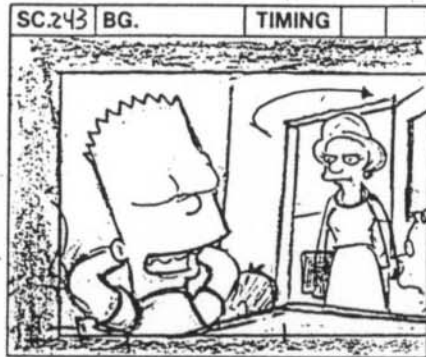

ACTIC

MRS. KRABAPPEL'S POV

Every student sits facing forward, as usual, except Bart.
He lounges backward, smugly facing the rear wall.

TRANS.

DIAL

BART

(COCKY LAUGH, ...)

TRANS.

NOTES

FILM ROMAN

THE SIMPSONS

SHOW 2F03 ACT III PAGE 190

TITLE _____

CONT

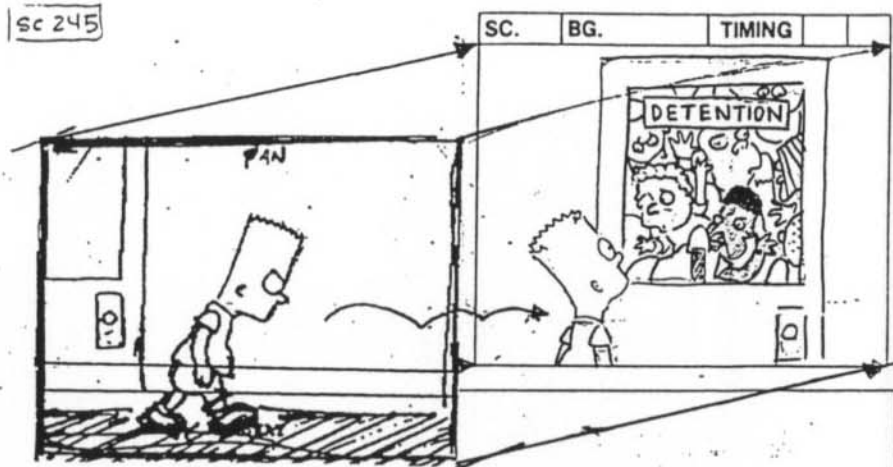
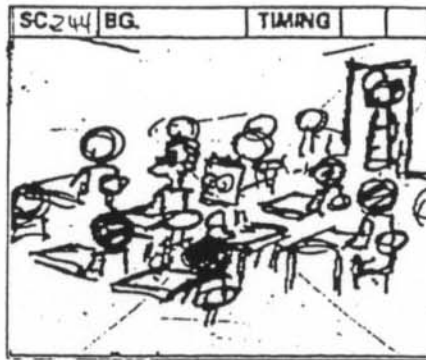
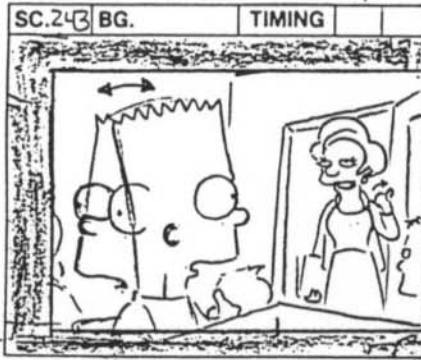

ACTION

TRANS.

DIAL

TRANS.

NOTES

INT. HALLWAY

Bart walks up to a door marked "DETENTION ROOM." We see the room is literally jam packed to the rafters. Many faces are pressed up against and peering out forlornly through the glass of the door.

BART

... THEN REALIZING) Eh?

MRS. KRABAPPEL

(ROLLS EYES) Alright, backwards boy.
Back your butt down to detention.

FILM ROMAN

THE SIMPSONS

TITLE _____

SHOW 260 3

ACT III

PAGE 191

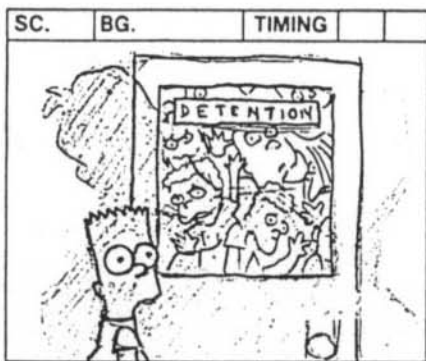
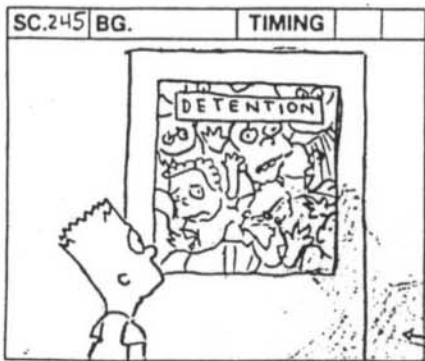

ACTION

Skinner **SHACKS** a rod against his palm.



TRANS.

* NOTE - KIDS PRESSED AGAINST GLASS.

DIAL

PRINCIPAL SKINNER

Over here, Simpson! The detention room is dangerously overcrowded, so you'll be serving your time in the cafeteria.

KID BEHIND GLASS

(WEAK VOICE) Oxygen running out...

TRANS.

NOTES

FILM ROMAN

THE SIMPSONS

TITLE _____

SHOW 2F03

ACT III

PAGE 192

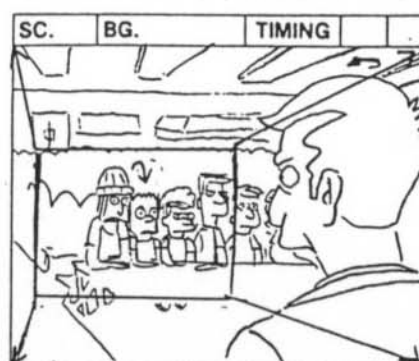
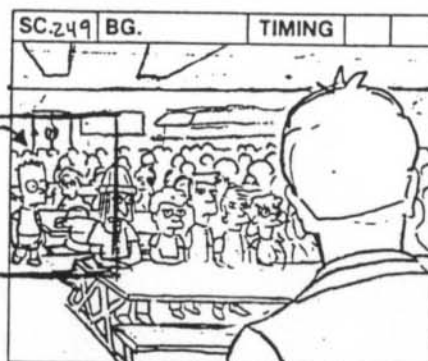

ACTION

INT. CAFETERIA

Bart is squeezed into a crowded table with other juvenile delinquents. Skinner looks on disgustedly.



TRANS.



TIGHTER SQUEEZE

DIAL

PRINCIPAL SKINNER

(CURT) Yes, you should have thought of that before you made that paper airplane.

PRINCIPAL SKINNER

This overcrowding in detention is becoming critical. It's a powder keg waiting to go off in an explosion of unacceptable behavior.

TRANS.

NOTES

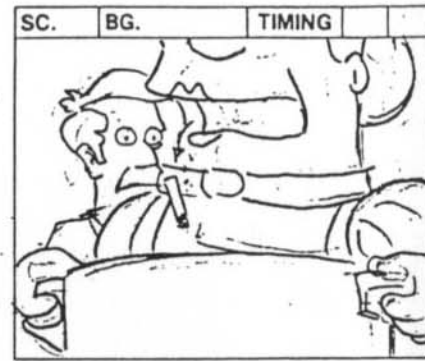
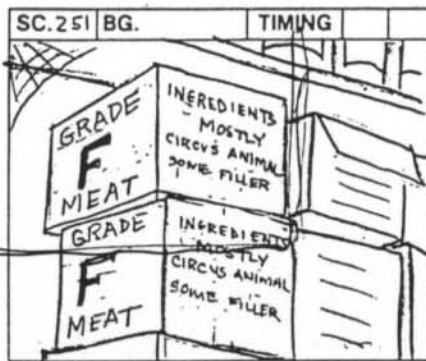

ACTION TRANS. DIAL TRANS. NOTES	<p>PULL-OUT AS DORIS ENTERS.</p> <p>LUNCHLADY DORIS walks by carrying an enormous kettle of soup.</p>	<p>INT. CAFETERIA STOREROOM</p> <p>We see several stacked boxes labelled "Grade F Meat - mostly circus animals, some filler."</p> <p><i>Re-field add color</i></p>	<p>BACK TO SCENE</p>	
	<p>LUNCHLADY DORIS</p> <p>Don't bitch to me, bossman. Thanks to the latest budget cuts, I'm down to using grade F meat.</p>	<p>(PU)</p>	<p>PRINCIPAL SKINNER</p> <p>Wouldn't it be wonderful if there were some sort of common solution to both our problems?</p>	<p>LUNCHLADY DORIS</p> <p>That would be great!</p>

FILM ROMAN

THE SIMPSONS

cont'd

TITLE _____

SHOW 2F03

ACT III

PAGE 194

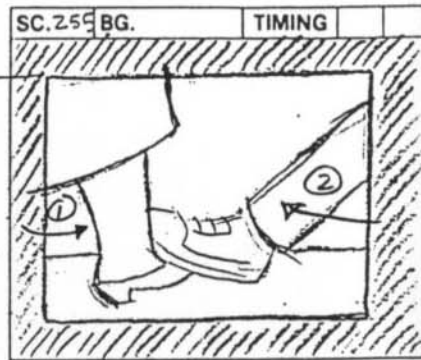
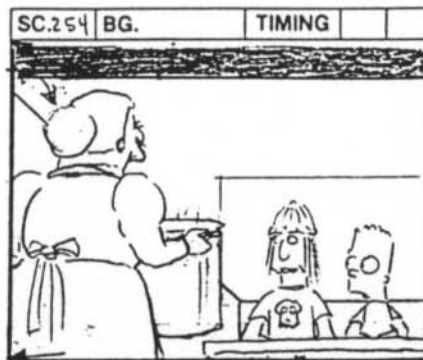
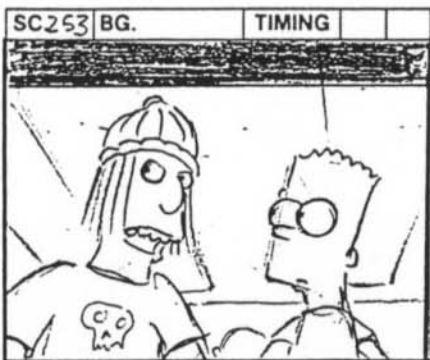
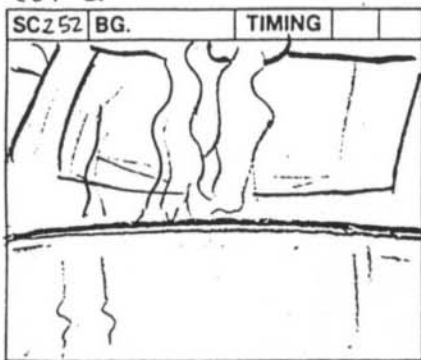

PULL-OUT.

ACTION

DORIS WALKS INTO CAM.

As Lunchlady Doris walks by,

Jimbo sticks out his foot.

TRANS.

DIAL

JIMBO
Hey, Bart, watch this.

TRANS.

NOTES

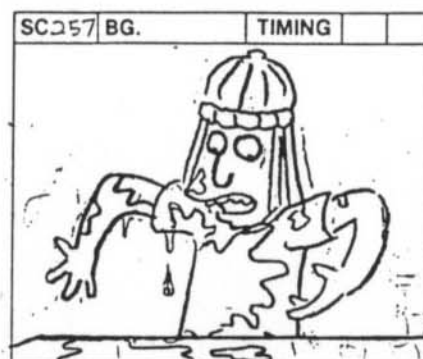
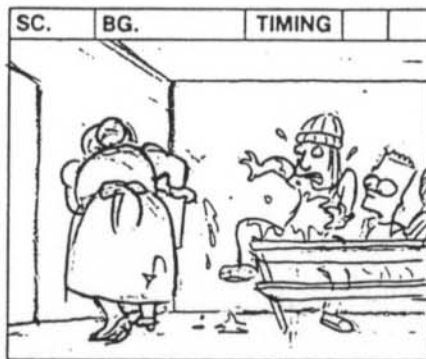
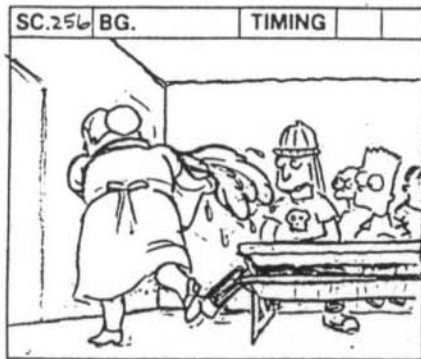

ACTION

Lunchlady Doris trips, accidentally spilling soup all over Jimbo.

TRANS.

DIAL

LUNCHLADY DORIS
Drats.

JIMBO (CONT'D)

Oh no! My favorite outfit!

TRANS.

NOTES

FILM ROMAN

THE SIMPSONS

TITLE _____

SHOW 2F03

ACT III

PAGE 196

CONT

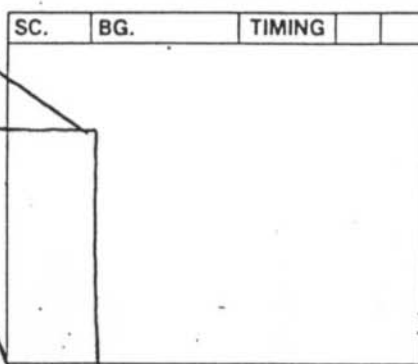
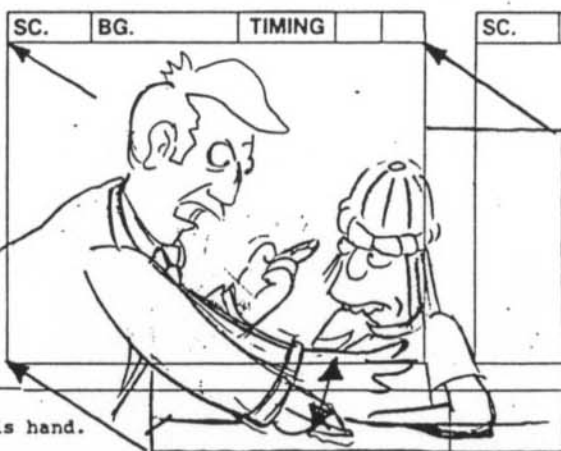
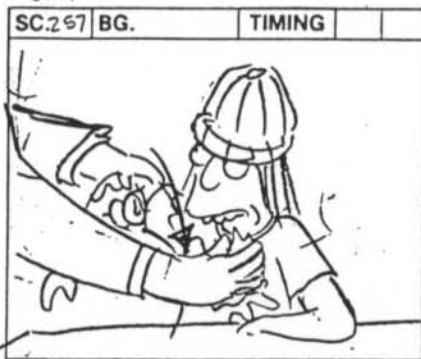

ACTION

Skinner begins wiping Jimbo off with his hand.

Skinner absently licks his finger.

TRANS.

*wider
two-shot*

DIAL

PRINCIPAL SKINNER

Jimbo, this is by far the worst...

TRANS.

NOTES

FILM ROMAN

THE SIMPSONS

SHOW 2F03 ACT III PAGE 197

TITLE _____

CONT

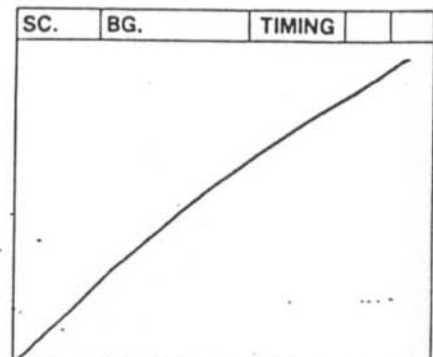
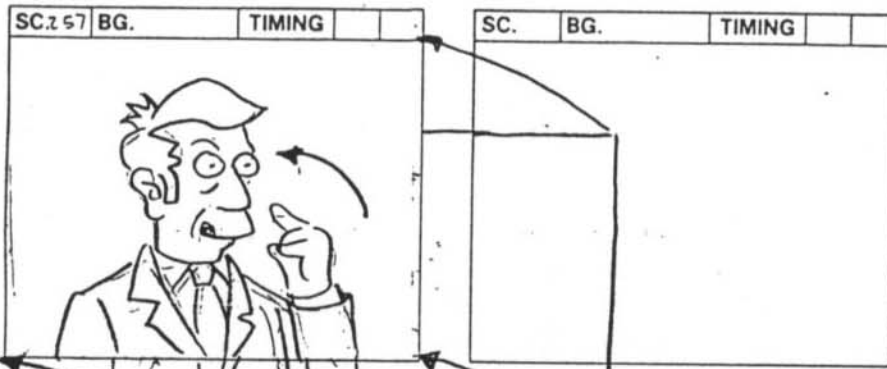

ACTION

Cut To:

He scoops several more finger-fuls.

TRANS.

WIPES BARE ARM

DIAL

PRINCIPAL SKINNER (CONT'D)

(SUDDEN SURPRISED SAVOR) Hmmmm.

TRANS.

NOTES

FILM ROMAN

THE SIMPSONS

TITLE _____

SHOW 2F08

ACT III

PAGE 198

	SC. 258	BG.	TIMING		SC.	BG.	TIMING		SC.	BG.	TIMING		SC.	BG.	TIMING	
ACTION																
TRANS.																
DIAL																
TRANS.																
NOTES																

PRINCIPAL SKINNER (CONT'D)

Hmm. (VERY SATISFIED SOUNDS) Doris?

FILM ROMAN

THE SIMPSONS

TITLE _____

SHOW 2F03

ACT III

PAGE 199



ACTION

Doris samples a finger full.

TRANS.

check
gumbo
model / size

* DORIS WIPES BARE ARM
see her take
sample

DIAL

LUNCHLADY DORIS
What? What do you got here?

LUNCHLADY DORIS (CONT'D)
(SOMEWHAT PLEASED) Oh.

TRANS.

NOTES

FILM ROMAN

THE SIMPSONS

TITLE _____ SHOW ZFO3 ACT III PAGE 200

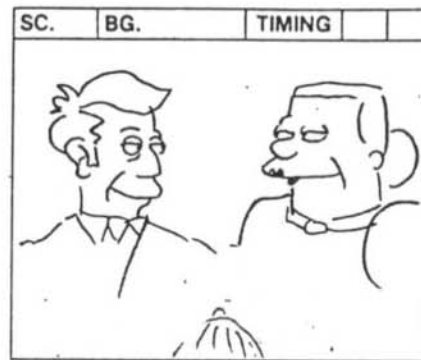
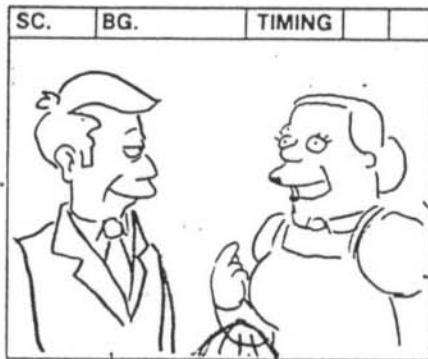
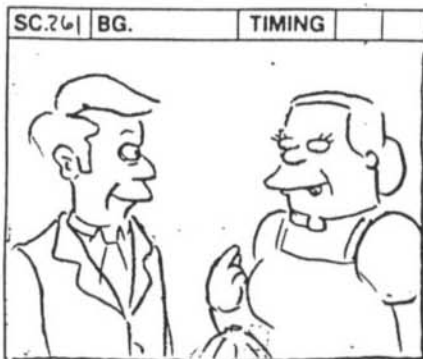

ACTION

Skinner and Lunchlady Doris exchange meaningful looks.

TRANS.

DIAL

(DORIS...)
(AFTER A BEAT, VERY PLEASED) Oh!

... ASSIST!!

PRINCIPAL SKINNER

(SHIFTILY) Uh, Jimbo, why don't you
"assist" Lunchlady Doris in the
kitchen.

JIMBO

Bite me, Skinner.

TRANS.

NOTES

cut to the

FILM ROMAN

THE SIMPSONS

TITLE _____

SHOW 2F03

ACT III

PAGE 201

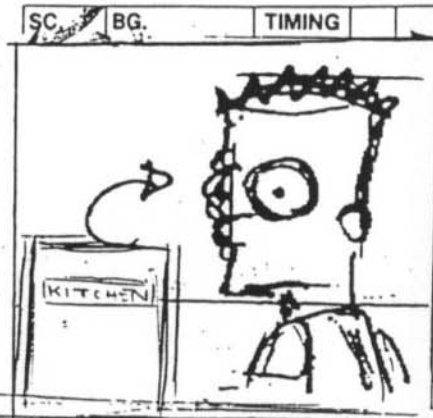
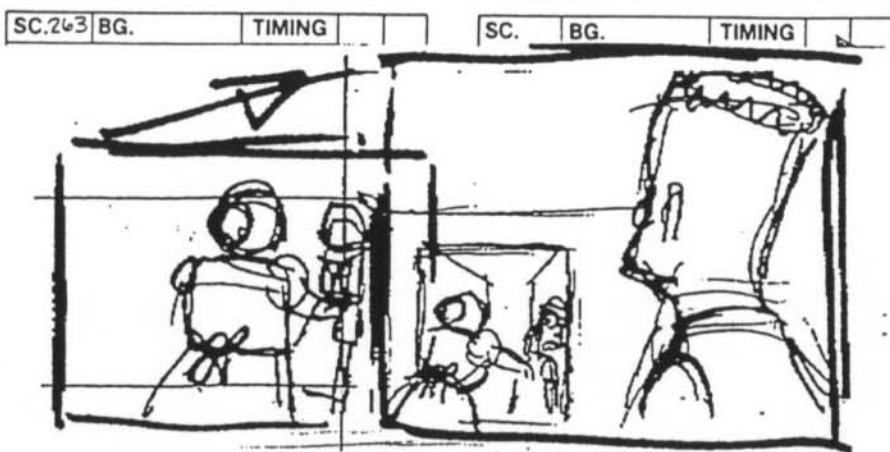
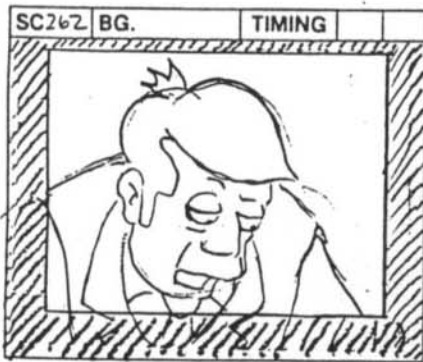

ACTION

TRANS.

DIAL

TRANS.

NOTES

Lunchlady Doris firmly pushes Jimbo into the kitchen and SLAMS the door shut behind them.

PRINCIPAL SKINNER
(MEANINGFUL NODDING) Well might we.

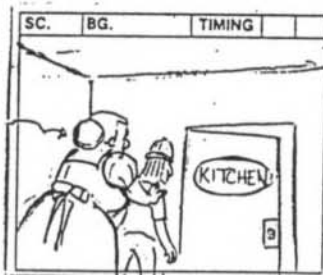

FILM ROMAN

THE SIMPSONS

TITLE _____

SHOW 2F03

ACT III

PAGE 202

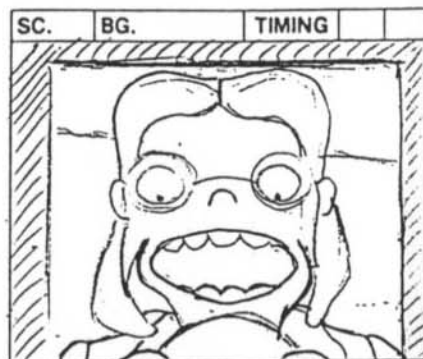
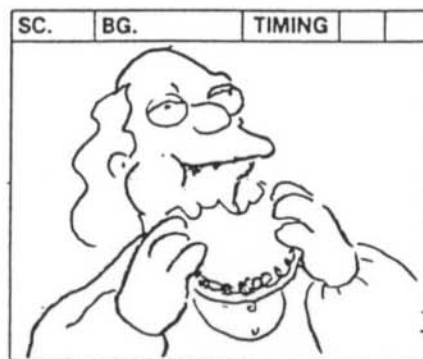
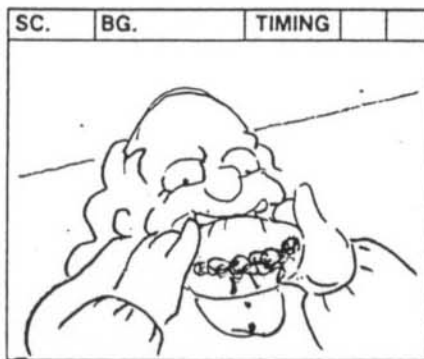
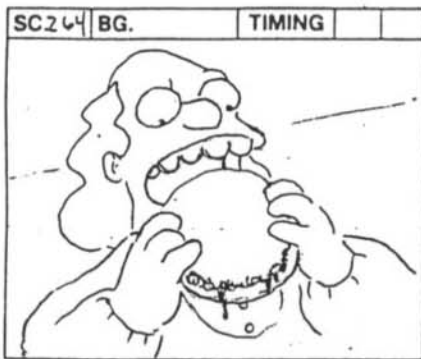

ACTION

INT. CAFETERIA - FACULTY TABLE - THE NEXT DAY
 Mrs. Krabappel, MISS HOOVER, other TEACHERS, and Principal Skinner are eating ravenously.

TRANS.

START POSE

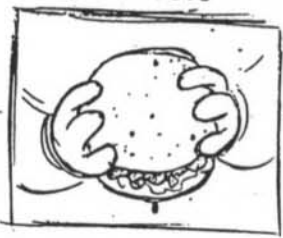

DIAL

TRANS.

NOTES

FILM ROMAN

THE SIMPSONS

TITLE _____

SHOW 2F03ACT IIIPAGE 203

CONT

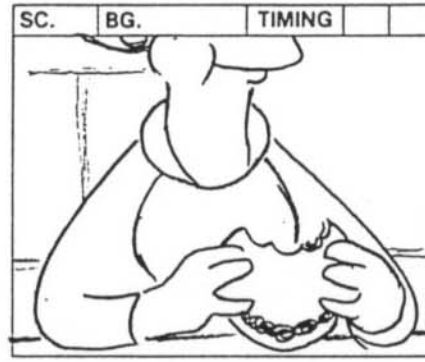
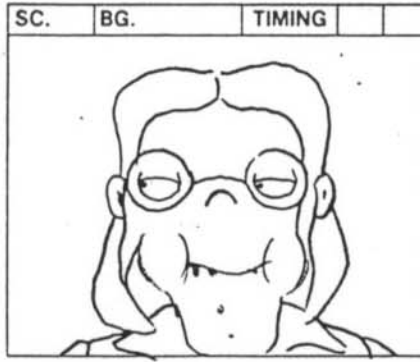
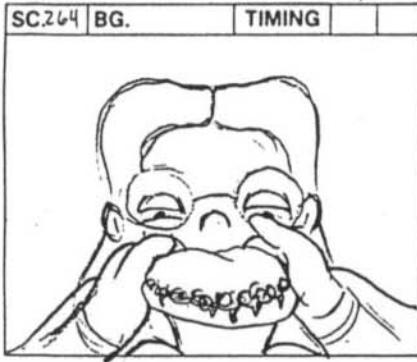

ACTION

TRANS.

DIAL

TRANS.

NOTES

FILM ROMAN

THE SIMPSONS

TITLE _____

SHOW 2F03

ACT III

PAGE 204

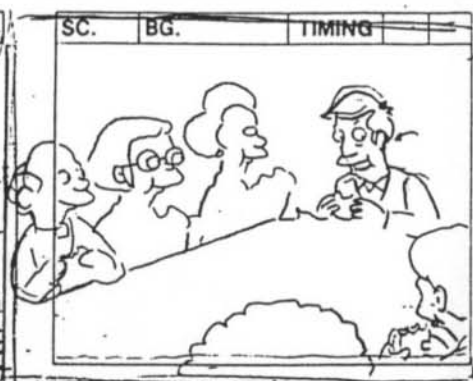
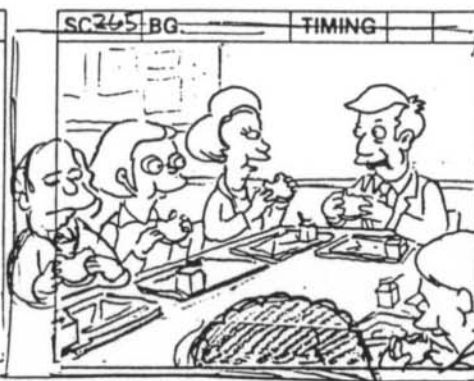

ACTION

TRANS.

DIAL

TRANS.

NOTES

MRS. KRABAPPEL
(SURPRISED) Mmmm. Mm-mmm. This sandwich tastes so young and impudent.

KRABAPPEL: (LAUGHS)
Seymour, what's with the good grub?
PRINCIPAL SKINNER
Hmmm. Well, perhaps I ought to let you folks in on a secret.

... SKINNER: (CONFIDENTIALLY)
Do you remember me telling Jimbo Jones that I'd make something of him one day?

FILM ROMAN

THE SIMPSONS

TITLE _____

SHOW 2F03

ACT III

PAGE 205

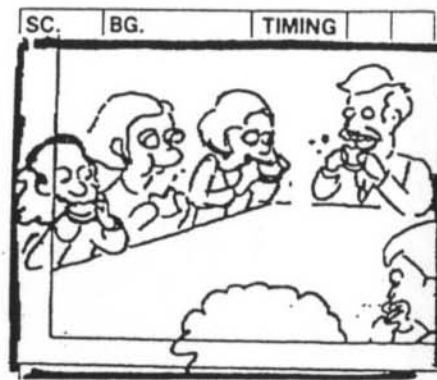
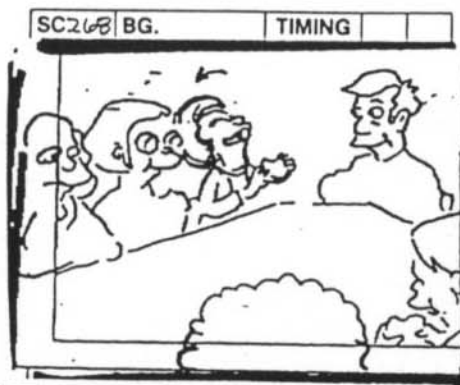

ACTION

wide-eyed

Skinner nods affirmatively and taps a finger to his nose.

The teachers continue eating with even more enthusiasm.

TRANS.

DIAL

MRS. KRABAPPEL
(STUNNED) Are you saying you killed Jimbo, processed his carcass, and served him for lunch?

MRS. KRABAPPEL (CONT'D)
Ha!

TRANS.

NOTES

FILM ROMAN

THE SIMPSONS

TITLE _____

SHOW 2F03

ACT III

PAGE 206

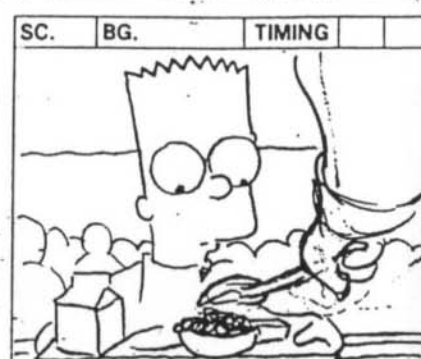
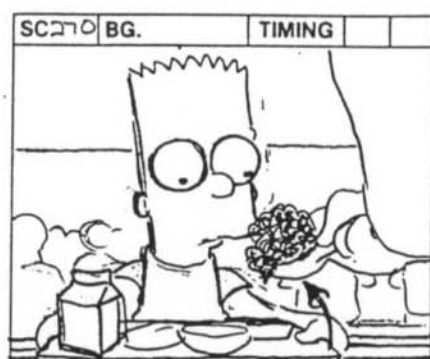
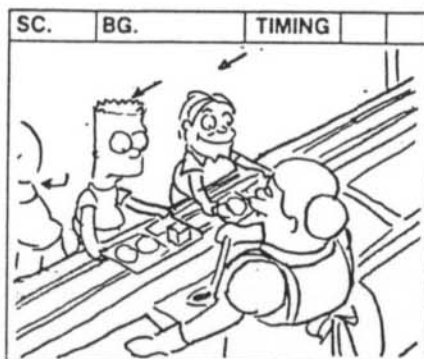
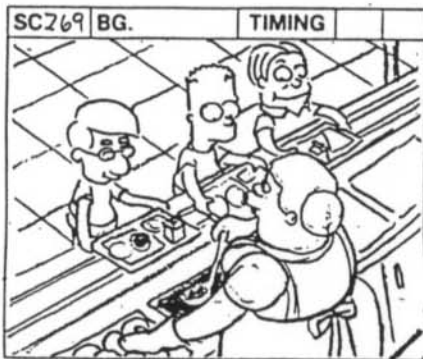

ACTION



 BART LOOKING OVER HIS SHOULDER DURING THESE SCENES. ANTICIPATING JIMBO'S ARRIVAL.



TRANS.

ANGLE ON CAFETERIA LINE
Bart, Milhouse, and MARTIN are moving through the line.

Have wter cut in line between

DIAL

BART
Hmm, I wonder where Jimbo is today.

TRANS.

NOTES

FILM ROMAN

THE SIMPSONS

TITLE _____

SHOW 2F03

ACT III

PAGE 207

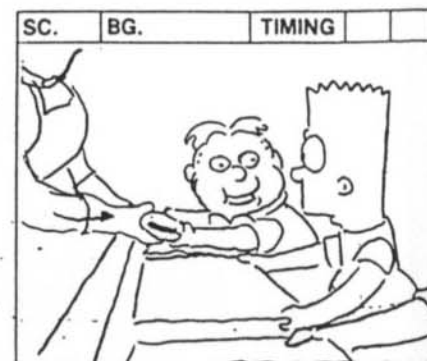
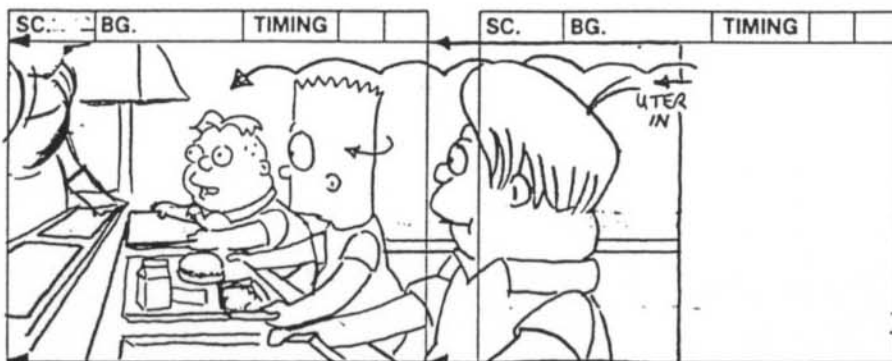
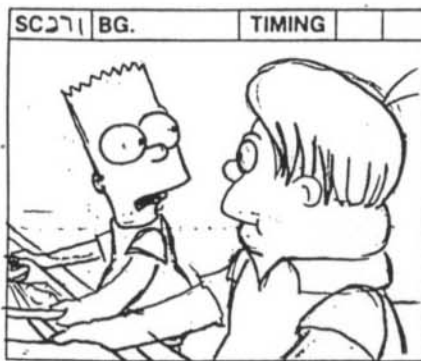

ACTION

UTER (the foreign exchange student) eagerly cuts in front of them, tray in hand.

TRANS.

DIAL

BART (CONT'D)

He should've beaten us up for our lunch money an hour ago.

UTER

Frau Lunchlady, please to have another Sloppy Jimbo.

UTER: (TO BART AND MARTIN)
Das is good, nein?

TRANS.

NOTES

FILM ROMAN

THE SIMPSONS

TITLE _____

SHOW 2F03

ACT III

PAGE 208

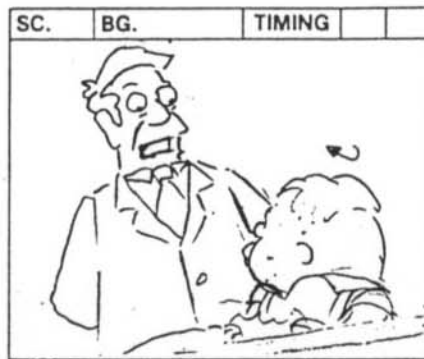

ACTION

Uter begins GULPING it down right there. Skinner comes over.

TRANS.

DIAL

TRANS.

NOTES

PRINCIPAL SKINNER

Now, that's your third helping, young man. It's making you



V.O. SKINNER "fat and soft..."

③

Not so sloppy.

(LICKS LIPS) and tender.

Hmmm... Uh,

FILM ROMAN

THE SIMPSONS

TITLE _____

SHOW 2F03

ACT III

PAGE 209



ACTION

TRANS.

DIAL

TRANS.

NOTES

you just cut in line, didn't you?
(SALIVATING) Report to detention,
Uter.

UTER

For how long?

SKINNER

Oh about seven minutes a pound should
do it.

FILM ROMAN

THE SIMPSONS

TITLE _____

SHOW 2F03

ACT III

PAGE 210

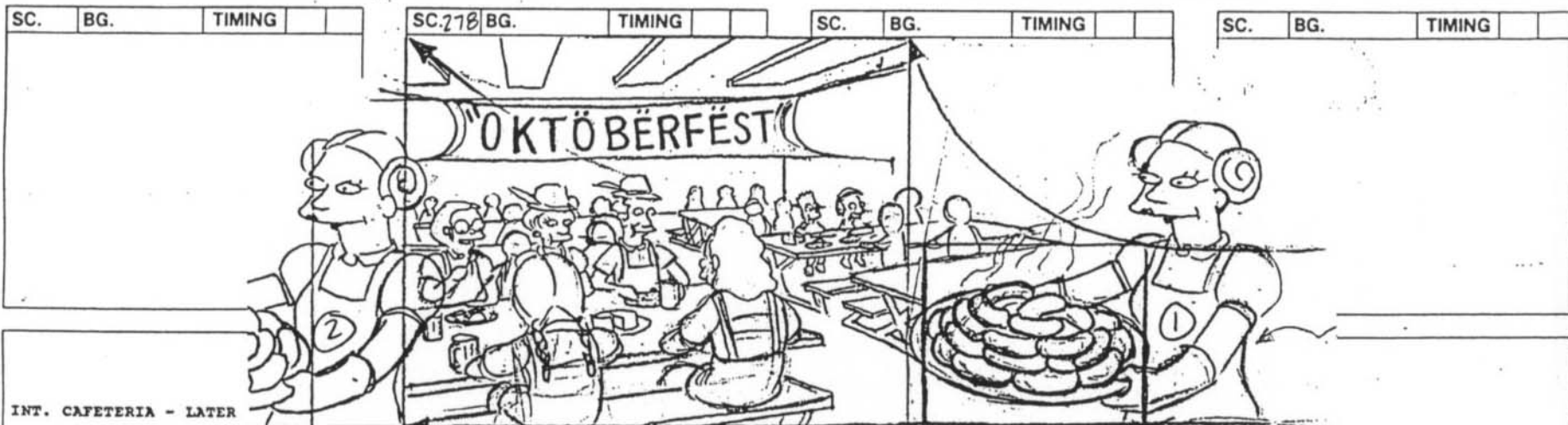

ACTION

INT. CAFETERIA - LATER

We PULL BACK from a plate of sausages. A banner over the cafeteria reads "Oktöberfest." German Oom-pah-pah music PLAYS. The teachers are wearing festive alpine hats.

START

TRANS.

DIAL

TRANS.

NOTES

TITLE _____

 SHOW 2FD3

 ACT III

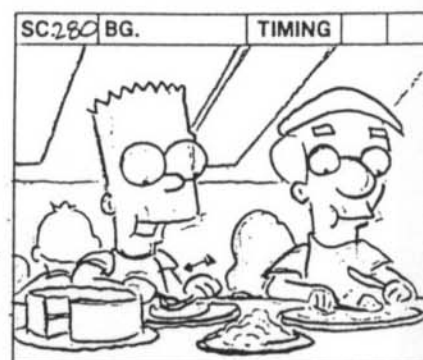
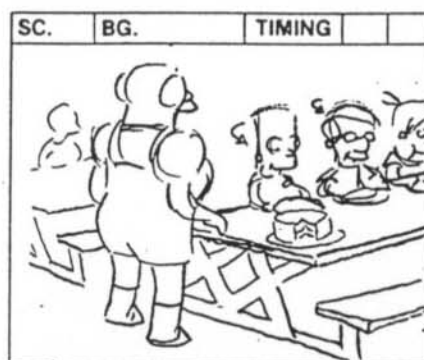
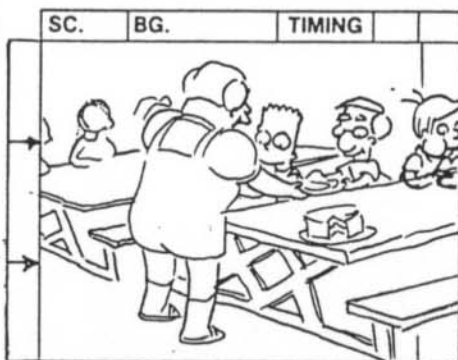
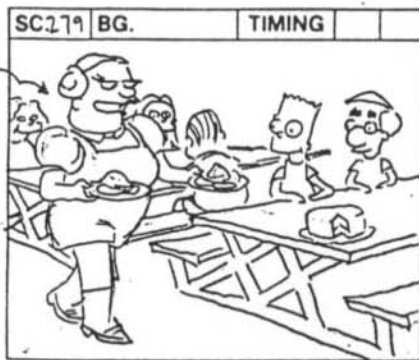
 PAGE 211

ACTION

Lunchlady Doris is dressed in *Liederhosen*.

Bart, Milhouse, and Martin eat hungrily.

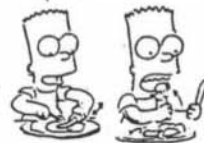

TRANS.

DIAL

LUNCHLADY DORIS

Okay, I got your German grub right here.

BART

Wow, it's too bad Uter's not here. He would've loved this. German chocolate cake... Sauerkraut... Uterbräten...

TRANS.

NOTES

FILM ROMAN

THE SIMPSONS

SHOW 2F03 ACT III PAGE 212

TITLE _____

(CONT.)

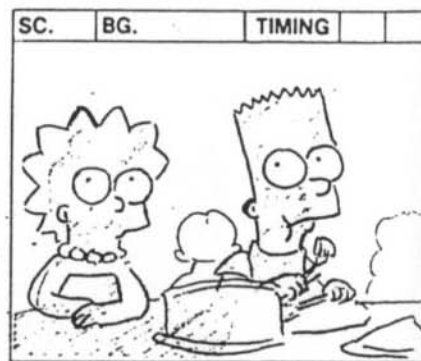
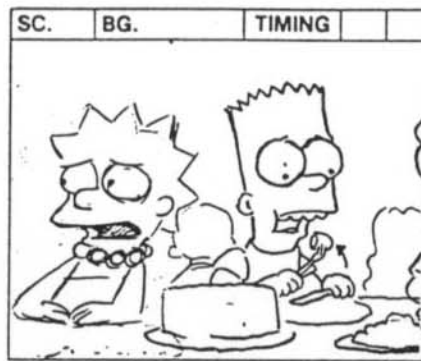
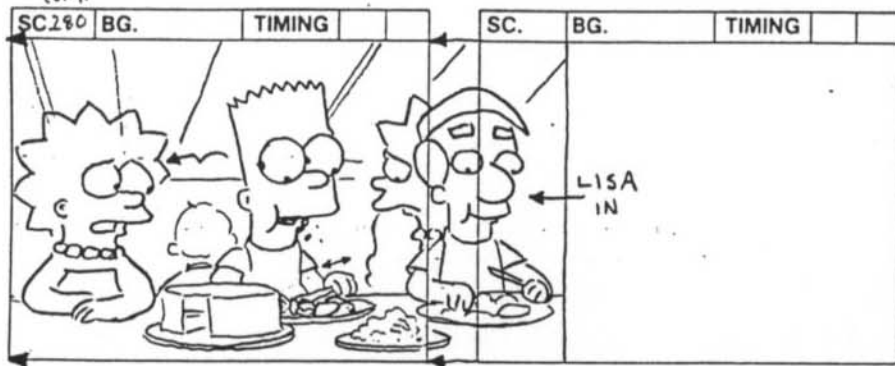

ACTION

LISA approaches worriedly and sits down next to Bart.

normal conversation

BART STOPS MIDWAY IN CHEWING ON: "UTERBRÄTEN"

Bart grows pale and stops chewing.



SHADOW GROWS OVER LISA + BART.

He and Lisa exchange a worried look just as Skinner walks up.

TRANS.

DIAL

LISA -
Bart, does it strike you as odd that Uter disappeared and suddenly they're serving us this mysterious ...

... food called Uterbräten?

TRANS.

NOTES

FILM ROMAN

THE SIMPSONS

TITLE _____

 SHOW 2F03

 ACT III

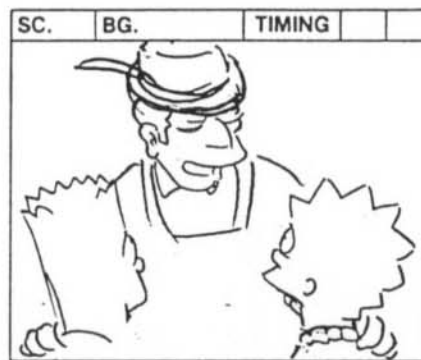
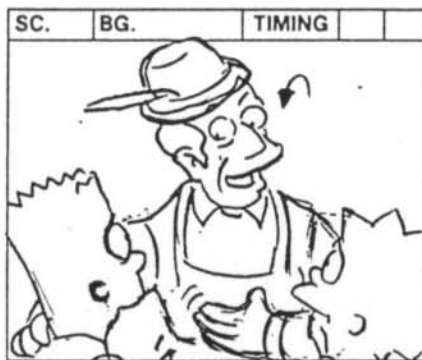
 PAGE 213

ACTION

TRANS.

DIAL

TRANS.

NOTES

PRINCIPAL SKINNER

 Oh relax, kids. I've got a gut feeling.

Uter's around here somewhere.

(CHUCKLES)

After all, isn't there a

FILM ROMAN

THE SIMPSONS

TITLE _____

SHOW 2F03

ACT III

PAGE 214

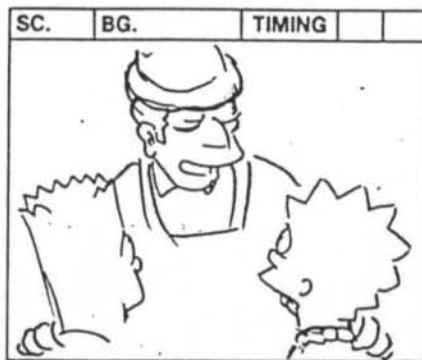

ACTION

TRANS.

DIAL

little Uter in all of us?

(LONGER CHUCKLE)

In facty-you might even say

we just ate Uter and he's in our

TRANS.

NOTES

FILM ROMAN

THE SIMPSONS

TITLE _____

SHOW _____

2F03

ACT _____

III

PAGE 215

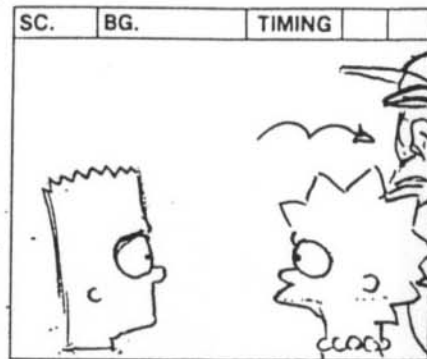
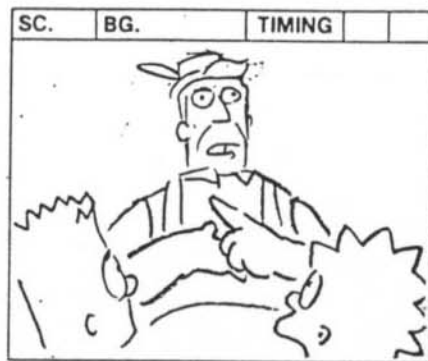

ACTION

*points
to stomach*

TRANS.



Bart and Lisa exchange
another worried look.

DIAL

stomachs right now.

(LAUGHS HARD,

THEN, ABRUPTLY)

Wait. Scratch that.

TRANS.

NOTES

FILM ROMAN

THE SIMPSONS

TITLE _____

SHOW 2F03

ACT III

PAGE 216

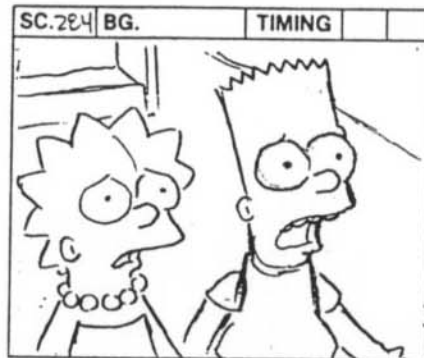
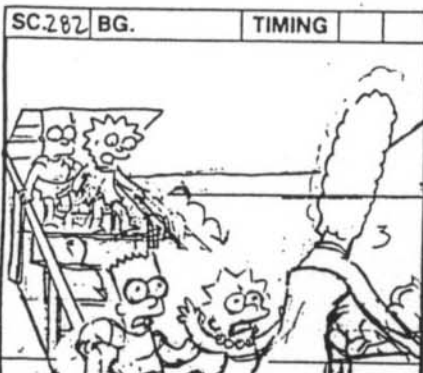

ACTION

INT. SIMPSON HOUSE

Bart and Lisa run in. Marge is loading the washing machine.

TRANS.

Too many stars

Marge continues loading clothes.

DIAL



LISA

Mom! Dad! You've gotta help! They're cooking kids in the school cafeteria!

MARGE

Listen, you're eight and ten years old now. I can't be fighting all your battles for you.

BART

But Mom!

MARGE

No buts.

TRANS.

Tighter, then wider.

NOTES

FILM ROMAN

THE SIMPSONS

TITLE _____

SHOW 2F03

ACT III

PAGE 217

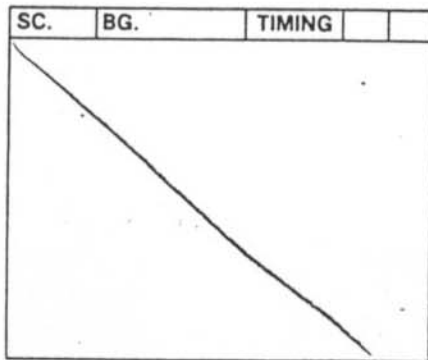
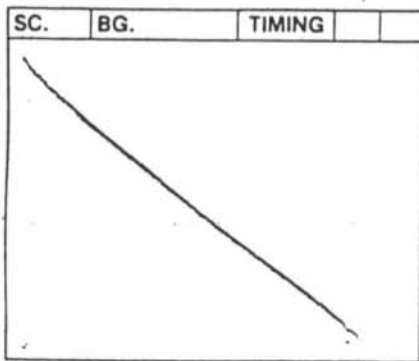

ACTION

TRANS.

DIAL

TRANS.

NOTES

		<p>You march right back to that school, look them straight in the eye and say "don't eat me."</p>	<p>BART/LISA (DEFEATED) Okay.</p>

FILM ROMAN

THE SIMPSONS

TITLE _____

SHOW 2F03

ACT III

PAGE 218

SC.286 SC. BG. TIMING BG. TIMING

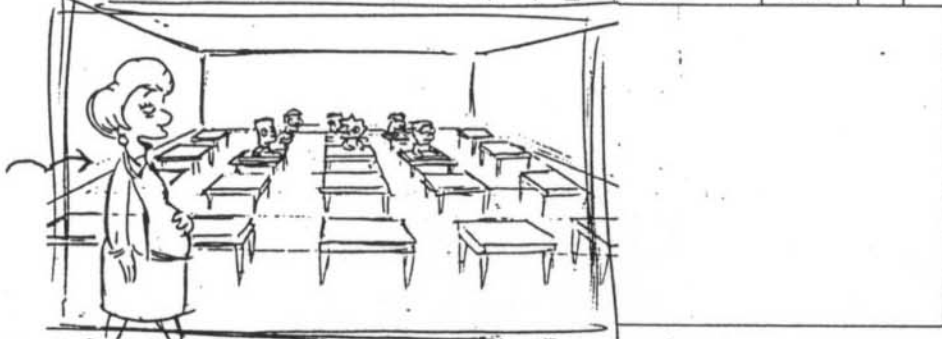

SC.287 BG. TIMING



SC. BG. TIMING



ACTION

INT. MRS. KRABAPPEL'S CLASS

Bart, Lisa, Martin, Milhouse, WENDELL, and RALPH remain.
Mrs. Krabappel now has a significant pot belly.

TRANS.

nose Martin

DIAL

MRS. KRABAPPEL

Since so many students have been put on

"permanent detention"

(SUPPRESSES BURP),

TRANS.

NOTES

FILM ROMAN

THE SIMPSONS

TITLE _____

SHOW 2F03

ACT III

PAGE 219

CONT.

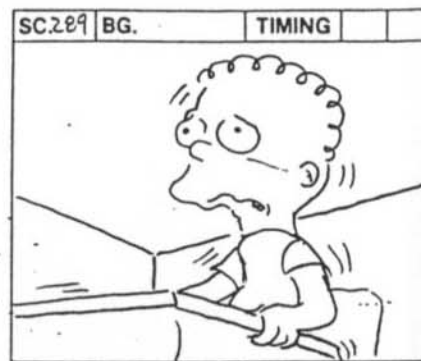
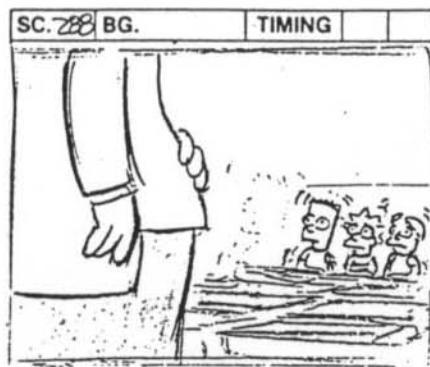

ACTION

The terrified kids try to stay
perfectly still.

Wendell is so frightened,
he actually starts shaking.

TRANS.

*Truck in on
kids*

Truck in

DIAL

we've merged everyone into a single
class.

I trust there are no objections?

*add insert of
Krawinkel's eyes
shifting*

TRANS.

NOTES

FILM ROMAN

THE SIMPSONS

SHOW 2F 0003 ACT III PAGE 220

TITLE _____

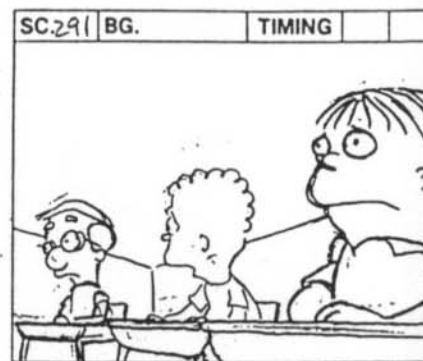
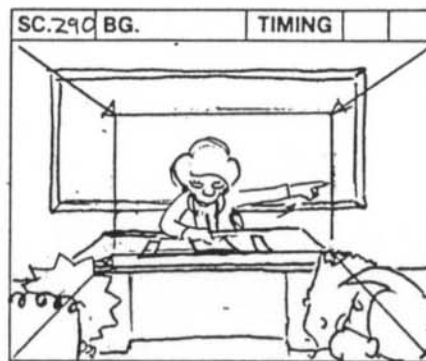

ACTION

causing his desk to vibrate,
sending his pencil ROLLING to the floor.

Without even looking up,
Mrs. Krabappel points to the door.

TRANS.

Wendell looks around nervously
at the others, but they
refuse to make eye contact.

DIAL

MRS. KRABAPPEL (CONT'D)

TRANS.

(LAUGHS) Detention.

NOTES

FILM ROMAN

THE SIMPSONS

TITLE _____

SHOW _____

0003

ACT _____

III

PAGE 221

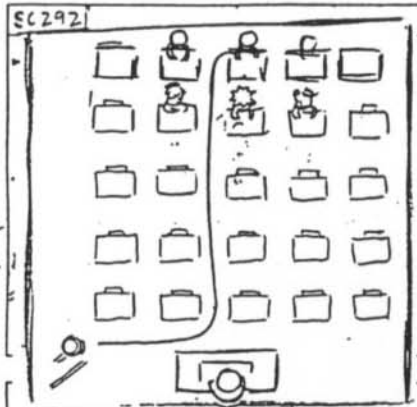

ACTION

He slinks out, defeated.

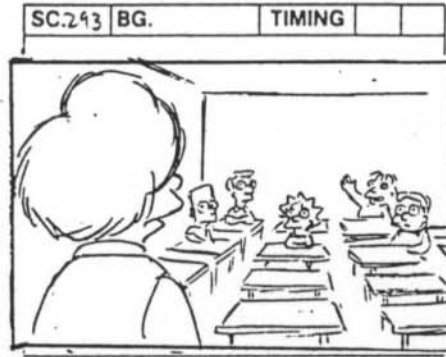

TRANS.

DIAL

TRANS.

NOTES

Too big acting

cut to CU

RALPH

Mrs. Krabappel, I ate some of my boogers. Should I go to detention too?

MRS. KRABAPPEL

(SQUINCHING FACE) Ew, no.

FILM ROMAN

THE SIMPSONS

TITLE _____ SHOW 0003 ACT III PAGE 222

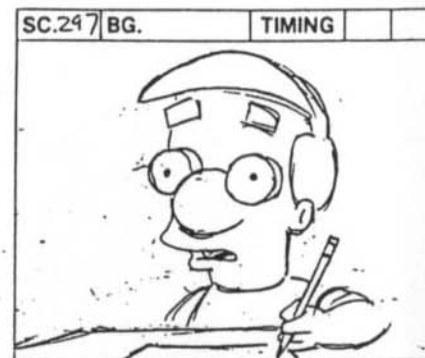
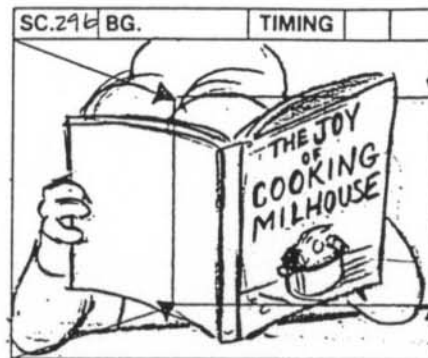
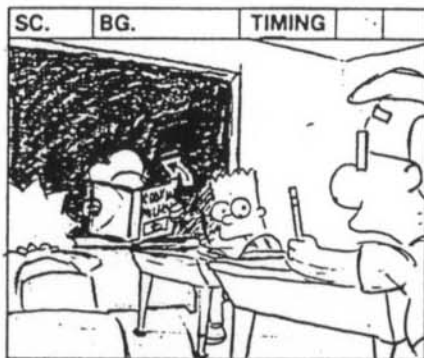
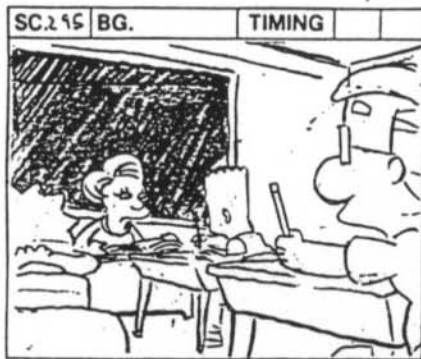

ACTION

INT. MRS. KRABAPPEL'S CLASS - LATER

Mrs. Krabappel begins reading a book entitled "The Joy of Cooking Milhouse." The front cover is a picture of Milhouse's head in a pot.

BOOK TO BE DESIGNED

TRANS.

DIAL

TRANS.

NOTES

FILM ROMAN

THE SIMPSONS

TITLE _____

SHOW 0003

ACT III

PAGE 223

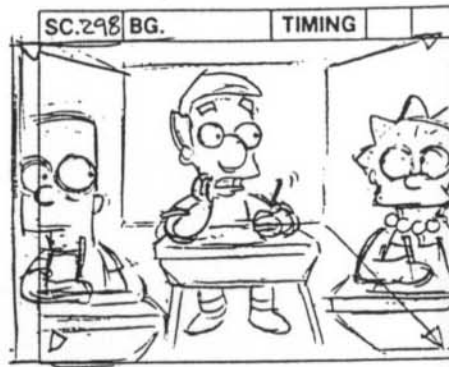
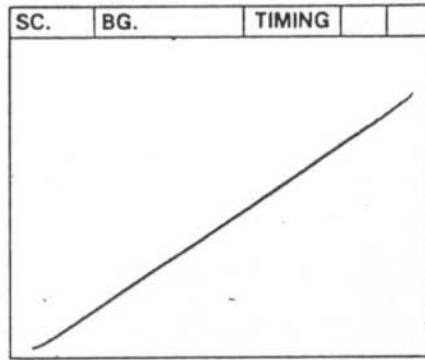
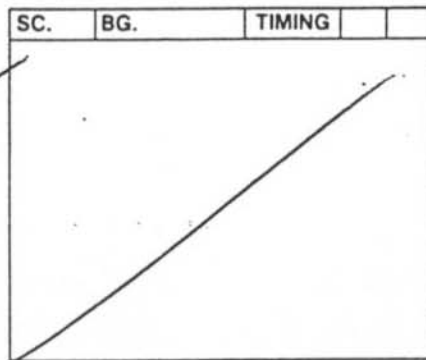
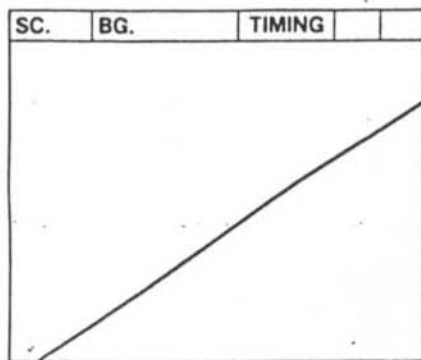

ACTION				
TRANS.				<p>Milhouse looks nervously towards Bart and Lisa.</p>
DIAL				<p>MILHOUSE (WHISPERING) Uhm, uh..psst- hey you guys, I was just thinkin' that any one of us could be next, so what d'ya say we make a break for it?</p>
TRANS.				
NOTES				

FILM ROMAN

THE SIMPSONS

TITLE _____

SHOW 0003

ACT III

PAGE 224

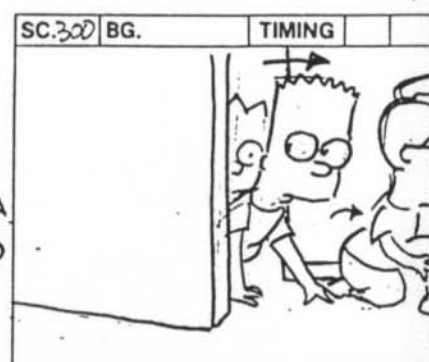
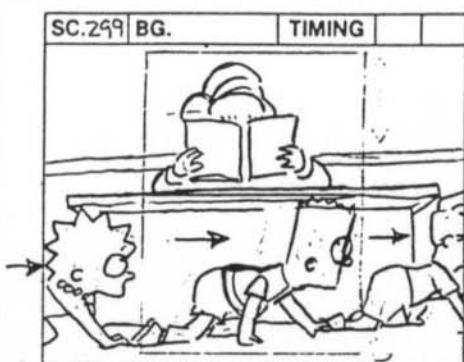
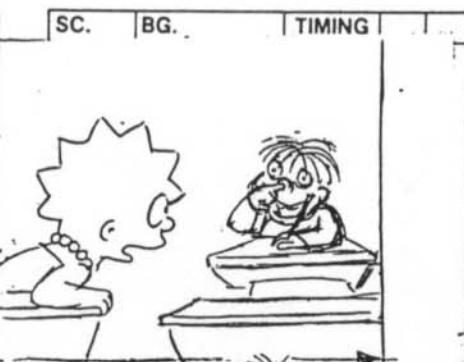
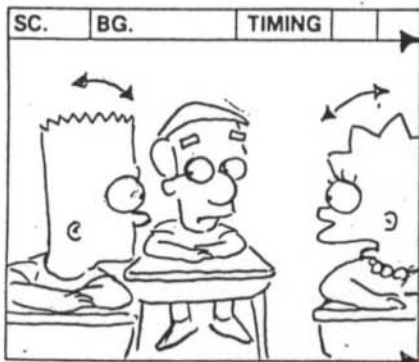

ACTION

Bart and Lisa nod eagerly in agreeer



As Mrs. Krabappel reads,
the kids crawl out of the room.

INT. SCHOOL - CORRIDOR

TRANS.

No fingers in nose

DIAL

LISA
(WHISPERING) Yeah,

you in, Ralph?

RALPH
Ah, no thanks. This booger thing's really
working for me.

TRANS.

NOTES

FILM ROMAN

THE SIMPSONS

TITLE _____

SHOW 0003

ACT III

PAGE 225

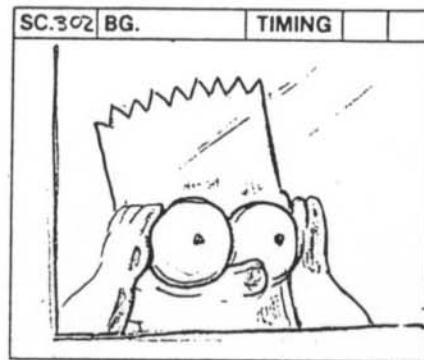
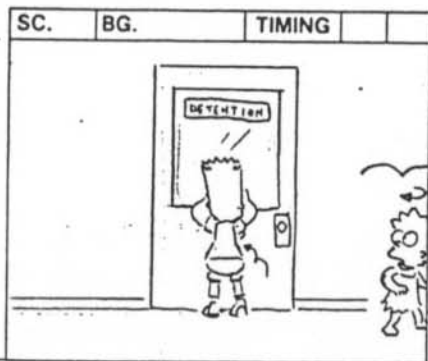
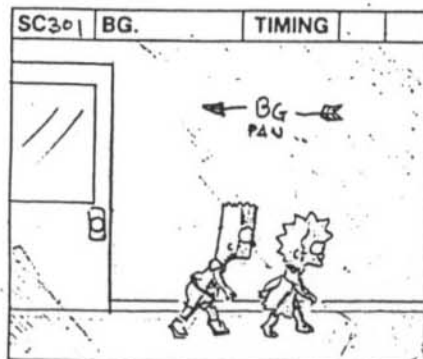

ACTION

The kids creep past the detention room.

Bart peers in the window.

TRANS.

CREEPY LIGHTING

DIAL

TRANS.

NOTES

FILM ROMAN

THE SIMPSONS

TITLE _____

SHOW 0003

ACT III

PAGE 226

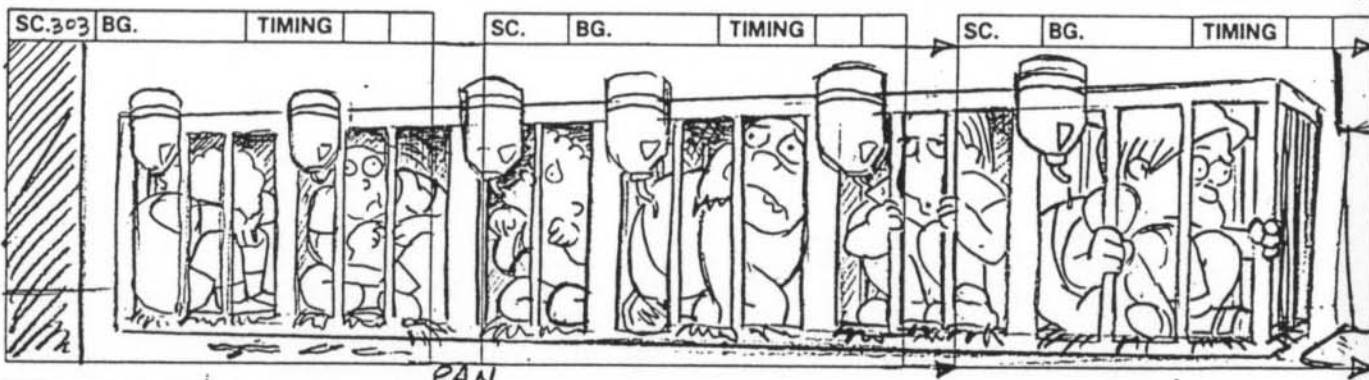
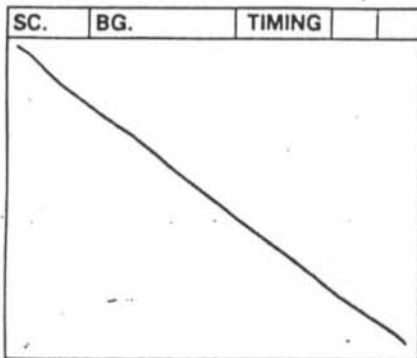

ACTION

INT. DETENTION ROOM - BART'S POV

The room is now lined with tiny veal pens containing immobilized kids. Milk feeder bottles hang upside down along the bars.

slower pan

TRANS.

DIAL

TRANS.

NOTES

FILM ROMAN

THE SIMPSONS

SHOW 0003 ACT III PAGE 227

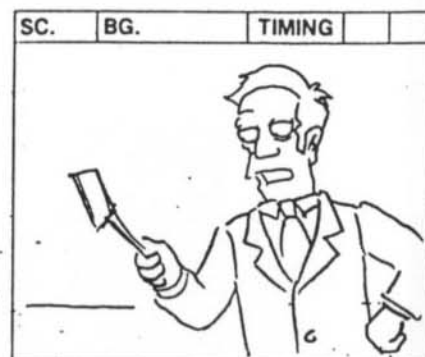
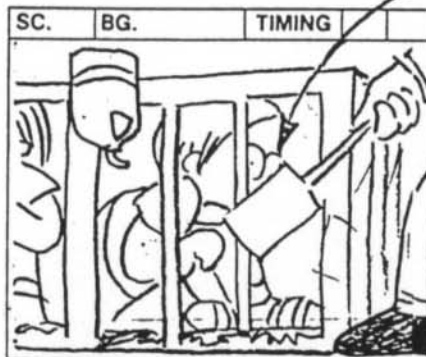
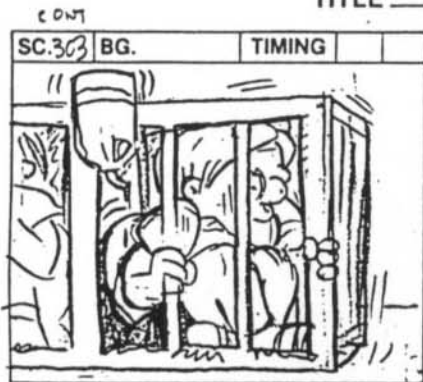

ACTION	<p>Martin struggles against the bars of one cage. Skinner now SMACKS a spatula on his palm instead of a rod.</p>		
TRANS.	<p><i>whacks cage (or loose hit)</i></p>		
DIAL			
TRANS.		<p>PRINCIPAL SKINNER Easy there, young man. You'll only make yourself tired and stringy.</p>	
NOTES			

FILM ROMAN

THE SIMPSONS

TITLE _____

SHOW _____

0003

ACT _____

III

PAGE 228

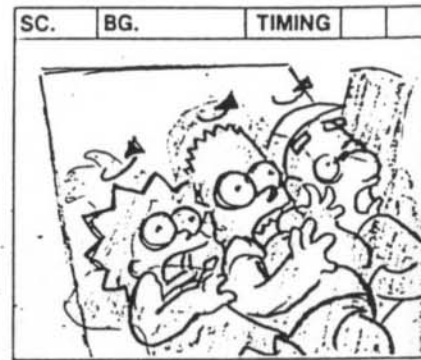
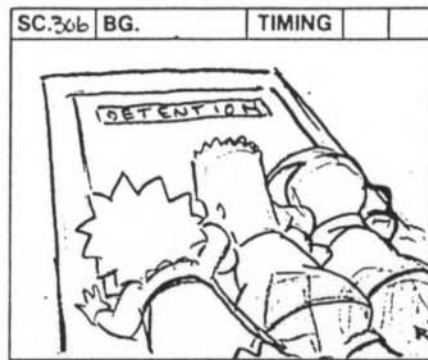
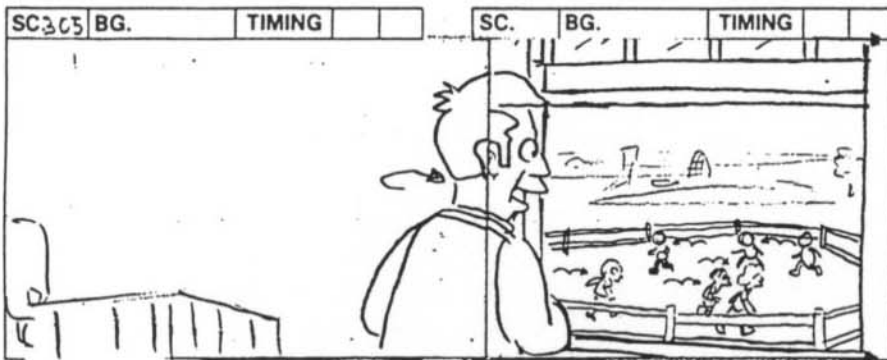

ACTION

Skinner turns and looks out the window, where more kids are running around in a corral.

BACK TO SCENE

DRAMATIC UPSHOT
DORIS' SHADOW CRAWLS
OVER THE KIDS.

TRANS.

PRINCIPAL SKINNER (CONT'D)

Now to check on the free-range children.

PU
SC 305A

DIAL

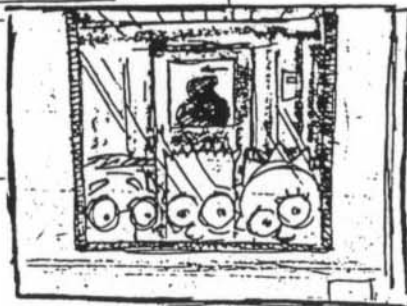

TRANS.

NOTES

FILM ROMAN

THE SIMPSONS

TITLE _____

SHOW 0003

ACT III

PAGE 229

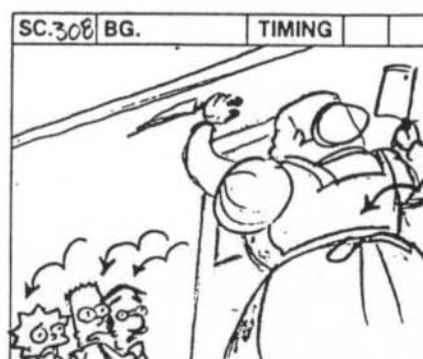
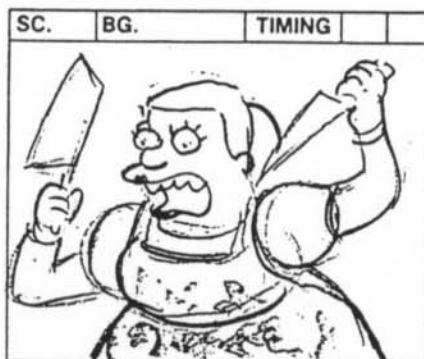

ACTION

Lunchlady Doris suddenly BURSTS through the door wearing a bloody slaughterhouse apron and holding a cleaver and a large knife. She begins advancing on Lisa, Bart and Milhouse.

Suddenly GROUNDSKEEPER WILLIE runs up

TRANS.

DIAL

LUNCHLADY DORIS
(RAVENOUS SNARLING AND SLOBBERING)

GROUNDSKEEPER WILLIE
Hold on kids! I'm comin' to rescue the lot of ye!

TRANS.

NOTES

FILM ROMAN

THE SIMPSONS

TITLE _____

SHOW 0003

ACT III

PAGE 230

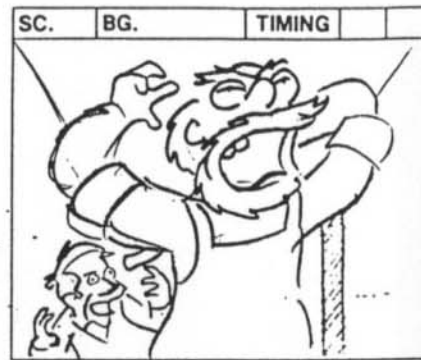
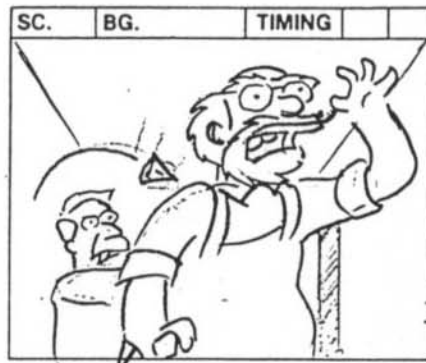

ACTION

Skinner steps behind Groundskeeper Willie and plants an axe deep in his back.

TRANS.

DIAL

GRANDSKEEPER WILLIE (CONT'D)

I'll ju-

ow!

TRANS.

NOTES

FILM ROMAN

THE SIMPSONS

SHOW 0003ACT IIIPAGE 231

TITLE _____

CONT

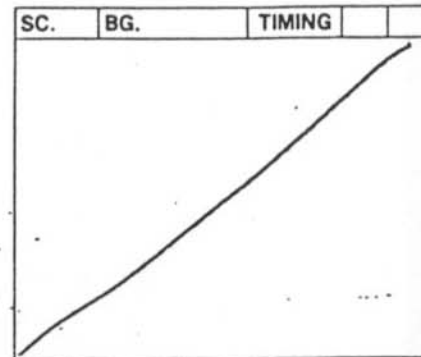
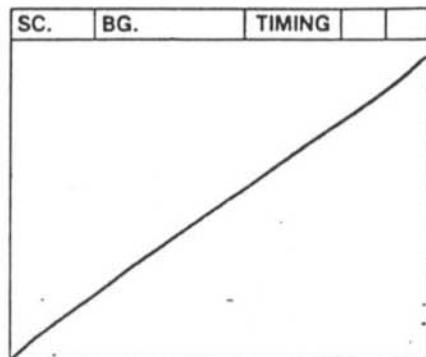
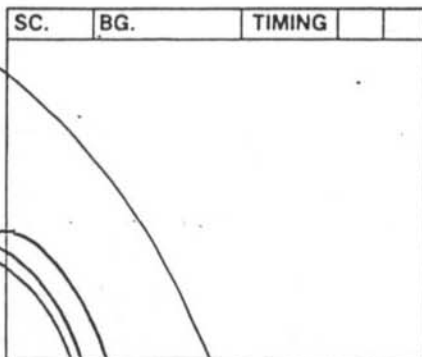
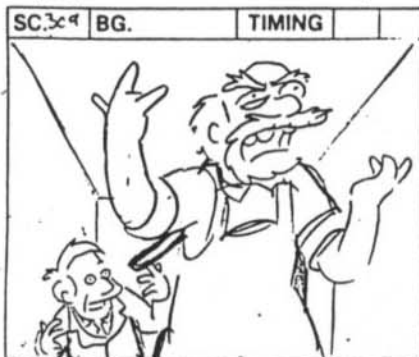

ACTION.

TRANS.

DIAL

Ach, I'm bad at this.

TRANS.

NOTES

FILM ROMAN

THE SIMPSONS

TITLE _____

SHOW 0003ACT IIIPAGE 232

SC. 310	BG.	TIMING		
COLOR CARD MATCH TO BART'S SHIRT				

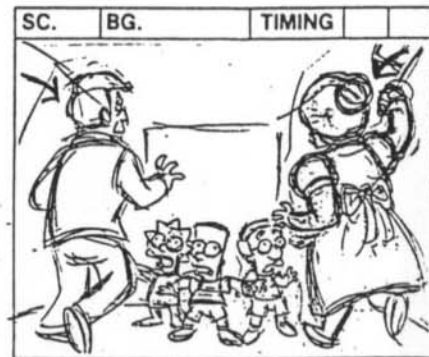
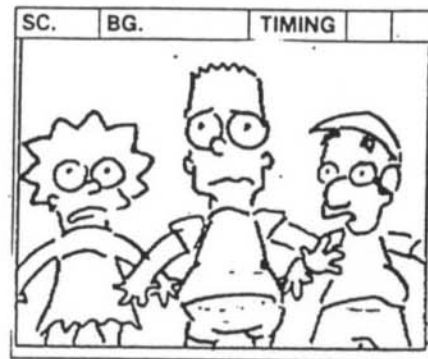
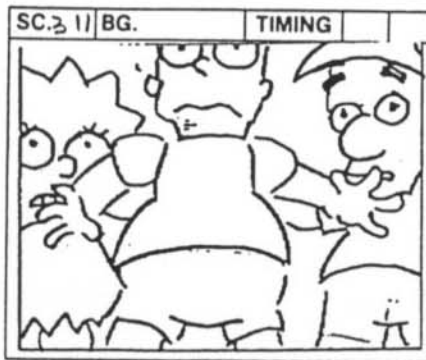

ACTION

TRANS.

DIAL

TRANS.

NOTES

cont'd

TITLE _____

SHOW _____

ACT _____

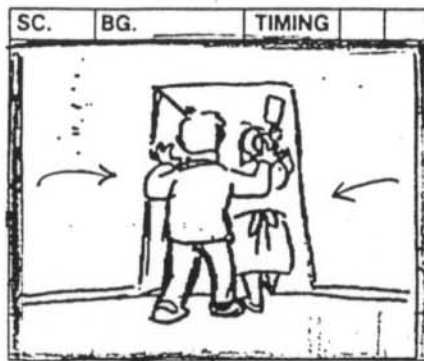
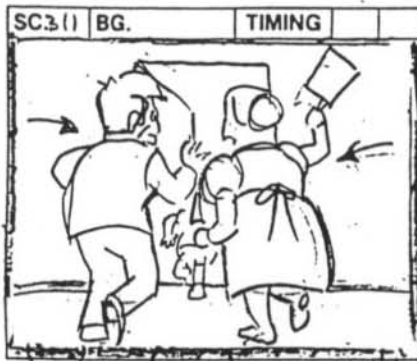

ACTION

TRANS.

DIAL

TRANS.

NOTES

Skinner swiftly dons a bib with the familiar school crossing road sign silhouette.

PRINCIPAL SKINNER

I'm going to enjoy devouring you, Bart Simpson. Yes... I believe I'll start,

CONT

TITLE _____

SHOW 0003

ACT III

PAGE 234

SC.312 BG. TIMING



ACTION

SC.313 BG. TIMING



Bart, Lisa and Milhouse slowly back up to the precipice of a large food processor which reads: HAMILTON BEACH STUDENT CHOPPER.

TRANS.

SC. BG. TIMING

SC.314 BG. TIMING

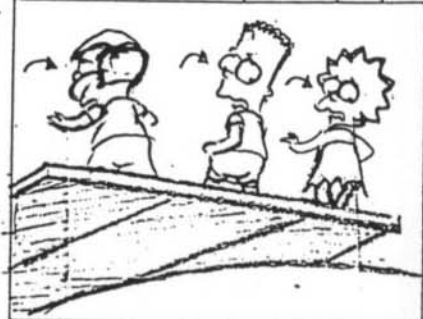

DIAL

SKINNER (CONT'D)

... as you've so often suggested, by eating your shorts.

TRANS.

NOTES

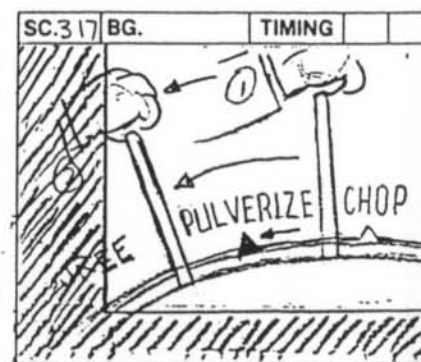
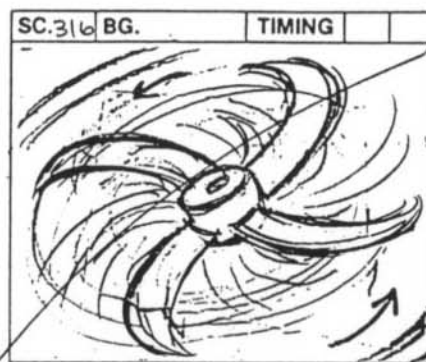
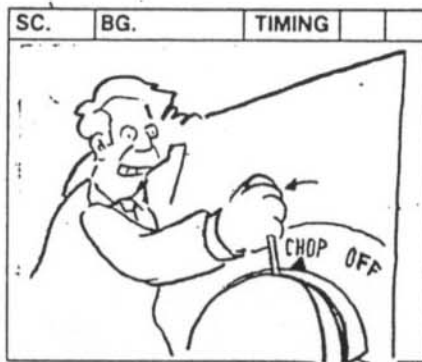
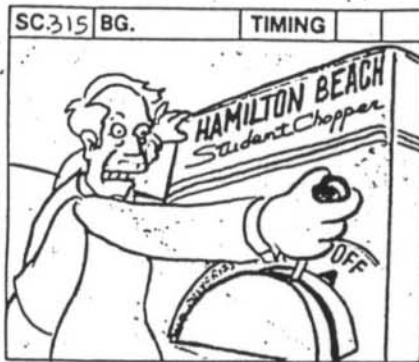

ACTION

ANGLE ON SKINNER

Skinner puts his hand on a switch and slowly pushes it from the "OFF" position to the setting marked "CHOP." The blades move. He switches it to the setting marked "PULVERIZE"

TRANS.

"Beech"

DIAL

TRANS.

NOTES

FILM ROMAN

THE SIMPSONS

TITLE _____

SHOW 0003

ACT III

PAGE 234

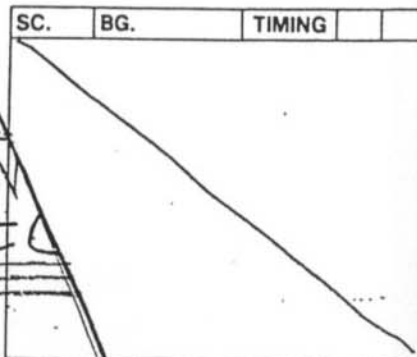
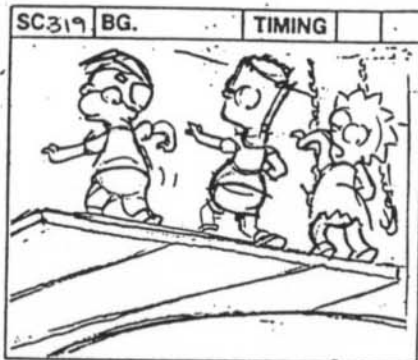
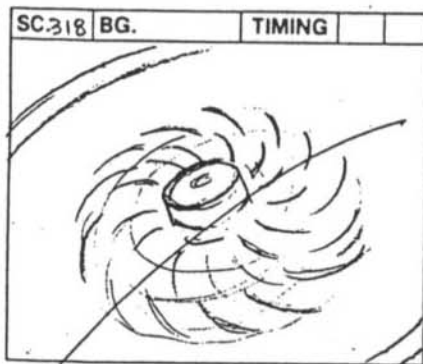

ACTION

and the blades move faster. He switches it to the setting marked "PUREE" and the blades go even faster.

TRANS.

DIAL

TRANS.

NOTES



*Quicker
on dial*

FILM ROMAN

THE SIMPSONS

TITLE _____

SHOW

0003

ACT

III

PAGE 237

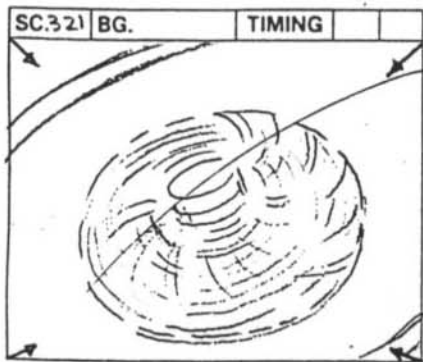

ACTION

T
12

TRANS.

DIAL

TRANS.

NOTES

FILM ROMAN

THE SIMPSONS

TITLE _____

SHOW _____

0003

ACT _____

III

PAGE 238

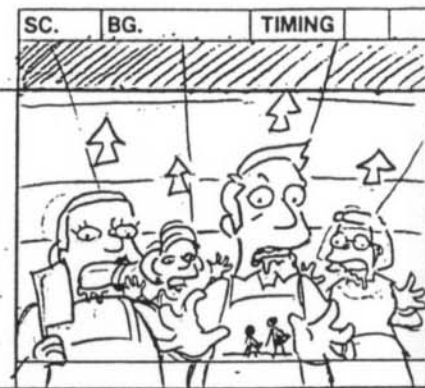
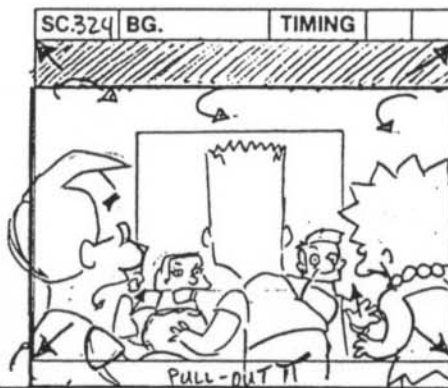
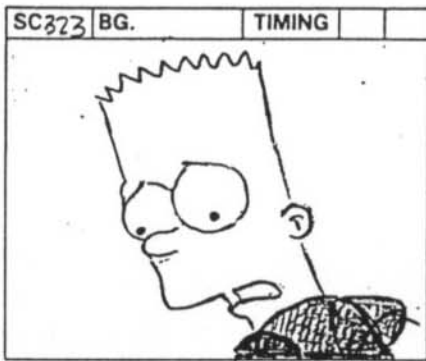

Skinner, Doris, Krabappel and Hoover begin closing in and salivating. Bart, Milhouse, and Lisa continue to back up.

ACT

TR/

He pulls it back to "PUREE" and the blades begin to make a DEAFENING sound.

DIAL

TRANS.

NOTES

FILM ROMAN

THE SIMPSONS

CONT.

TITLE _____

SHOW _____

0003

ACT _____

III

PAGE _____

259

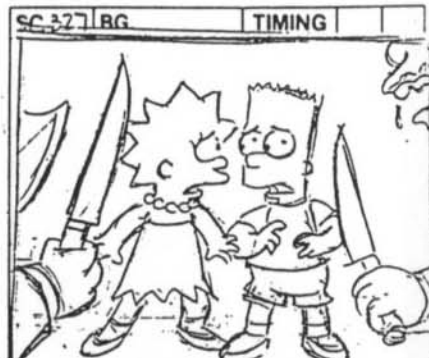
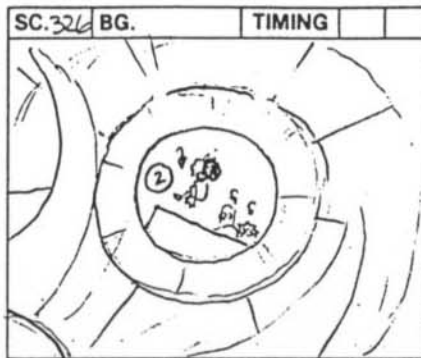

ACTION

Milhouse falls down the chute.

EXTREME UPSHOT FROM INSIDE CHOPPER

TRANS.



NOT TO
SECRETIVE

DIAL

BART

Don't worry, guys. Something always comes along to save us.

MILHOUSE FALLS INTO CAMERA

MILHOUSE

(SCREAMS, ABRUPTLY CUT OFF)

BART

(CLEARS THROAT) Nevertheless, I remain confident that something will come along and save the two Simpson children.

TRANS.

NOTES

FILM ROMAN

THE SIMPSONS

SHOW 0003 ACT III PAGE 240

cont'd

TITLE _____

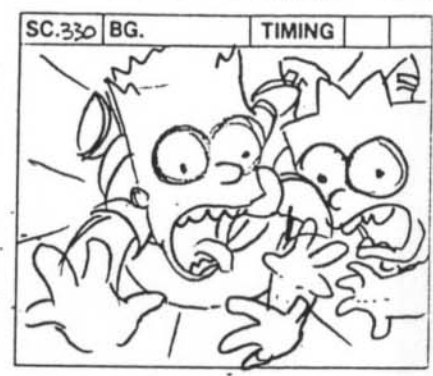
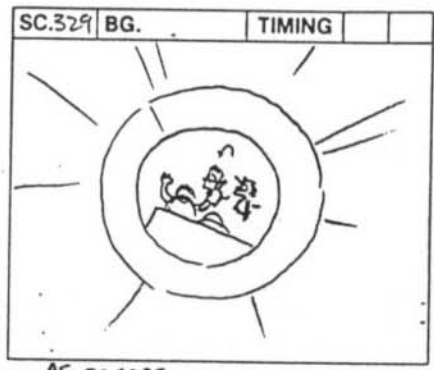
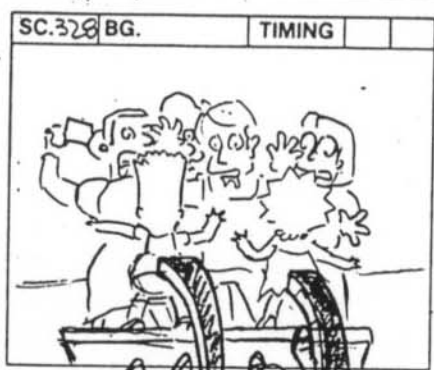
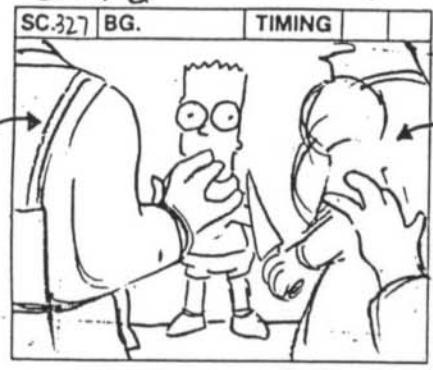

ACTION

TRANS.

DIAL

TRANS.

NOTES

BART + LISA FALL O.S.

... AS BEFORE

BART + LISA FALL INTO CAMERA SCREAMING

FILM ROMAN

THE SIMPSONS

TITLE _____ SHOW 0003 ACT III PAGE 241

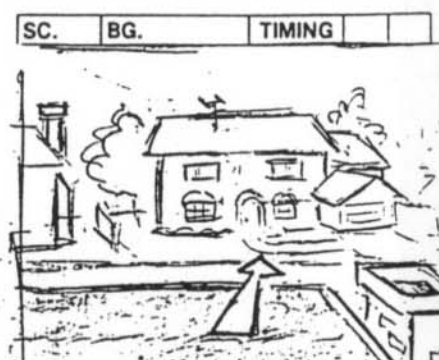
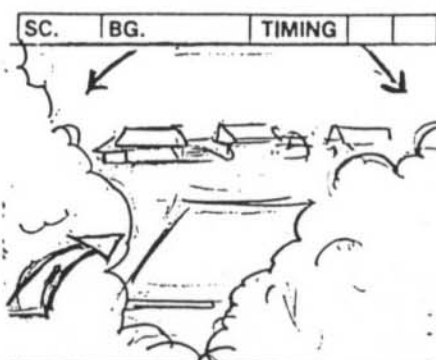
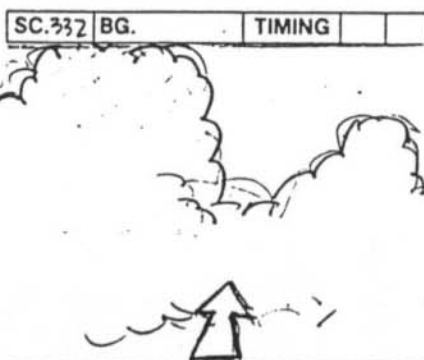
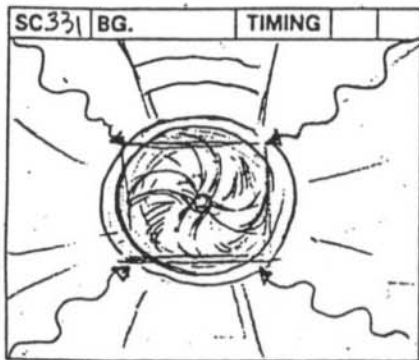

ACTION

BART AND LISA'S POV
Rotating blades are coming at them.
On their rising SCREAMS --

DIRECTOR SUGGESTS LONG
ZOOM FROM WAY BACK
ALA! EVIL DEAD

TRANS.

DIAL

TRANS.

NOTES

FILM ROMAN

THE SIMPSONS

TITLE _____

SHOW _____

0003

ACT _____

III

PAGE 241

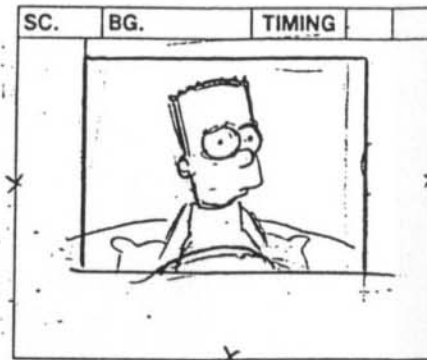
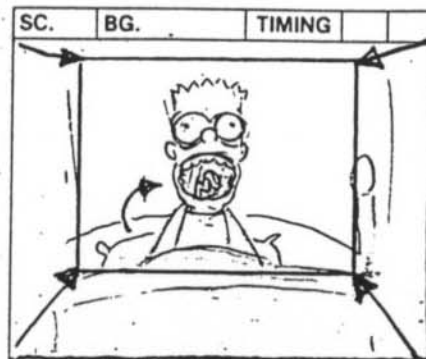
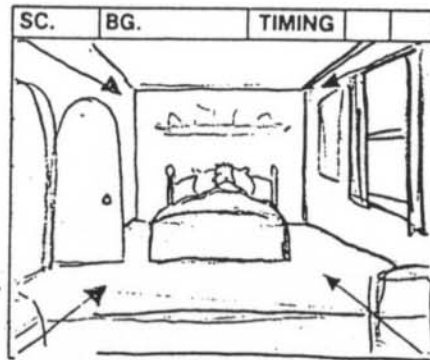
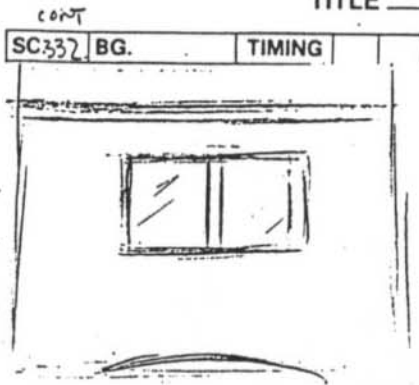

ACTION

DIRECTOR SUGGESTS LONG
ZOOM IN FROM WAY BACK
ALA; EVIL DEAD,

CUT TO:

INT. SIMPSON HOUSE - BART'S BEDROOM - MORNING

We ZOOM IN on Bart bolting upright in bed and SCREAMING.
He awakens to hear only the peaceful CHIRPING of birds.

TRANS.

DIAL

TRANS.

NOTES

TITLE _____

SHOW _____

ACT _____

PAGE _____

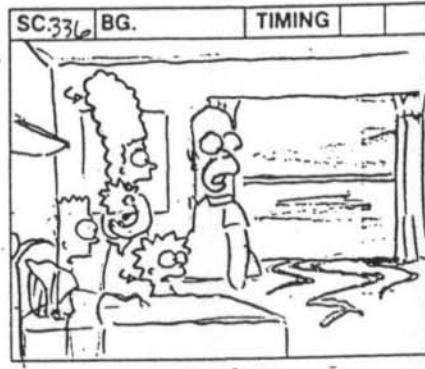
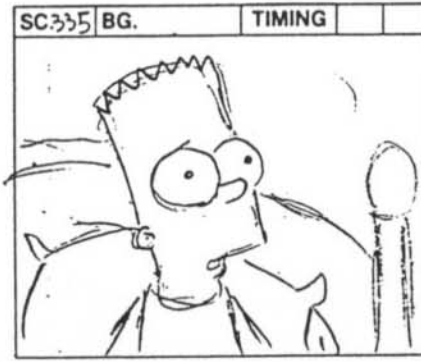

ACTION

> THIS SET-UP SEE WIZARD
OF OZ FINAL SCENES.

Bart's family is around him. Lisa is fine.

We see a dark fog begin to seep
underneath the windows.

TRANS.

DIAL

MARGE

Relax, honey. You were just having a
crazy nightmare. You're back with your
family now,

where all you have to worry
about is doing your chores and avoiding
that fog that turns people inside out.

BART

Huh?

HOMER

Uh oh, it's seeping in! (BITTERLY)
Stupid cheap weather stripping.

TRANS.

NOTES

FILM ROMAN

THE SIMPSONS

TITLE _____

SHOW 0003

ACT III

PAGE 243

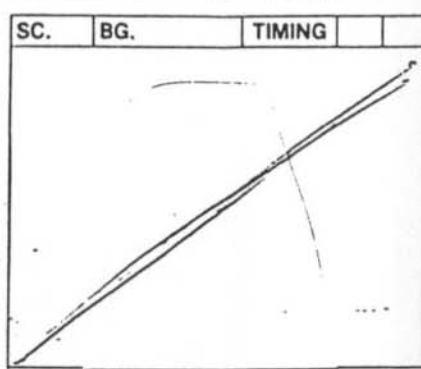
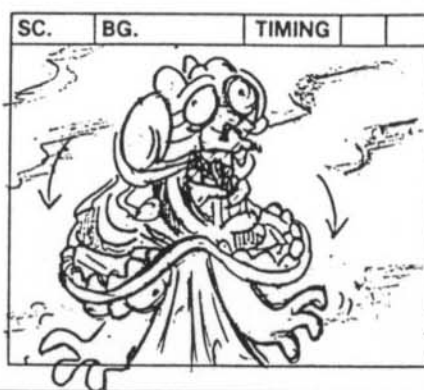
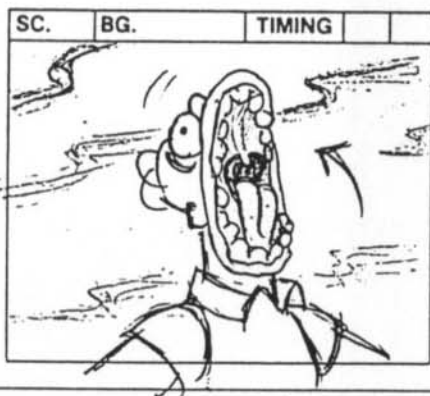
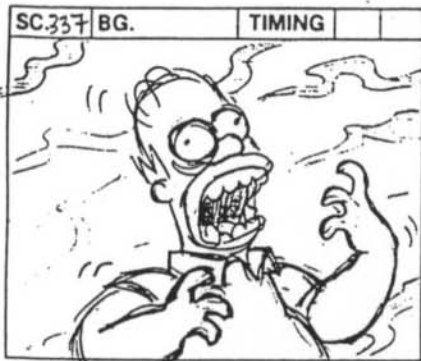

ACTION

HEAD PEELS BACK

TRANS.

DIAL

TRANS.

NOTES

FILM ROMAN

THE SIMPSONS

TITLE _____

SHOW _____

0003

ACT _____

III

PAGE _____

244

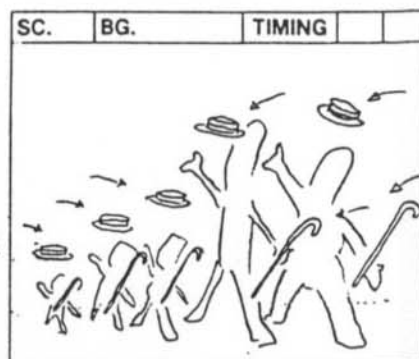
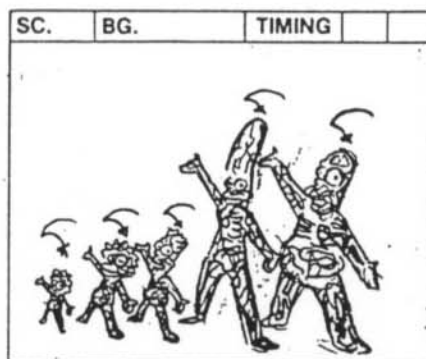
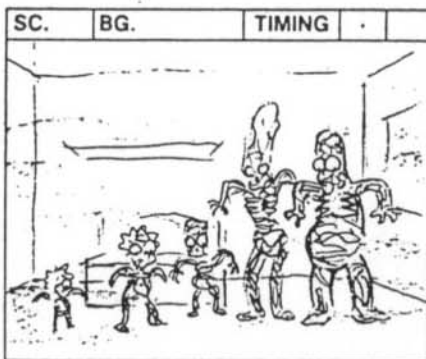
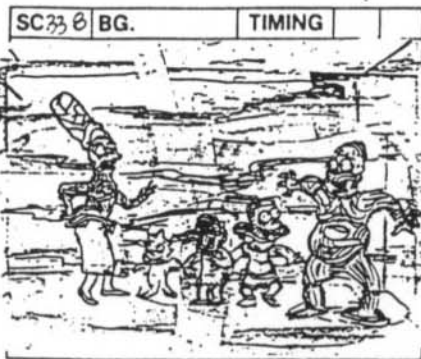

ACTION

The fog comes in and turns the Simpsons inside out, as all SCREAM horribly. They look at each other and then themselves, then begin dancing in a perfectly synchronized chorus line.

Hats and canes are tossed to them from O.

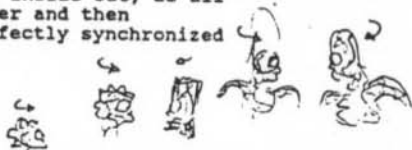

TRANS.

* NOTE - PUT MARGE ON END, KIDS IN MIDDLE FOR REST OF DANCE NUMBER

DIAL

fall on floor?

TRANS.

FAMILY
(SINGING) One --

NOTES

FILM ROMAN

THE SIMPSONS

SHOW 0003 ACT III PAGE 249

TITLE _____

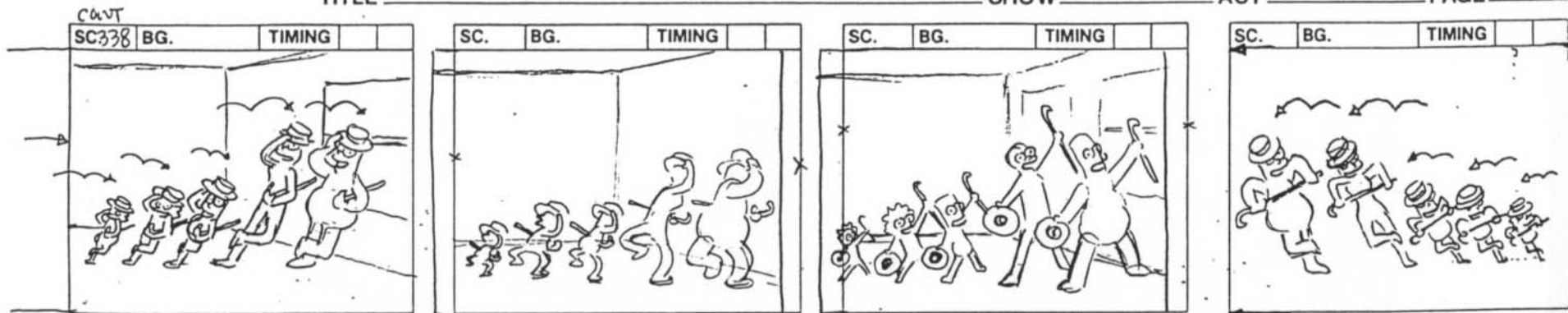

ACTION

TRANS.

DIAL

FAMILY (CONT'D)
Singular sen

-sa-

-tion

Every little

TRANS.

NOTES

FILM ROMAN

THE SIMPSONS

SHOW 0003 ACT III PAGE 246

TITLE _____

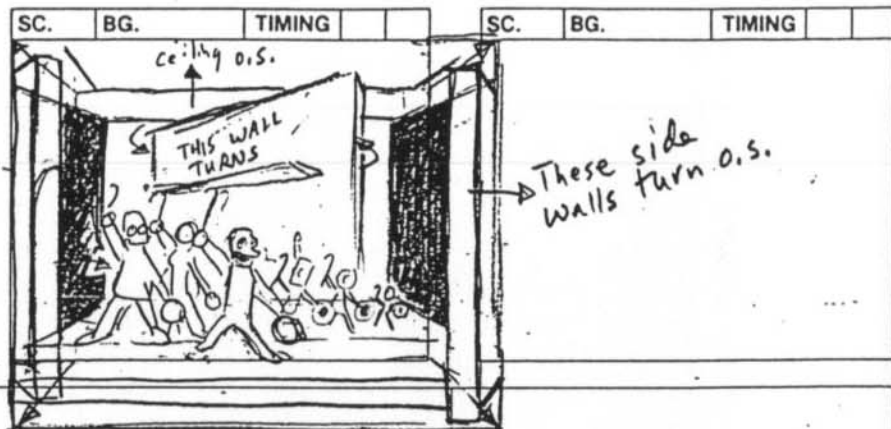
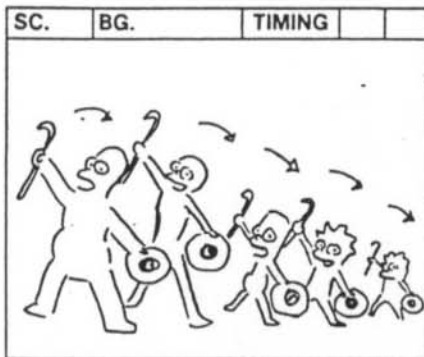
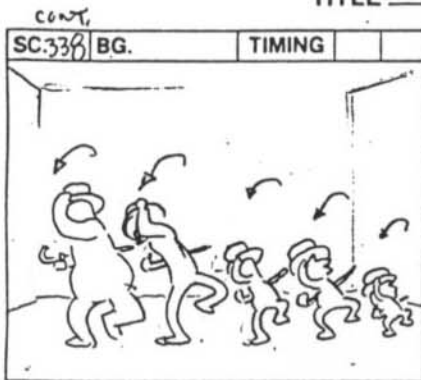

ACTION

PULL-OUT AS!

An inside out Willie with an axe in his back runs in and joins them. The walls of the house flip around and become a glitzy set.

TRANS.

BG finished changing.

DIAL

GROUNDSKEEPER WILLIE

step

we take

One --

TRANS.

NOTES

FILM ROMAN

THE SIMPSONS

SHOW 0003

ACT III

PAGE 248

CONT. TITLE _____

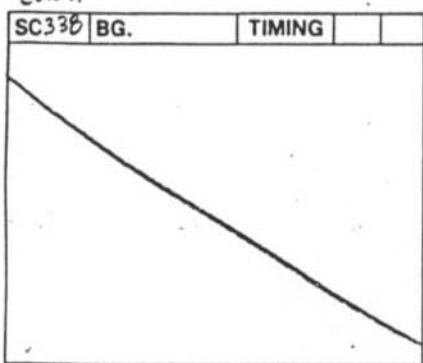

cont'd

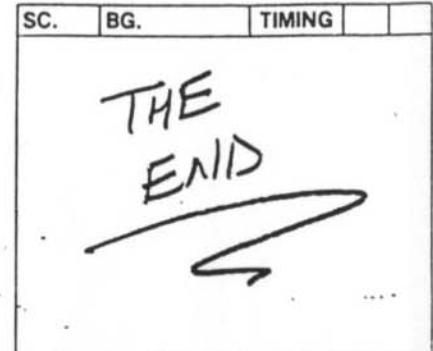
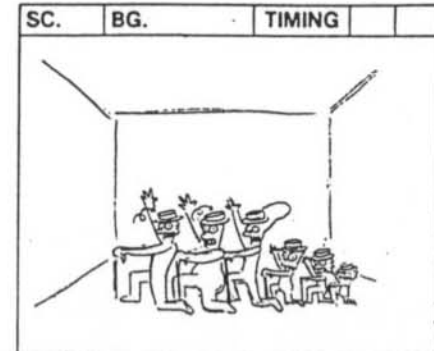
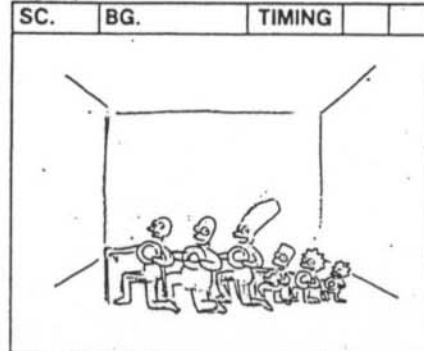

ACTION

FADE OUT:

THE END

TRANS.

DIAL

Every move-that-

we-make...

TRANS.

NOTES