

THE SIMPSONS

EPISODE #	BABF01
EPISODE TITLE	"TREEHOUSE OF HORROR"
<p>"LIFE'S A GLITCH, THEN YOU DIE" (INCLUDES: COUCH GAG)</p> <h2>ACT I</h2>	
ROUGH DRAFT	4-9-99
REVISED	4/16/99
FINAL	6/7/99

FILM ROMAN

THE SIMPSONS

TITLE _____

SHOW BABFO1

ACT 1

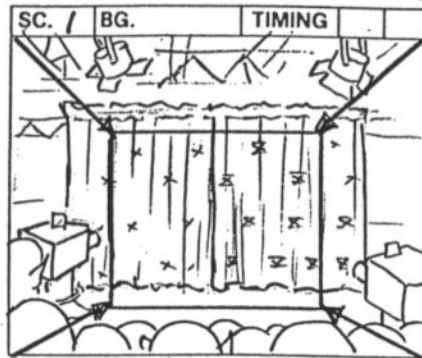
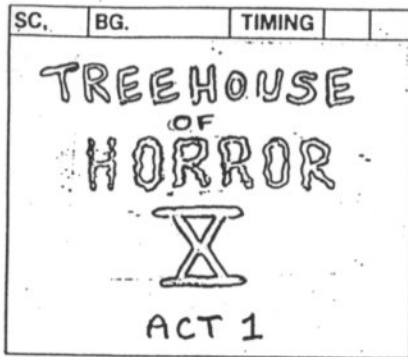

TRUCK IN TO STAGE

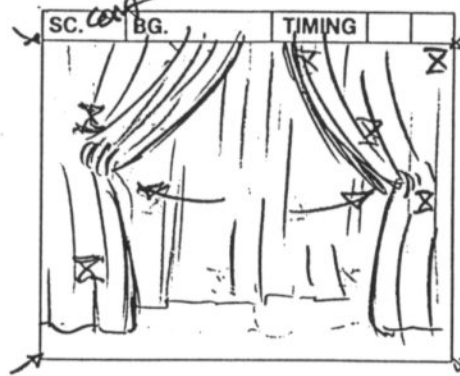

FRONT CURTAIN OPENS

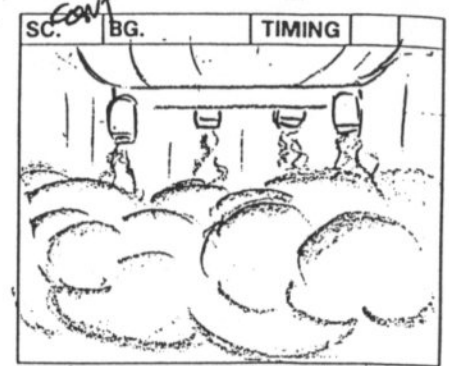

PUMPKIN DESCENDS

ACTION

WRITTEN BY RON HAUGE
DIRECTED BY PETE MICHELS
STORYBOARD BY PETE MICHELS

OPENING SEQUENCE

FADE IN:
INT. LARGE TV STUDIO - EVENING
MUSIC: TYMPANI ROLL

A giant Jack-O-Lantern spaceship, with dry-ice fog pouring out of its "landing rockets," DESCENDS to the stage.

TRANS.

MUSIC: SIMPSONS THEME LIKE A VARIETY SHOW FANFARE

DIAL

ANNOUNCER (V.O.)
Live, from fabulous Centauri City, it's

the Simpsons Tenth Halloween Special!

Now, please welcome your hosts...

TRANS.

NOTES

FILM ROMAN

THE SIMPSONS

TITLE To H I

SHOW BABFO

ACT 1

2

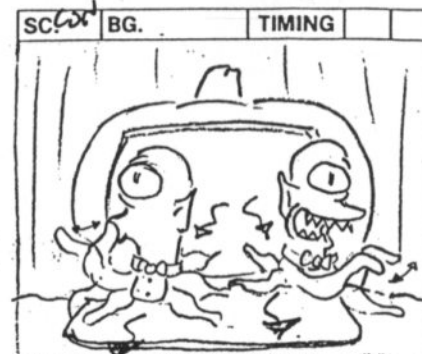
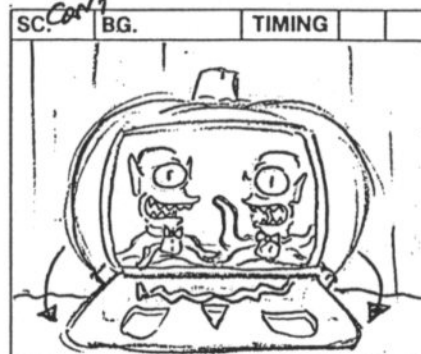
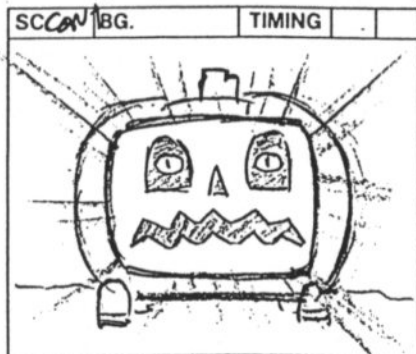
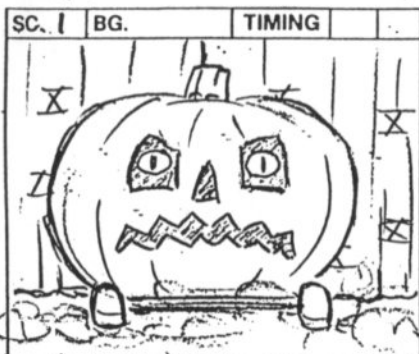

ACTION	<p>(WIDER) FADE IN EYES</p> <p>We see two big eyes appear in the pumpkin's eyeholes.</p>	<p>pumpkin opens up to reveal KANG and KODOS, wearing tuxedo collars and dickies with bow ties.</p>	<p>The</p> <p>Kang and Kodos emerge from the pumpkin and slither on stage BLOWING KISSES. Kodos does a Joan Rivers seal-like APPLAUDING motion.</p>	<p>SLITHER ALL THE WAY OUT</p>
TRANS.		<p>LIGHT STREAKS OUT AS DOOR OPENS (A LR ALIEN)</p>		<p>SFX: APPLAUSE AND CHEERS</p>
DIAL	<p>ANNOUNCER. (V.O.) (CONT'D)</p> <p>... if you haven't been probed by these</p>	<p>two, you haven't been probed...</p>	<p>Kang and Kodos!</p>	
TRANS.				
NOTES	<p>L.O. - STAGE IT SLIGHTLY WIDER</p>		<p>DIFFUSED STAGE LIGHTS →</p>	

FILM ROMAN

THE SIMPSONS

TITLE _____

SHOW BABFOI

ACT 1

F

3

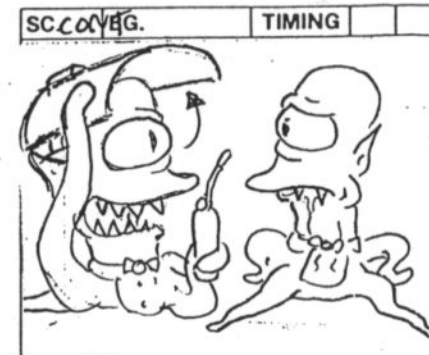
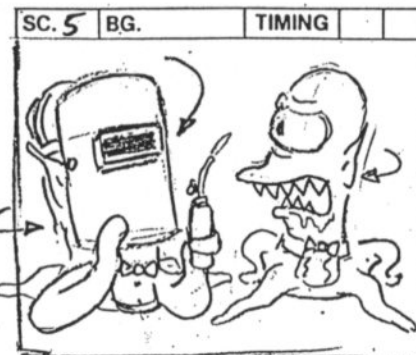
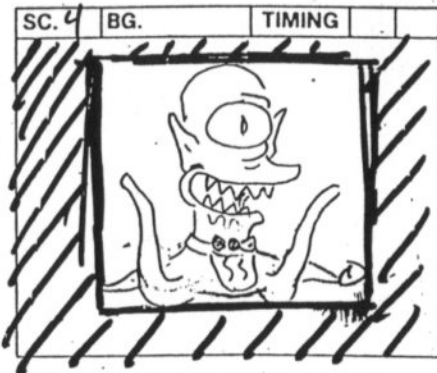
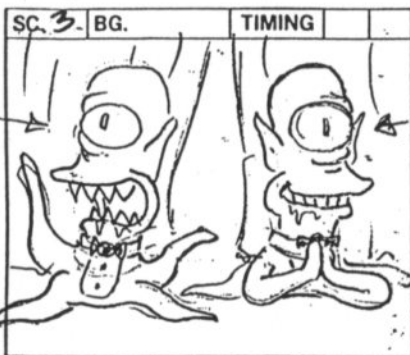

ACTION

CURTAINS CLOSE BEHIND THEM - COVERING PUMPKIN

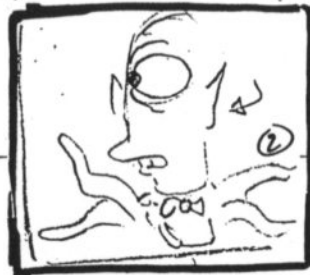

We see Kang putting on a welder's mask and LIGHTING a blowtorch.

TRANS.

DIAL

KANG
(NODDING) Thank you, thank you...

KODOS
Welcome to our Tenth Anniversary Show!

Kang,

KANG
(HOKEY) You said we were going to warm up the audience.

TRANS.

KODOS (CONT'D)
We've got a great... (DOUBLETAKE TO KANG, A LA ROWAN AND MARTIN)

what are you doing?

NOTES

TITLE _____

SHOW BABFOI

ACT 1

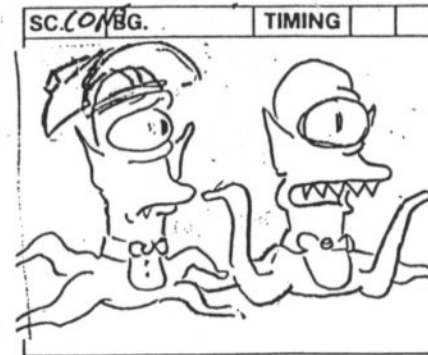
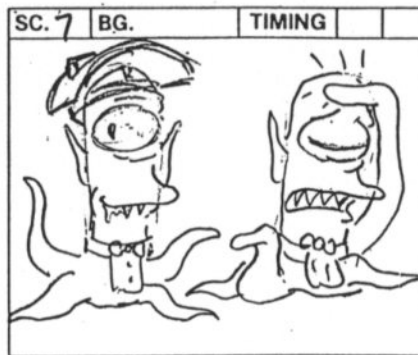
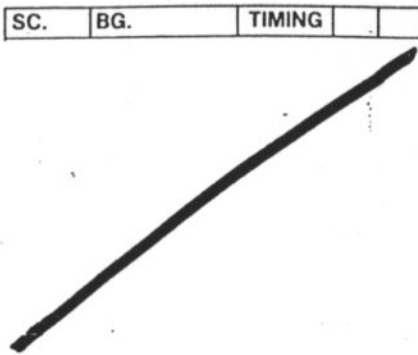
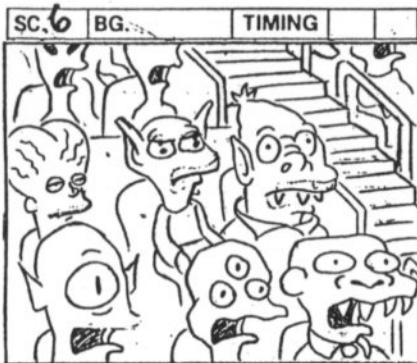

ACTION		<p>WELDER'S HELMET STILL ON</p>	
TRANS.			
DIAL		<p>KODOS Ladies and gentlemen, I have to apologize for my partner.</p>	<p>He had to borrow a human brain. ALIAN AUDIENCE (HUGE LAUGHTER AND APPLAUSE)</p>
TRANS.			
NOTES			

We CUT TO a CLOSE SHOT of part of the gruesome-looking ALIEN audience. They're not laughing. We hear LOUD CANNED LAUGHTER.

WELDER'S HELMET
STILL ON

KODOS
Ladies and gentlemen, I have to
apologize for my partner.

He had to
borrow a human brain.
ALIAN AUDIENCE
(HUGE LAUGHTER AND APPLAUSE)

TITLE _____

SHOW BABFOI

ACT 1

5

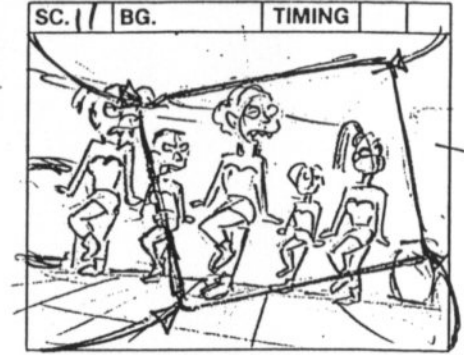
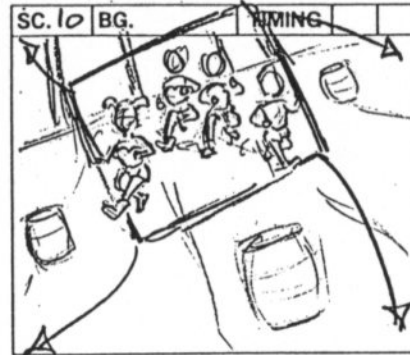
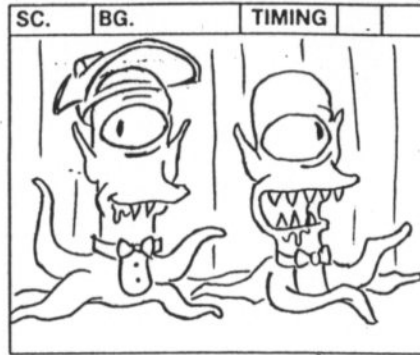

ACTION

TRUCK OUT
AS GIRLS
RUN OUT
TO DANCE

He waves on a Fly Girl-type group of ALIENS.
MUSIC: FUNXY SPACE MUSIC
SUPER: THE SIMPSONS HALLOWEEN SPECIAL X

TWIST
TRUCK IN

TRANS.

FLOOR

DIAL

KODOS
Okay, put your tentacles together for
the Solid Fuel Dancers!

TRANS.

P.11A
PAN
ACROSS FACES
DANCING



NOTES

FILM ROMAN

THE SIMPSONS

TITLE _____

SHOW BABF01

ACT 1

F

6

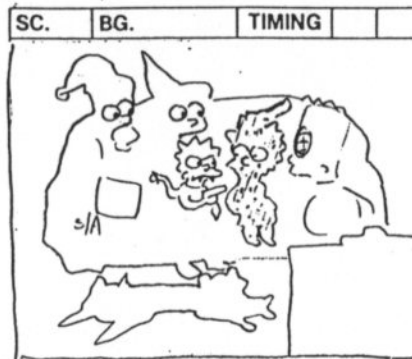
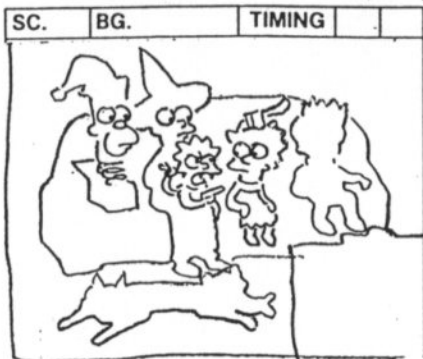
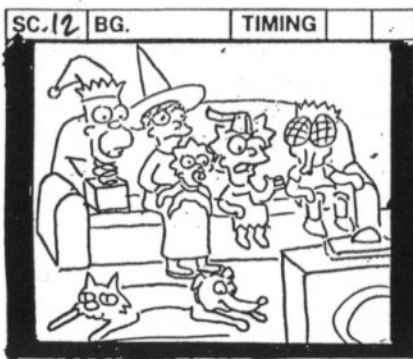

ACTION

COUCH GAG

The SIMPSONS sit on the couch. Each one is dressed like they were in a previous Halloween show. (Jack-in-the-Box Homer, Marge the witch, Fly-Head Bart, Lisa with an Itchy and Scratchy-style axe in her head, and Maggie with tentacles. The connected CAT and DOG from Halloween Special VIII lies in front of them.)

Maggie points a ray gun at Lisa and VAPORIZES her.

TRANS.

FAMILY SEES LISA VAPORIZED,
HOLD A BEAT, THEN LOOK
BACK TO TV

END OF OPENING SEQUENCE

DIAL

LISA

(CONFUSED) What do aliens have to do
with Halloween?

MAGGIE

Silence!

TRANS.

NOTES

TITLE _____

SHOW BABFO1 ACT 1 F 7

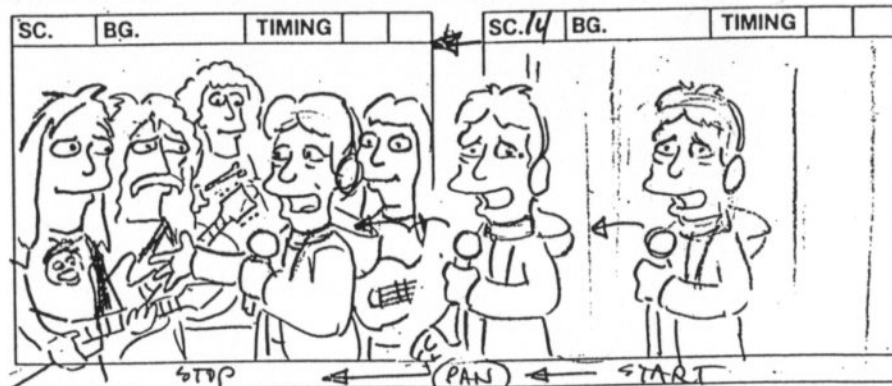
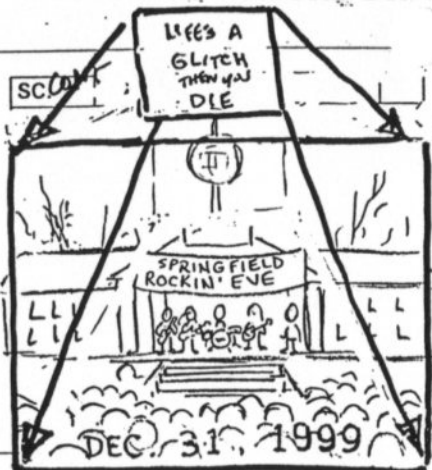
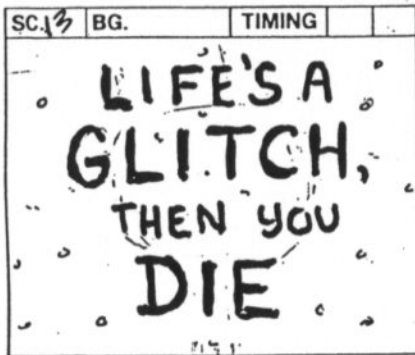

ACTION

LIFE'S A GLITCH, THEN YOU DIE
by
Ron Hauge

FADE IN:

EXT. SPRINGFIELD COURTHOUSE - NIGHT

A banner reads "Springfield Rockin' Eve." The crystal New Year's ball is mounted on a spire. DICK CLARK stands in front of a crowd of REVELERS. A HEAVY-METAL-TYPE BAND PLAYS the last chords of a song.

TRANS.

CHYRON (TYPED): DEC. 31, 1999 11:55 P.M.

DIAL

DICK CLARK

This is Dick Clark, rockin' down to the year 2000...

and that was Whitesnake!

TRANS.

NOTES

FILM ROMAN

THE SIMPSONS

TITLE _____

SHOW BABFOI

ACT 1

F

8

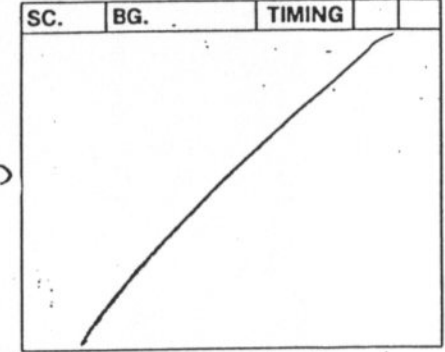
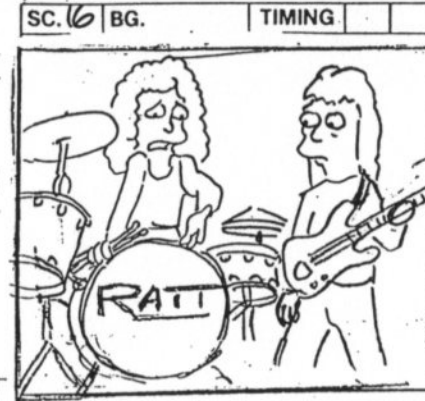
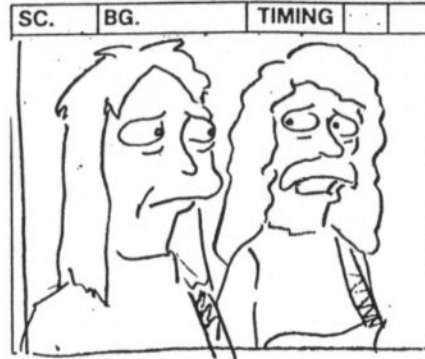
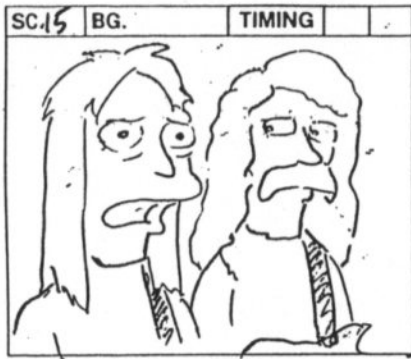

ACTION

TRANS.

DIAL

TRANS.

NOTES

		<p>Band Member #3 leans over and looks at his drums.</p>	
<p>BAND MEMBER #1 We're not Whitesnake, we're Poison.</p>	<p>BAND MEMBER #2 I thought we were Quiet Riot.</p>	<p>BAND MEMBER #3 It says here we're Ratt.</p>	

FILM ROMAN

THE SIMPSONS

TITLE _____

SHOW BABFO1

ACT 1

P. 9

SC: 17 | BG. | TIMING



SC. | BG. | TIMING

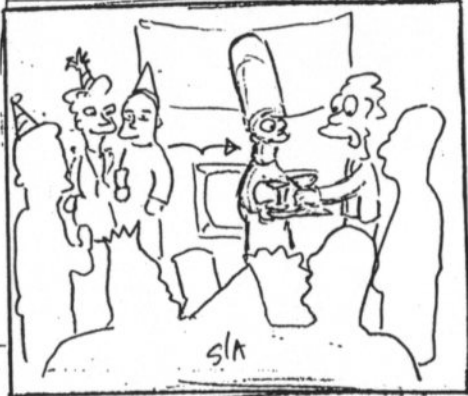

SC. | BG. | TIMING



SC. | BG. | TIMING



ACTI

MATCH TRUCK OUT
FROM T.V.

PULL BACK TO:

TRANS.

INT. SIMPSON HOUSE - TV ROOM - CONTINUOUS

MARGE is serving champagne to a crowd of Millennium's Eve PARTY GUESTS. (A banner reads, "HAPPY 2000! -- Resolve To Use Coasters!") HOMER holds a small cane-pennant that reads, "MILLENNIUM."

DIAL

TRANS.

NOTES

FILM ROMAN

THE SIMPSONS

TITLE _____

SHOW BABFOI

ACT 1

PA _____

10

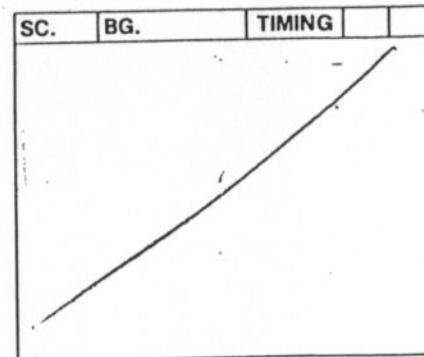
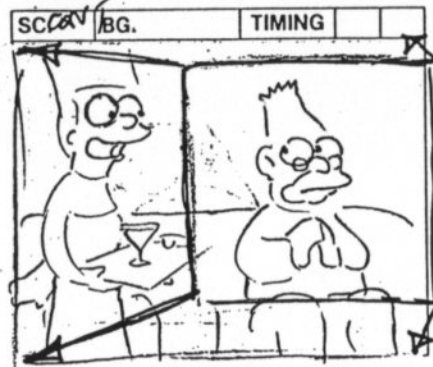
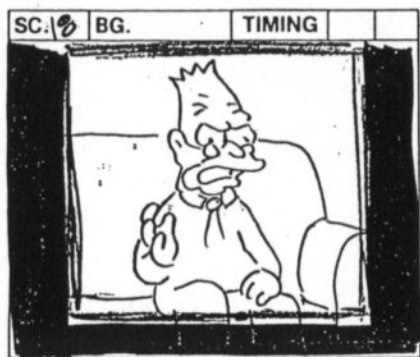

ACTION

TRANS.

AL

TRANS.

NOTES

<p>GRAMPA</p> <p>Man alive, what a stinko thousand years! Blimp wrecks, teen-agers...</p>	<p>then again, we had two good TV shows with Andy Griffith.</p>	<p>MARGE</p> <p>(HAPPILY) And eleven with Robert Urich.</p>	

FILM ROMAN

THE SIMPSONS

TITLE _____

SHOW BABFO

ACT 1

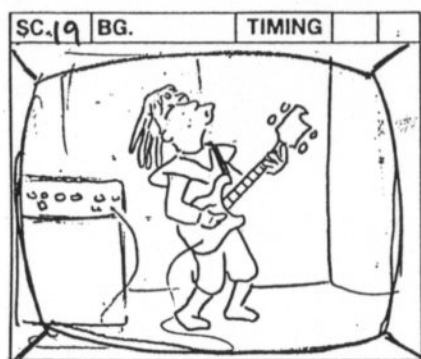

ACTION

ANGLE ON TV
RICK JAMES finishes a song.

TWO POLICEMEN grab him and escort him offstage.

DICK CAVETT IN

TRANS.

DIAL

RICK JAMES
"SUPER FREAK! YOWWWL!"

RICK JAMES (CONT'D)
What'd I do now?

DICK C.
"WONDERFUL"

TRANS.

NOTES

FILM ROMAN

THE SIMPSONS

TITLE _____

SHOW BABFO1

ACT 1

E 13

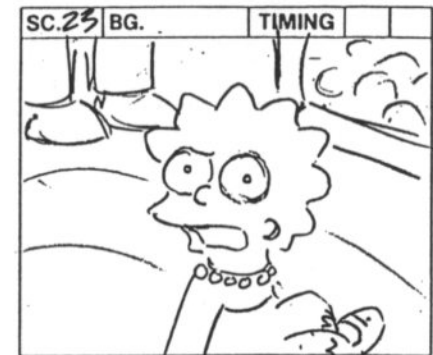

ACTION

TRANS.

DIAL

CARL
It musta been hard debugging all those computers, eh Homer?

HOMER
Doin' what now?

LISA
(TO HOMER) You did fix them, right Dad?

(OMINOUS) Because even a single faulty unit could corrupt every other computer in the world.

TRANS.

NOTES

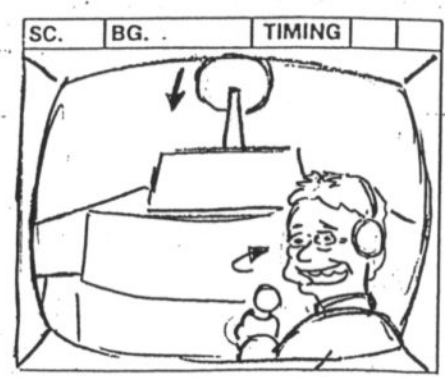
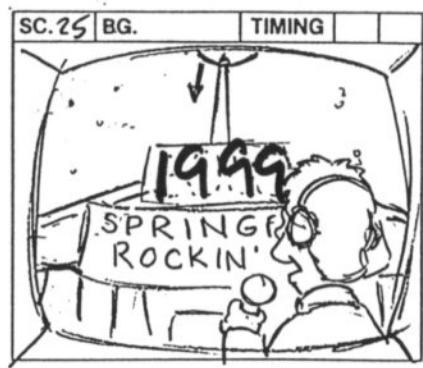
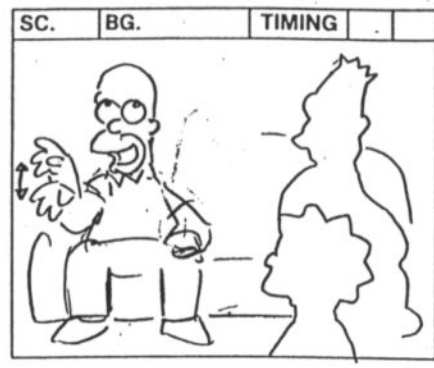
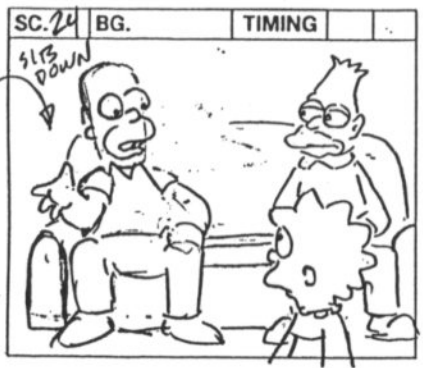

ACTION			ANGLE ON TV The New Year's Eve ball drops behind Dick Clark.	
TRANS.				
DIAL	HOMER That can't be true, honey.	If it were, I'd be terrified.	DICK CLARK (ON SCREEN) ... EIGHT... SEVEN... SIX...	we wanna thank Dixie Brand Mayonnaise...
TRANS.				Whoa Lawdy, what a mayonnaise! THREE... TWO... ONE...
NOTES				

FILM ROMAN

THE SIMPSONS

TITLE _____

SHOW BABFO1

ACT 1

P. 15

SC.26 BG. TIMING

SC.27 BG. TIMING

SC.28 BG. TIMING

SC.29 BG. TIMING

No
Sc 26-28

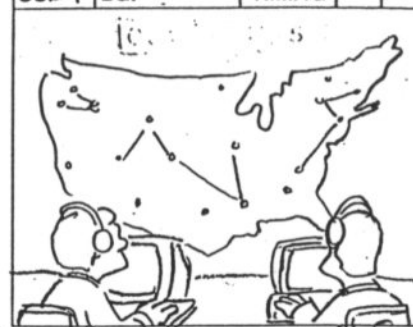

INT. HIGH TECH BUILDING - NUCLEAR
POWER MONITORING ROOM - CONTINUOUS

Two TECHNICIANS are calmly monitoring a wall display, which consists of a map of the U.S. dotted with interconnected nuclear plants (symbolized by little cooling towers).

ACTION

TRANS.

DIAL

TRANS.

NOTES

TITLE _____

SHOW BABFO1

ACT 1

F

16

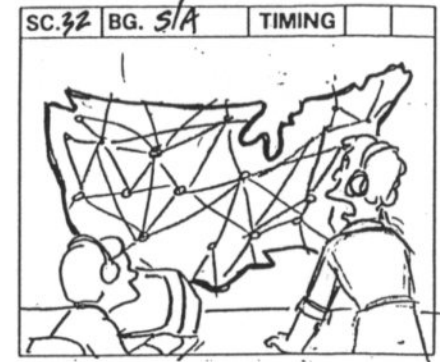
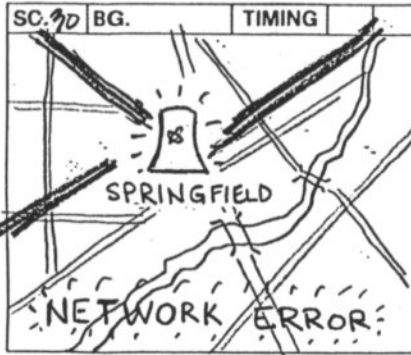

ACTION
CLOSE UP

on one of the nuclear plant symbols labeled "SPRINGFIELD". It begins to FLASH, "NETWORK ERROR" and lights radiate outward to other nuclear plant symbols.

Every plant on the map starts to FLASH, "SYSTEM CORRUPT!"

TRANS.

DIAL

TECHNICIAN #1
That's Homer Simpson's computer.

TECHNICIAN #2
Oh God! It's spreading!

TRANS.

NOTES

FILM ROMAN

THE SIMPSONS

TITLE _____

SHOW BABFOI

ACT 1

17

SC: <u>33</u>	BG.	TIMING
		
<p>ACTION</p>		
<p>TRANS.</p>		
		
<p>DIAL</p>		
<p>TRANS.</p>		
<p>NOTES</p>		

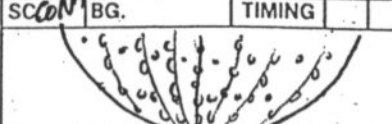
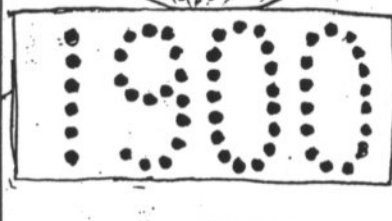
SC: <u>33</u>	BG.	TIMING
		
		

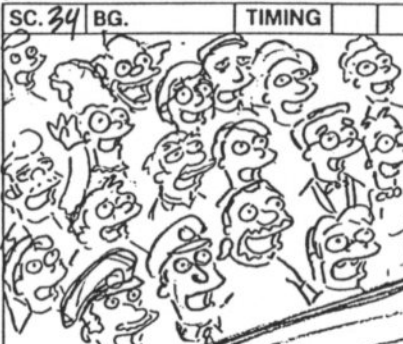
SC: <u>34</u>	BG.	TIMING
		

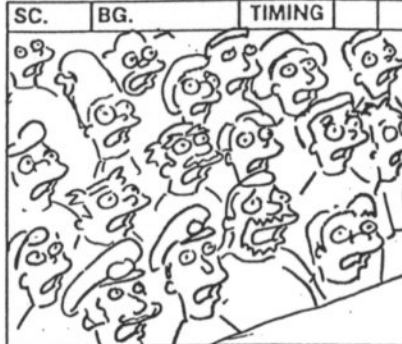
SC.	BG.	TIMING
		

EXT. SPRINGFIELD
COURTHOUSE - CONTINUOUS

The New Year's ball TOUCHES BOTTOM, and an electric sign flashes "1900!"

CROWD

Happy New -

- wha?!

TITLE _____

SHOW BABFO1

ACT 1

PA 18

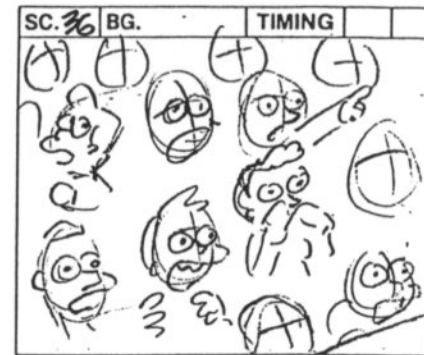
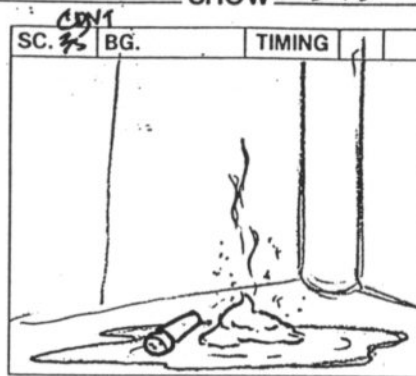
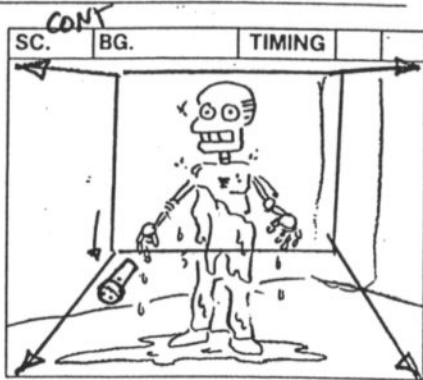

ACTION

ANGLE ON DICK CLARK
whose skin begins to age rapidly.

DROPS MICROPHONE

Within seconds his skin **MELTS** off, revealing shiny silver inner-workings. Then they **SHORT OUT** and fall to dust.

CROWD SHOT - SCREAMING

TRANS.

JIAL

DICK CLARK
(SMALL) Oh, no. It's happening.

TRANS.

NOTES

TITLE _____

SHOW BABFO ACT 1

E 19

SC.	BG.	TIMING
/		

SC.	BG.	TIMING
/		

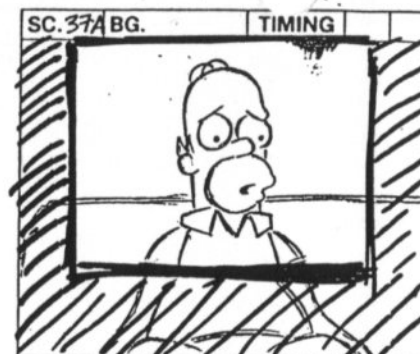
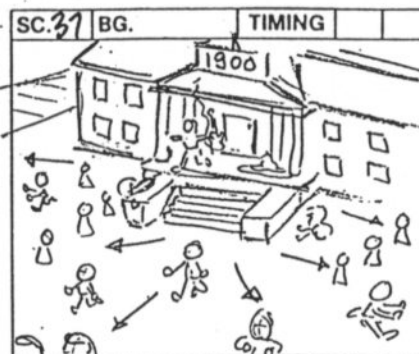

ACTION

TRANS.

DIAL

TRANS.

NOTES

		<p>The SCREAMING party crowd SCATTERS.</p>	<p>ANGLE ON HOMER</p>
			<p>HOMER (STARING AT TV) Uh-oh.</p>

TITLE _____

SHOW BABFO1

ACT 1

PAGE 20

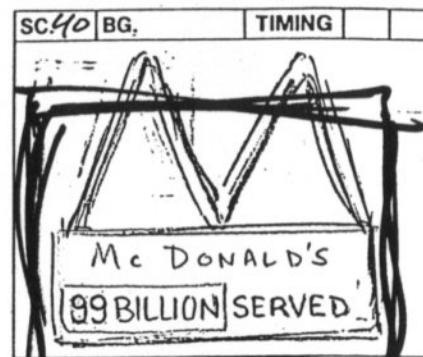
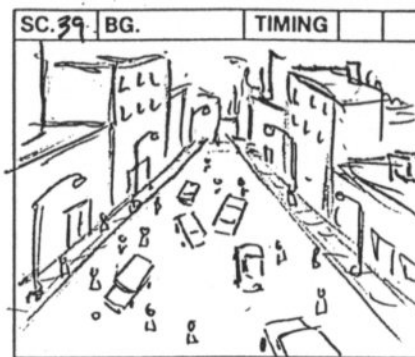
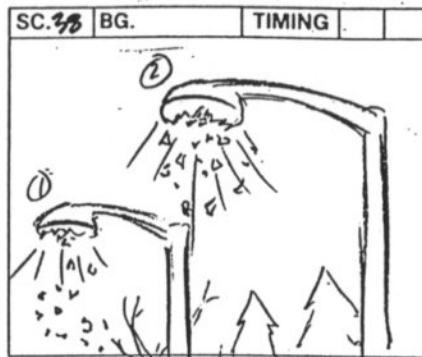

ACTION

The street lights start POPPING out as a distorted, off-key "AULD LANG SYNE" PLAYS.

Down the street, a McDonald's sign FLIPS OVER from "99 BILLION SERVED" to "ZERO SERVED."

TRANS.

DIAL

TRANS.

NOTES

TITLE _____

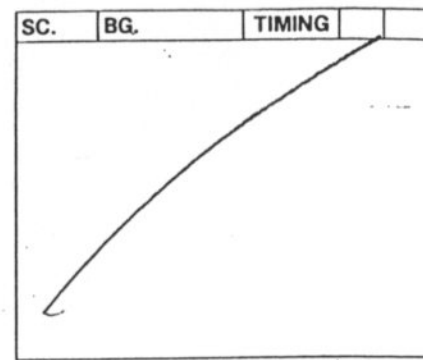
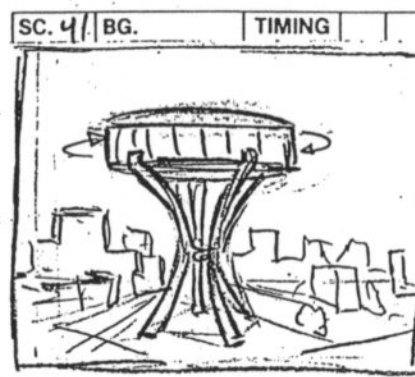
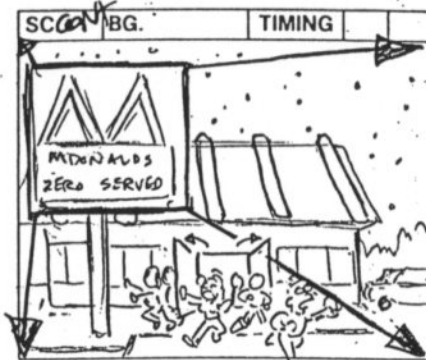
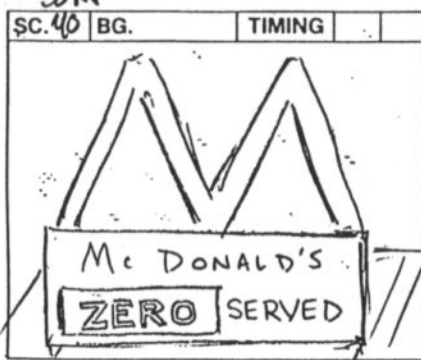

ACTION

PEOPLE STREAM OUT, terrified.

EXT. DOWNTOWN SPRINGFIELD - SIMULTANEOUS

 The city's rotating restaurant
SPINS out of control,

TRANS.

DIAL

TRANS.

NOTES

TITLE _____

SHOW BABFO1

ACT 1

PAGE 22

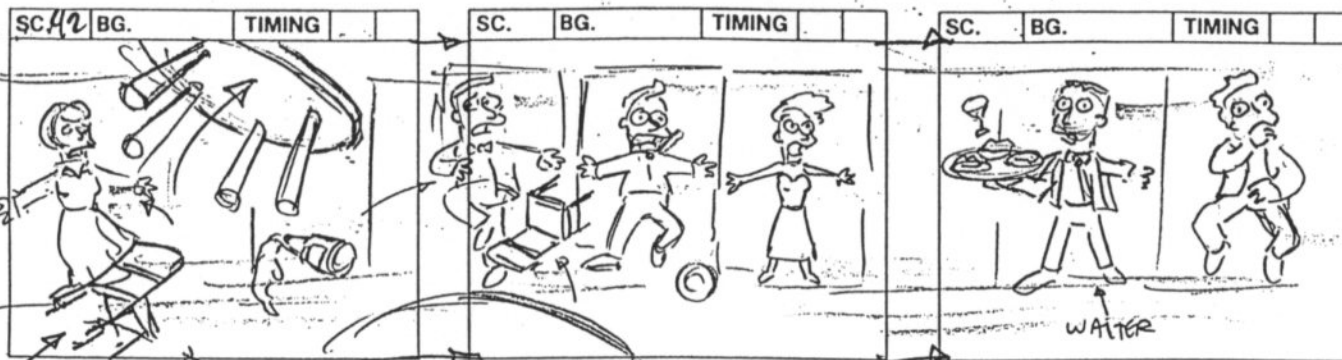

ACTION

②

← PAN QUICKLY

pinning all the SCREAMING PATRONS to the glass like a carnival ride.

TRANS

DIAL

TRAN:

① START W/ COUPLE AT TABLE — ② TABLE FLIES UP, COUPLE STICK TO WALL

NOTES

TITLE _____

	SC.	BG.	TIMING		SC.	BG.	TIMING		SC.	BG.	TIMING		SC.	BG.	TIMING		
ACTION																	
TRANS																	
DIAL																	
TRANS.																	
NOTES																	

Sc 43

Then it BREAKS LOOSE and WHIRRS OFF like a flying saucer, disappearing into the clouds.

ACTION

TRANS

DIAL

TRANS.

NOTES

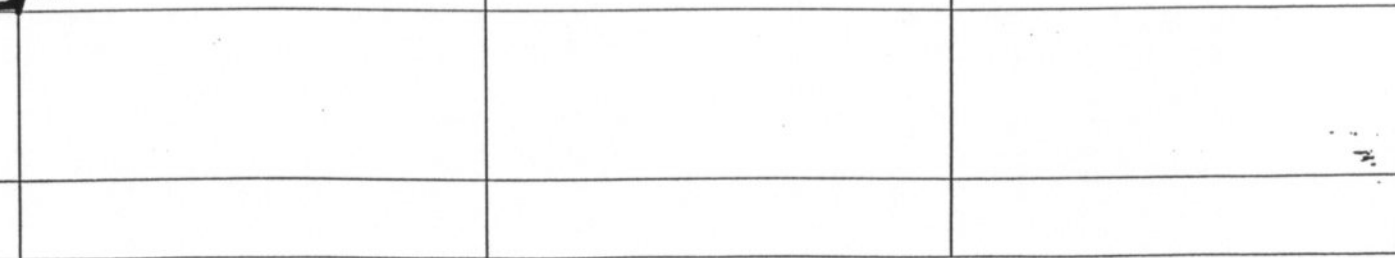
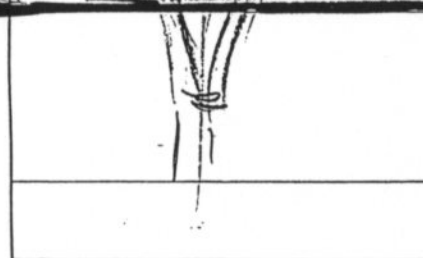
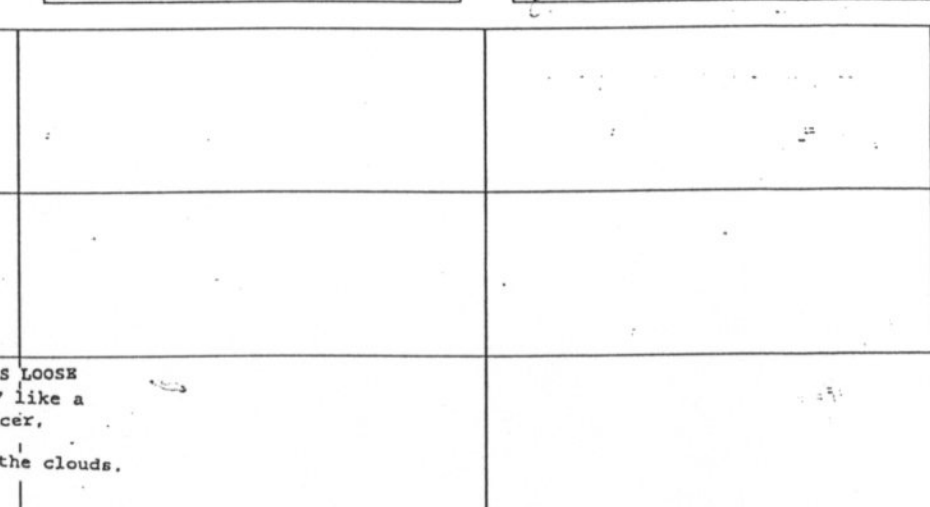
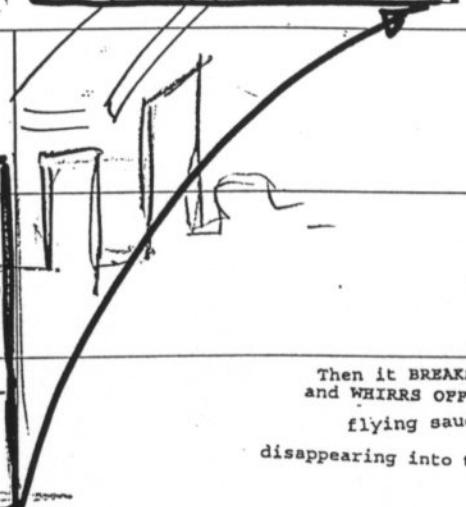
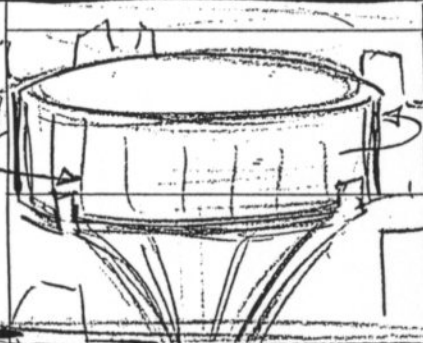
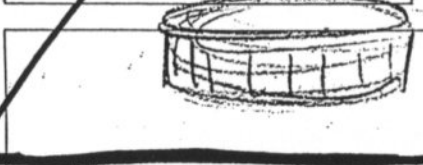
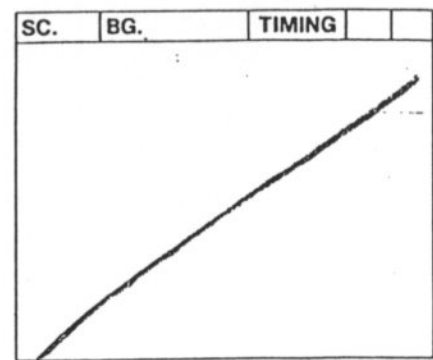
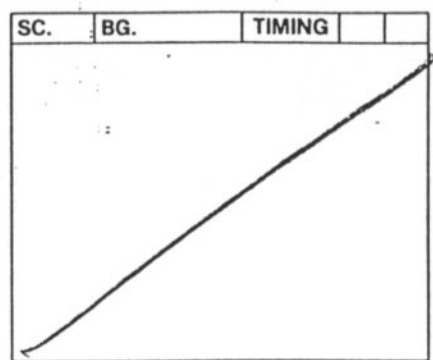
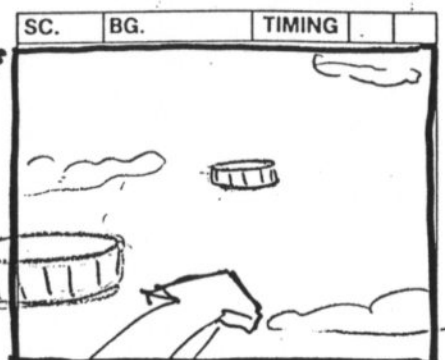
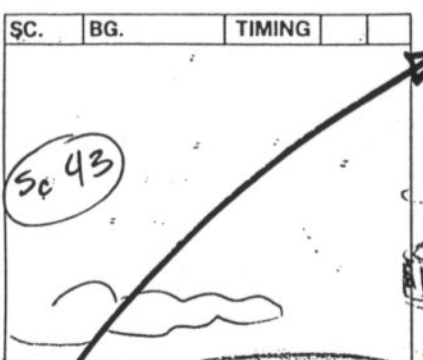

TITLE _____

SHOW BABFO1

ACT 1

E

22B



ACTION

INT. KWIK-E-MART - SIMULTANEOUS
A perplexed APU is working the Squishee machine for CHIEF WIGGUM.

TRANS.

DIAL

APU
The only flavors available right now, apparently, are fire and blood, sir.

CHIEF WIGGUM
(CONSIDERING NOISE) Blood.

(SUDDENLY
PANICKED) No, no!

TRANS.



NOTES

old sc. 63

old sc. 64

old sc. 65

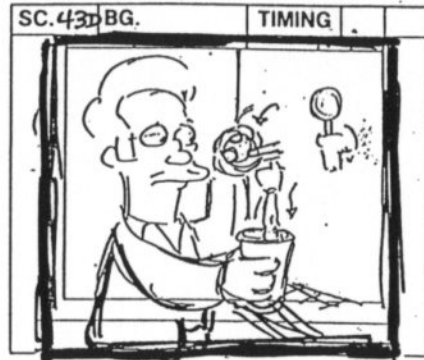
TITLE _____

	SC. 43c	BG.	TIMING	SC. 43d	BG.	TIMING	SC.	BG.	TIMING
									
ACTION				Apu DRAW S a cup of blood,			then gives it a SPRITZ of flame.		
TRANS.									
DIAL	Half and half.								
TRANS.									
NOTES	old sc. 6S			old sc. 6G					

FILM ROMAN

THE SIMPSONS

TITLE _____

SHOW BABFD1 ACT 1

22D

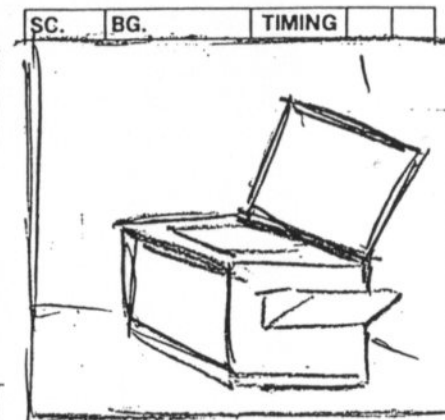
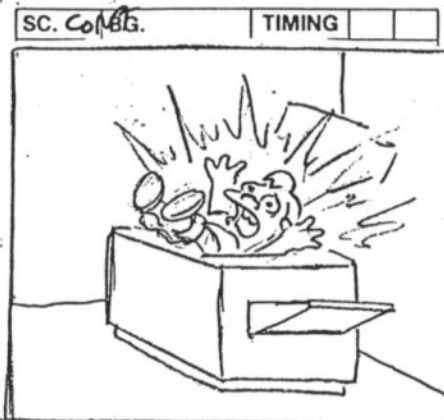
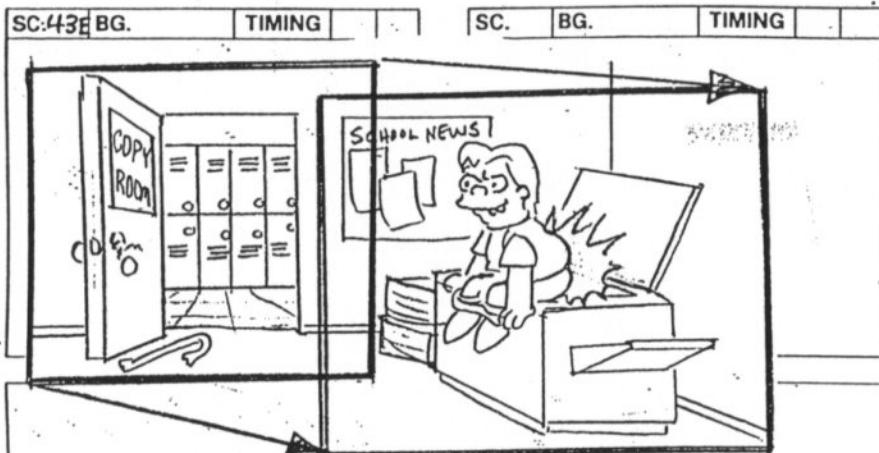

ACTION

The light FLASHES, and Nelson is SUCKED into the machine.

TRANS.

INT. SPRINGFIELD ELEMENTARY -
COPY ROOM - SIMULTANEOUS

The copy room door has been jimied open. NELSON is sitting on the Xerox machine, copying his butt.

DIAL

NELSON (O.S.)
(DISAPPEARING) ... Wha?!

NELSON

Ha...

TRANS.

Sc 43F



NOTES

old sc. 67

old sc. 68

TITLE _____

SHOW BABFOI

ACT 1

SCENE _____

23

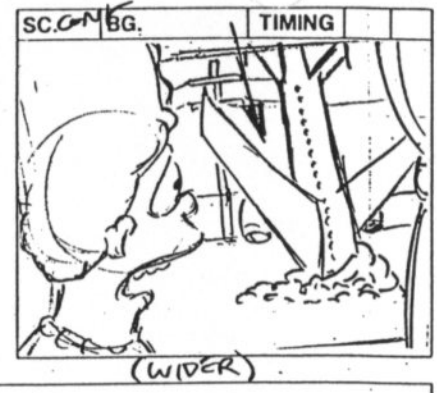
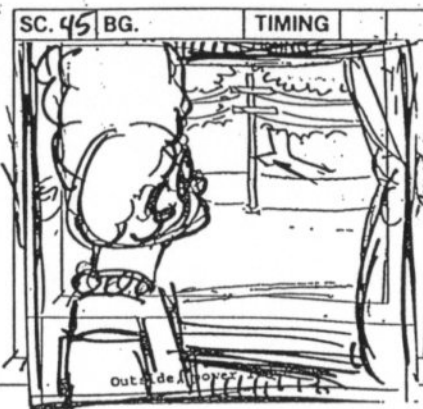
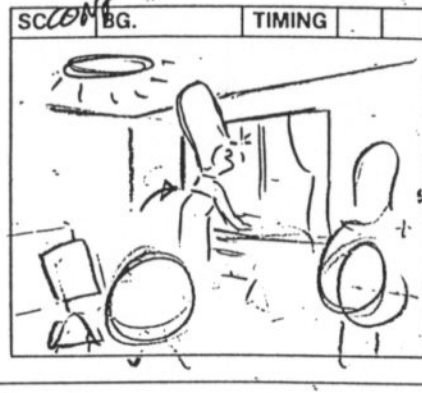
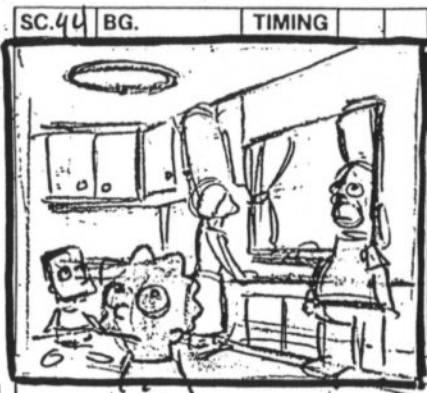

ACTION

The house lights FLICKER as the family looks out the window warily.

Outside, power lines ARC.

A jet PLUNGES straight down into the backyard.

TRANS.

INT. SIMPSON HOUSE

SEVERAL SETS ALREADY THERE

DIAL

MARGE

TRANS.

(CONCERNED MURMUR) Who's going to clean up all those jets?

NOTES

TITLE _____

SHOW BABFOI ACT 1

PAGE 24

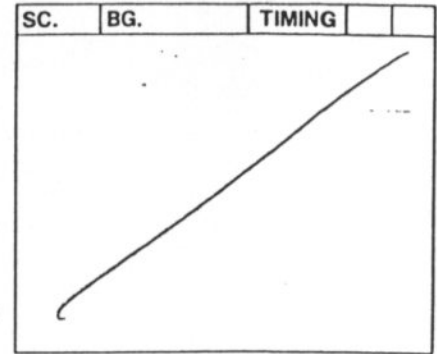
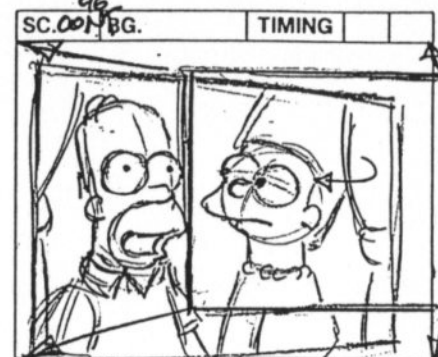
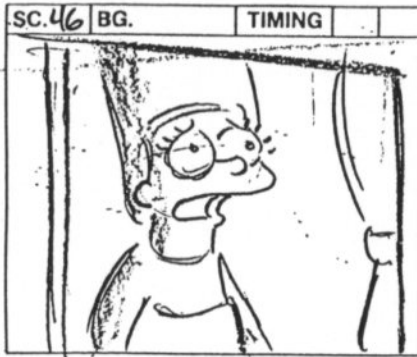

ACTION

	We hear another jet FALL off screen.		Homer enters with a ridiculously chipper smile.
TRANS.			
DIAL		There goes the clothesline.	HOMER Well, those ivory tower eggheads have screwed us again, heh, heh.
TRANS.			
NOTES			

TITLE _____

SHOW BABFOI

ACT 1

E

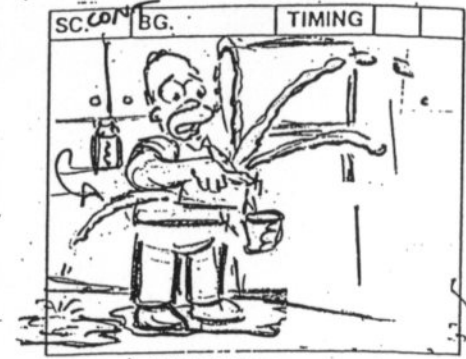
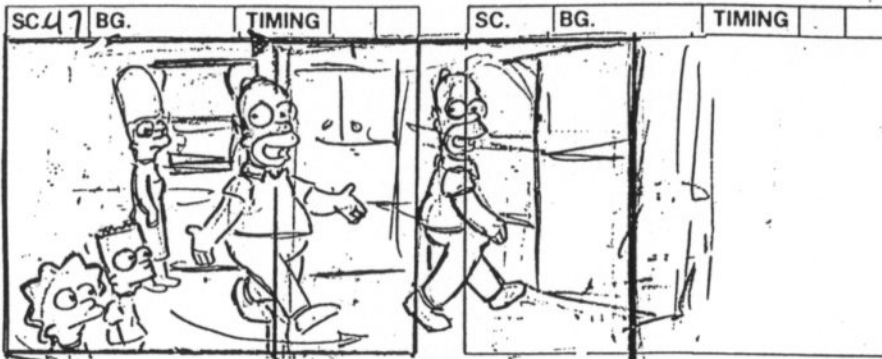

ADJUST

ACTION

INT.
KITCHEN — HOMER WALKS TO FRIDGE

Homer tries to pour milk from a carton. The carton SPUTTERS and SPEWS messy jets of milk.

TRANS.

DIAL

Let's just
have some milk and go to bed...

HOMER (CONT'D)

Hey, this milk's broken.

TRANS.

NOTES

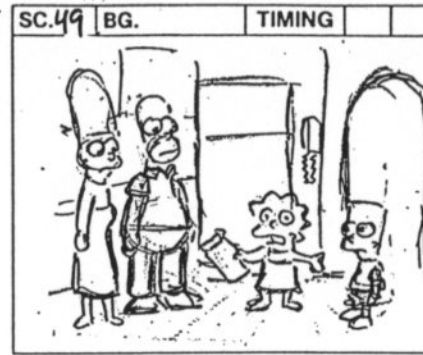
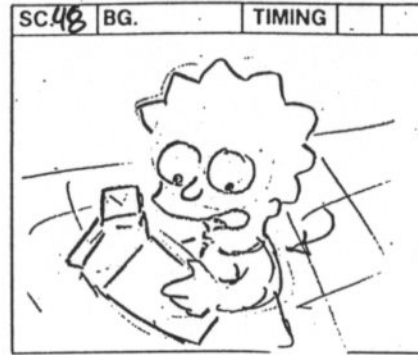
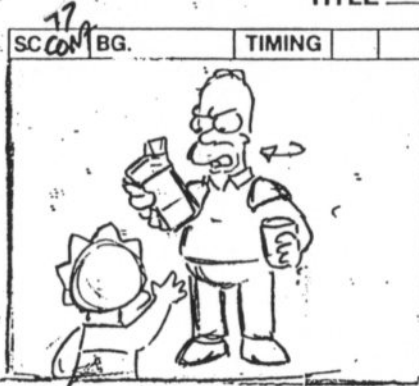

ACTION	LISA IN, GRABS CARTON		REACT TO NOISE (MICROWAVE)
TRANS.			
DIAL		LISA (EXAMINING CARTON) It's got a computer chip in it.	Everything does.
TRANS.			
=NOTES			

TITLE _____

SHOW BABFOACT 1

PA _____

27

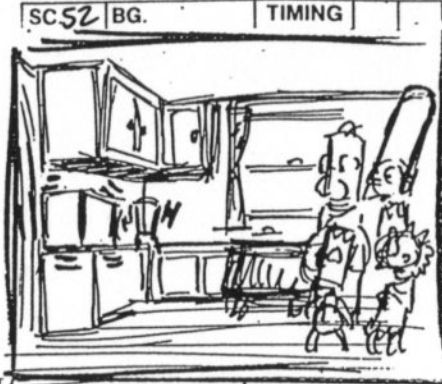
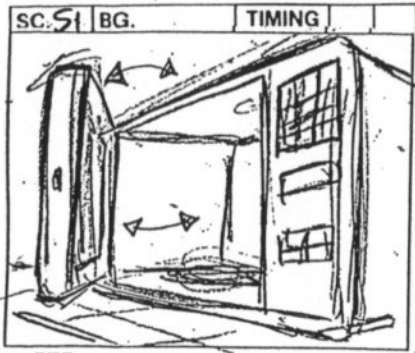

ACTION.

The microwave door
starts OPENING and CLOSING.

The blender
STARTS UP and CLATTERS
around on the counter.

TRANS.

IAL

TRANS.

NOTES

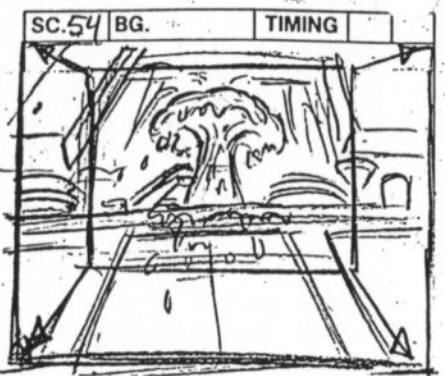
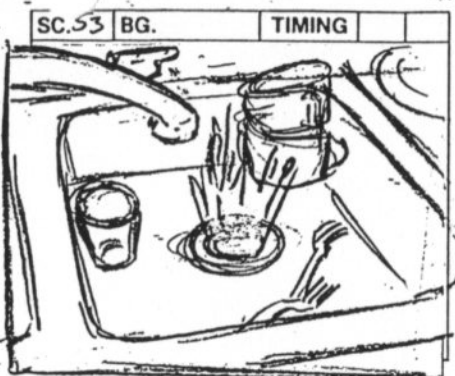

NO
SC 55-58

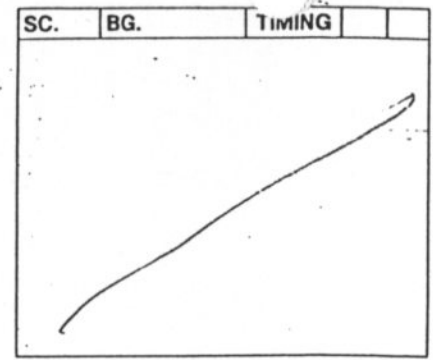

ACTION	EARTHQUAKE-LIKE CAMERA SHAKE CUT ON ACTION	A small geyser of garbage SHOOTS out of the garbage disposal.	
TRANS.			
DIAL			
TRANS.			
NOTES			

SC 59

TITLE _____

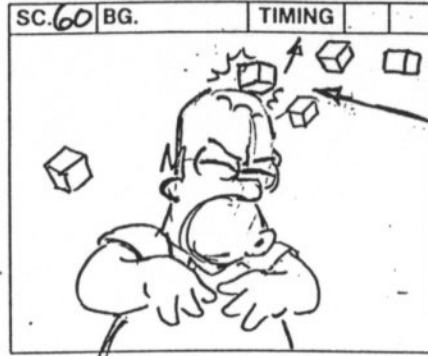
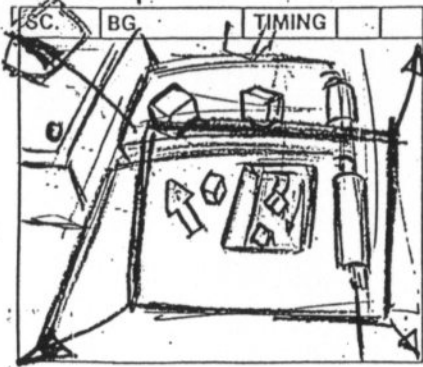

SC.	BG.	TIMING

ACTION

QUICK PULL OUT
w/ ICE CUBES

The automatic icemaker in the refrigerator door starts SHOOTING cubes at the family, HITTING Homer in the head several times.

REACTS TO O.I.S.
WAFFLE IRON

TRANS.

DIAL

HOMER

Stop! Ow! (PAINED SOUNDS)

TRANS.

--NOTES

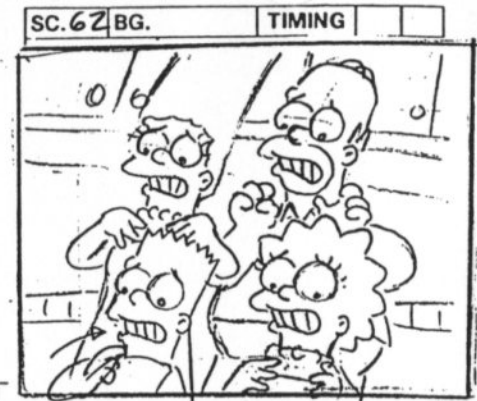
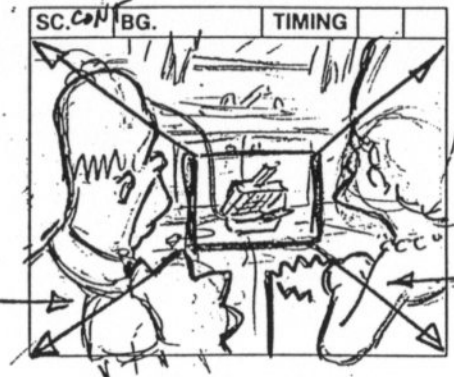
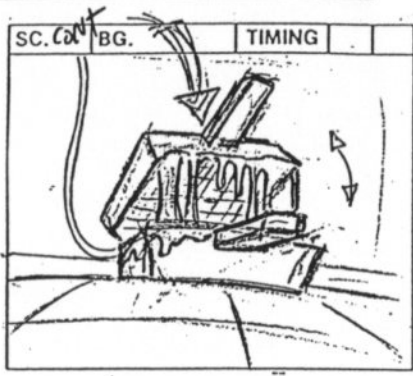
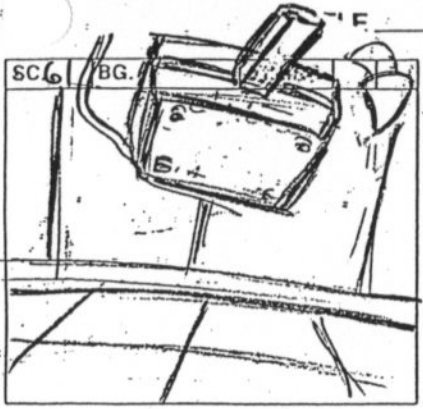

ACTION

The waffle iron (still plugged in) advances, **SNAPPING** like an alligator and **STEAMING**. Waffle mix **DRIPS** from its maw like "Alien" goo.

PULL OUT —
PAN IN FAMILY

TUG AT COLLARS

TRANS.

DIAL

HOMER/MARGE/BART/LISA
(CHARLES NELSON REILLY NOISES)

TRANS.

NOTES

FILM ROMAN

THE SIMPSONS

TITLE _____

SHOW BABFO1

ACT 1

36

*
ND
SC
63-68

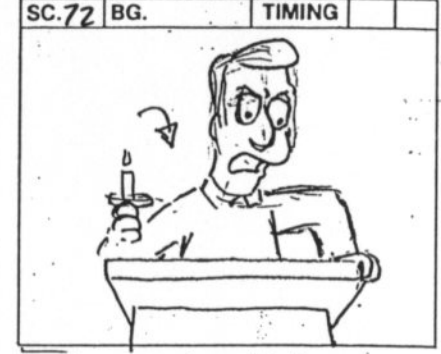
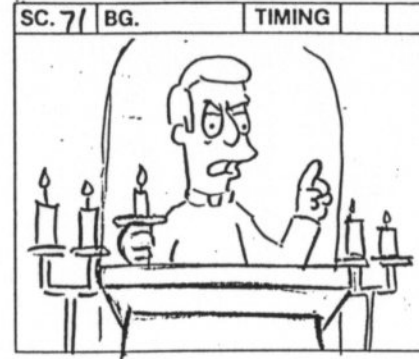
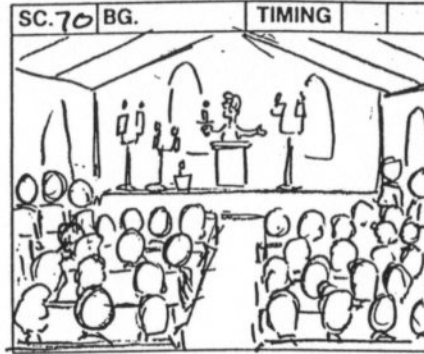
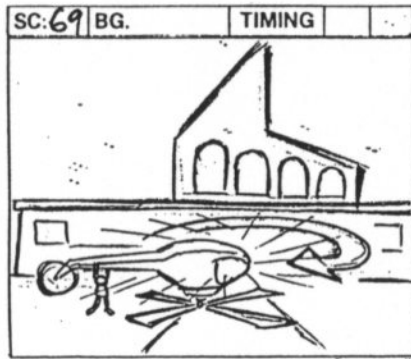

ACTION

On the church lawn,
an upside-down helicopter SPINS
around wildly as its rotor
remains embedded in the ground.
(Its rotor doesn't move.)

INT. SPRINGFIELD CHURCH - CONTINUOUS

The crowded church is lit by candles. There's doom in the
air as REV. LOVEJOY speaks.

TRANS.

ARNIE PIE hangs on for dear life
to the spinning tail.

DIAL

ARNIE PIE
(QUICK DOPPLER YELPS)

REV. LOVEJOY
Judgment Day is upon us.

I
warned you the Lord wouldn't stand for
your mini-dresses, and Beate boots,
and

instant coffee...

TRANS.

NOTES

TITLE _____

SHOW BABFO1 ACT 1 F 37

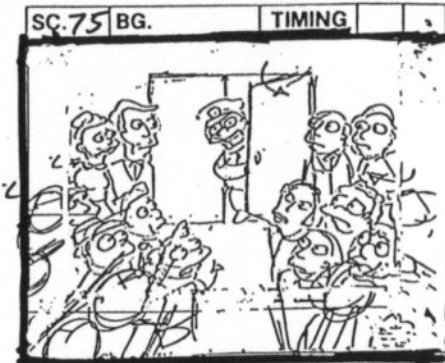

ACTION	<p>We see NED FLANDERS frantically trying to unzip his Beate boots.</p>	<p>"</p>	<p>"</p>	<p>We see Chief Wiggum at the church door.</p>
TRANS.				
DIAL	<p>FLANDERS I resisted these for thirty-five years! Why did I wear them today?</p>	<p>REV. LOVEJOY But it's not too late to repent your sins and be</p>	<p>embraced by the Almighty --</p>	<p>CHIEF WIGGUM They're looting the mall.</p>
TRANS.			<p>CHIEF WIGGUM (O.S.) Hey, everybody!</p>	
NOTES				

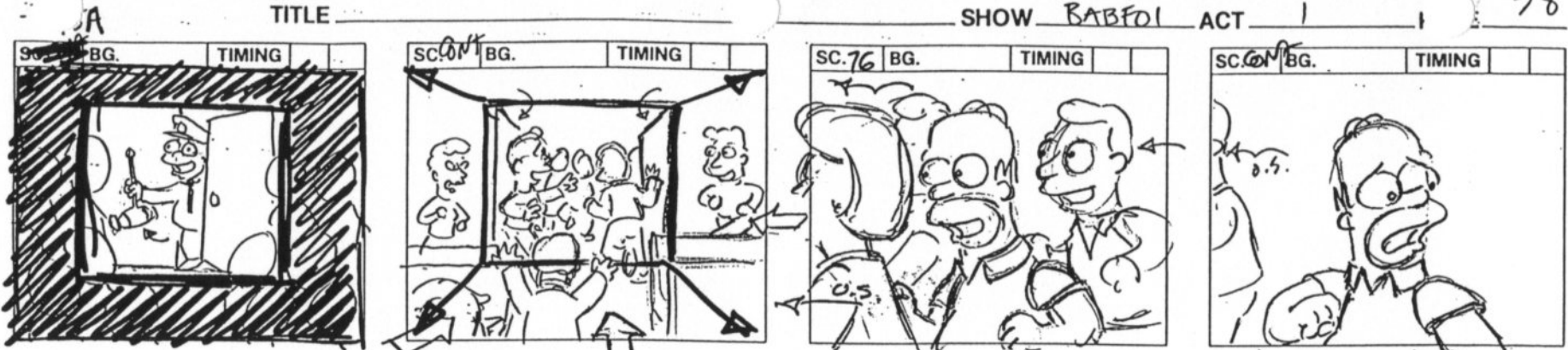

ACTION

CUT CLOSE

THEN PULL OUT

Everybody CHEERS and RUNS out. Homer tries to run, but can't move.

 STRUGGLES A
BEAT

TRANS.

DIAL

CHIEF WIGGUM

Hurry!

I got nine shoe buffers!

HOMER

 (STRUGGLING SOUND) I'm caught on
something!

TRANS.

NOTES

CONT

TITLE _____

SHOW BABFOI

ACT _____

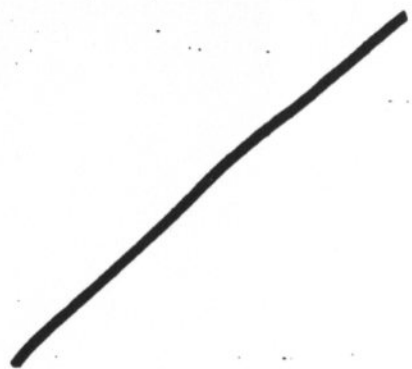
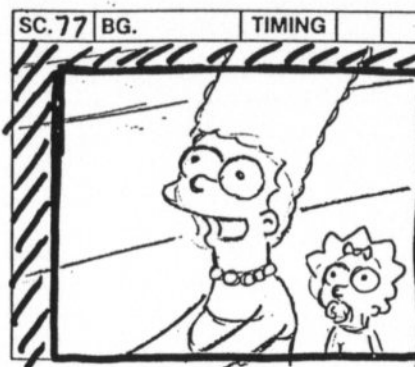
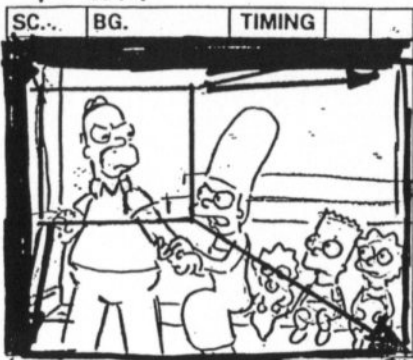

ACTION

We WIDEN to see Marge is holding him by the arm.

TRANS.

DIAL

MARGE
I don't want you looting!

HOMER
But I was gonna loot you a present!

MARGE
(TOUCHED) Oh, all right.

TRANS.

NOTES

TITLE _____

SHOW BABFDI

ACT 1

PAGE _____

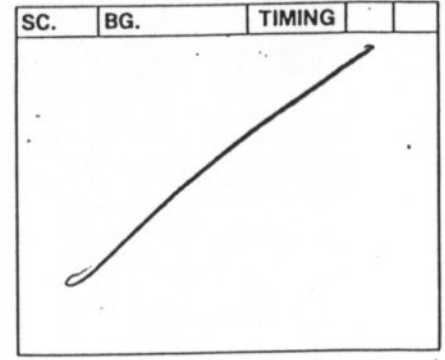
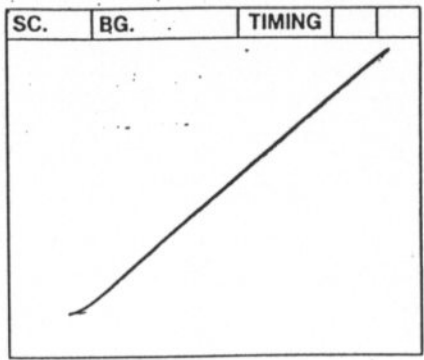
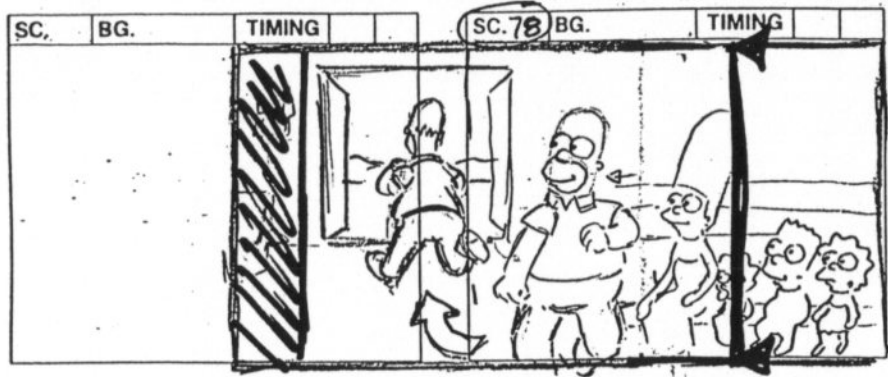

ACTION

She lets go of Homer and he runs out to join the looters.

TRANS.

DIAL

HOMER
(HAPPY SOUND)

TRANS.

NOTES

TITLE _____

SHOW BABFOI

ACT 1

GE 42



START → PAN WITH SHOPPING CART → STOP

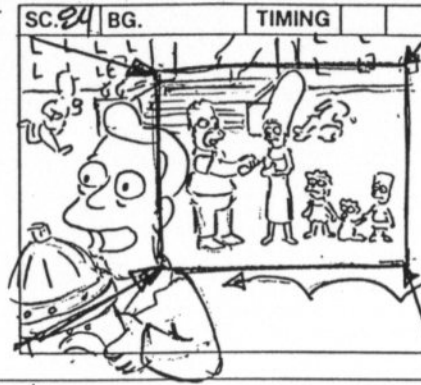

ACTION	<p>MORNING (PINK SKY) In the background we see people looting and pushing shopping carts full of looted food and clothes.</p>		<p>Marge opens a small box.</p>
TRANS.	<p>DOLPH, JIMBO, KEARNY RUN OUT OF GOLF STORE WITH CLUBS + GOLF HIATS</p>		
DIAL			<p>MARGE Oh, thank you, Homie.</p>
TRANS.			
NOTES			

Cont TITLE SHOW BABFO1 ACT PAGE

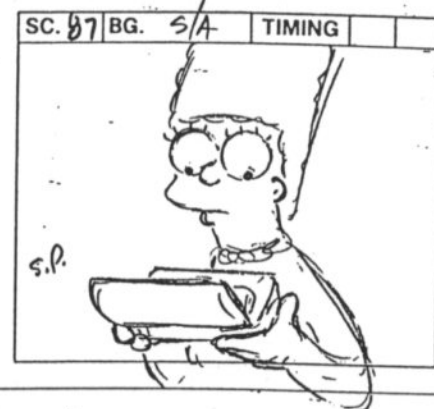
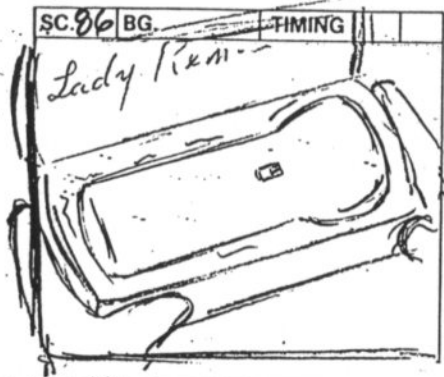

ACTION
 TRANS.
 DIAL
 TRANS.
 NOTES

STARTS VIBRATING IN BOX		A LADY REMINGTON jumps out of the box and ATTACKS Marge's throat.	
(MARGE CONT) A Lady Remington.			

FILM ROMAN

THE SIMPSONS

TITLE _____

SHOW BABFO1

ACT 1

PAGE 51

NOON

MULTI-PLANE PAN UP

ACTION

TRANS.

DIAL

TRANS.

NOTES

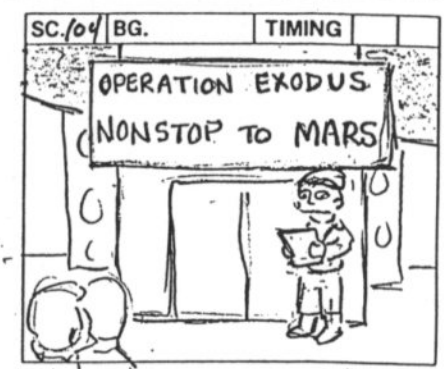
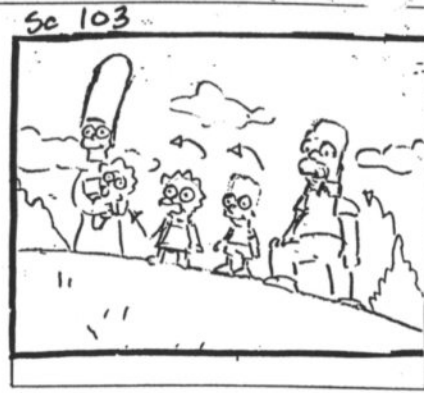
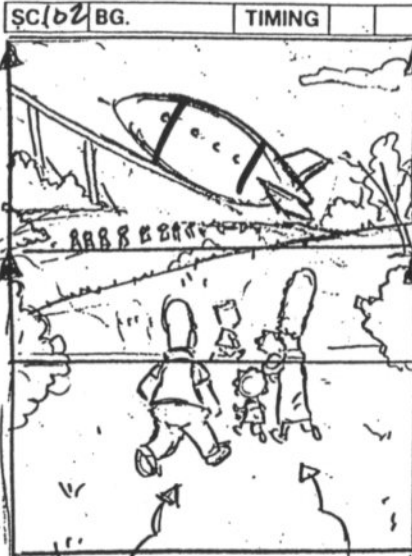

EXT. SPRINGFIELD - GRASSY HILLTOP - NOON
 The family comes over a rise and sees a huge, gleaming, American-built spaceship on a launch pad.

Homer runs toward the spaceship and the family runs after him.

EXT. SPACESHIP LAUNCH AREA - DAY - A FEW MINUTES LATER
 We open on the spaceship that has a sign over the open door that reads "Operation Exodus/Nonstop to Mars".

LISA
 There it is. (SOLEMN) The last glimmer of hope for the future of mankind.

I call window seat!

TITLE _____

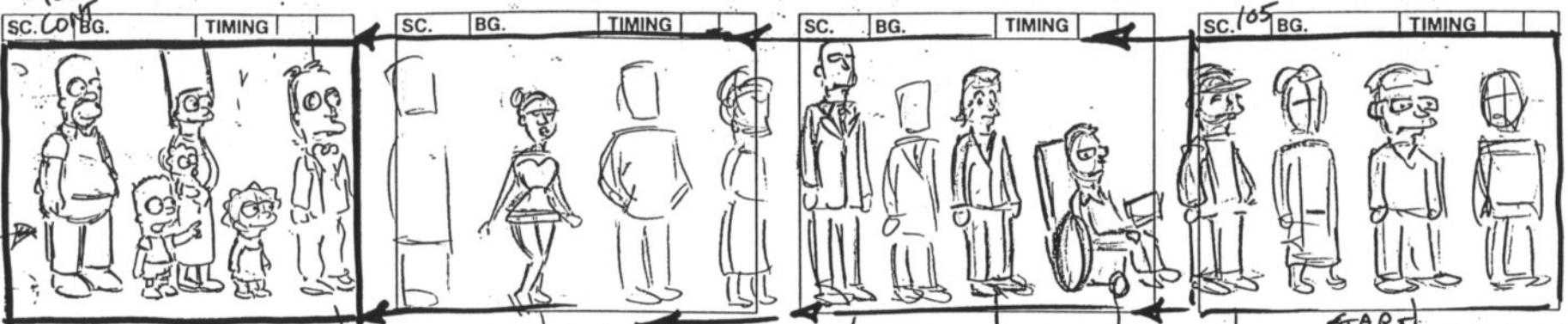



ACTION	STOP	FRINK	MICHELE KWAN	PAN	MICHAEL JORDAN	PAUL MCCARTNEY	STEPHEN HAWKING	RON HOWARD	BILL GATES
TRANS.	At the end of the line are the Simpsons. (The line moves forward during the next exchange.)			(Other famous people on line can include Mel Gibson, Ron Howard, Mark McGwire, Jimmy Carter, Prof. Frink, Steven J. Gould, and Joe Namath.)					
DIAL	BART								
TRANS.	Wow, there's Bill Gates, Stephen Hawking, Paul McCartney, Michael Jordan, Michelle Kwan...								
NOTES									

FILM ROMAN

THE SIMPSONS

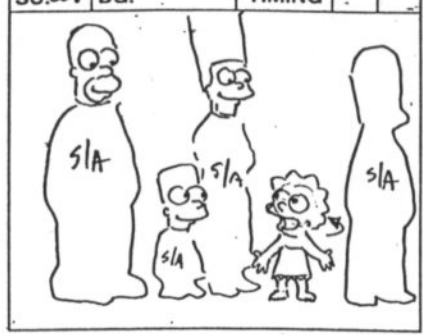
SHOW BABFOI ACT 1 E 56A

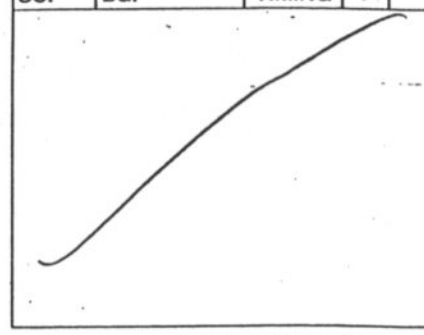
UNT		TITLE		SC. 105		BG.	TIMING		
									
									
									
									
ACTION									
TRANS.									
DIAL	LISA		civilization on Mars with our best and brightest.			HOMER		That's us!	
TRANS.									
NOTES									

TITLE _____

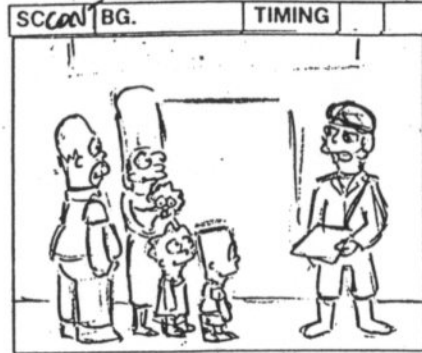
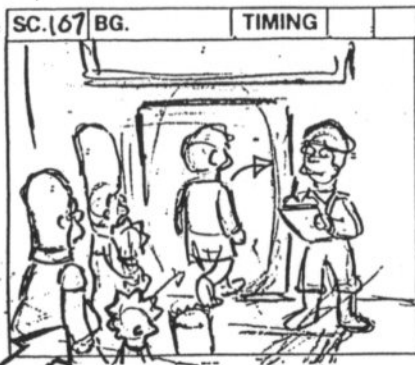

ACTION	They reach the door of the spaceship.		
TRANS.			
DIAL	GUARD Name please.	HOMER Certainly. (LYING) I am... the piano genius from the movie "Shine."	GUARD (SKEPTICAL) And your name is?
TRANS.			
NOTES			

TITLE _____

SHOW BABFOI ACT 1

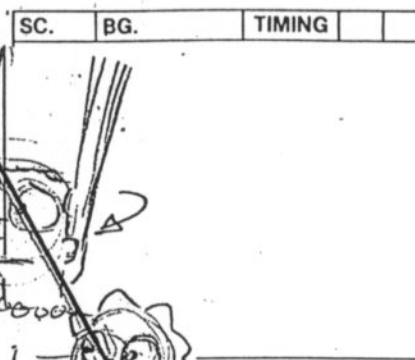
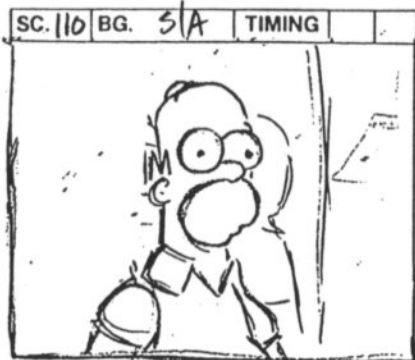

ACTION

TRANS.

DIAL

TRANS.

NOTES

	<p>HOMER</p> <p>(CAUGHT) Uh... Shiny McShine (PAUSE)</p> <p>Shine?</p>	
	<p>LISA</p> <p>Actually, he's Homer Simpson. That's</p> <p>Bart. I'm Lisa...</p>	<p>GUARD</p> <p>(CHECKING CLIPBOARD) Lisa Simpson?</p>

TITLE _____

SHOW BABFOI

ACT 1

SCENE _____



ACTION

TRUCK IN AS HE KNEELS

She starts to enter, but he stops her.

TRANS.

DIAL

You're the ship's proofreader.

Welcome aboard!

GUARD (CONT'D)

Now before you enter,

you're going to have to make a very difficult choice. You're only allowed to take one parent with yo --

TRANS.



Ref. Pos.

NOTES

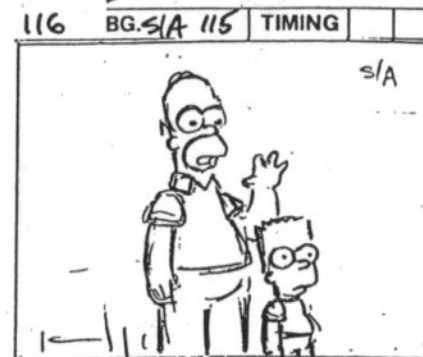

ACTION

Lisa and Marge (carrying Maggie) board the ship.

TRANS.

DIAL

LISA
(QUICKLY) Mom.

MARGE
(WAVES TO BART AND HOMER, QUICKLY)
Love ya lots!

HOMER
(SWEETLY) Good-bye Lisa, remember me
as I am...

TRANS.

NOTES

FILM ROMAN

THE SIMPSONS

TITLE THOH #8 SHOW BABF01 ACT 1 E 61

3A

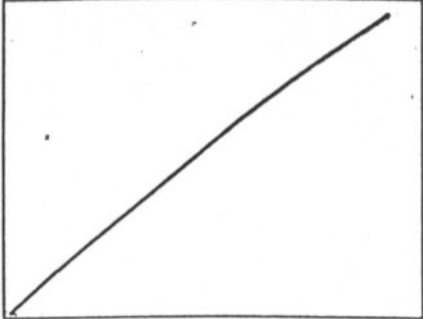
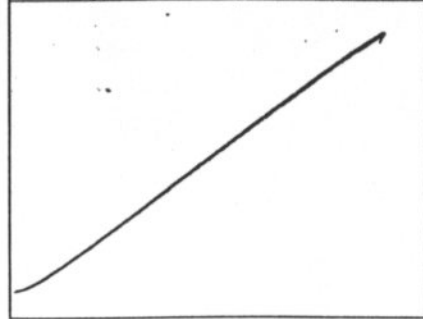
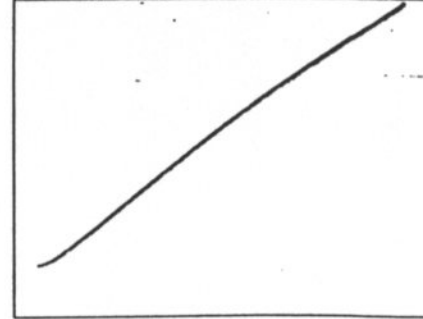
	SC.	BG.	TIMING			SC.	BG.	TIMING			SC.	BG.	TIMING			SC.	BG.	TIMING		
																				
ACTION																				
TRANS.																				
DIAL	(BITTER) filled with murderous rage.																			
TRANS.																				
NOTES																				

6B

TITLE _____

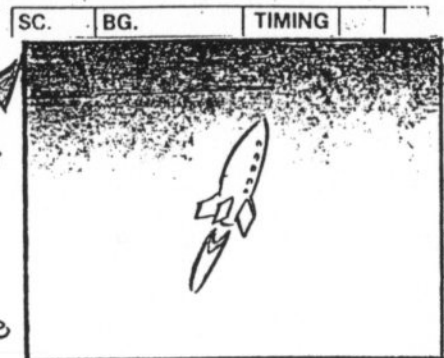
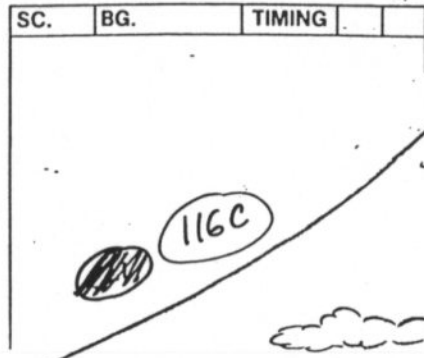
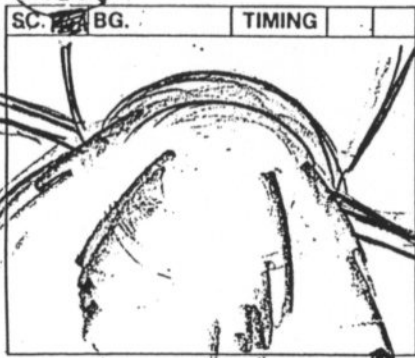

ACTION

CUT ROCKET
ENGINES FIRE

TRANS.

DIAL

TRANS.

-NOTES

WAS SC 120

WAS SC 121

FILM ROMAN

THE SIMPSONS

62A

TITLE _____

SHOW BABFOI ACT 1 E _____

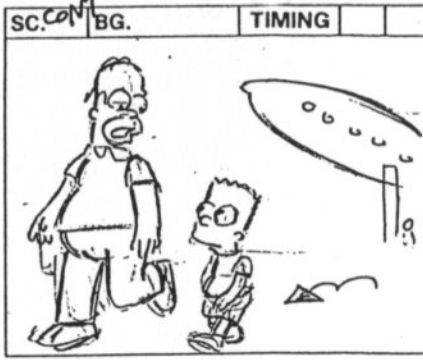
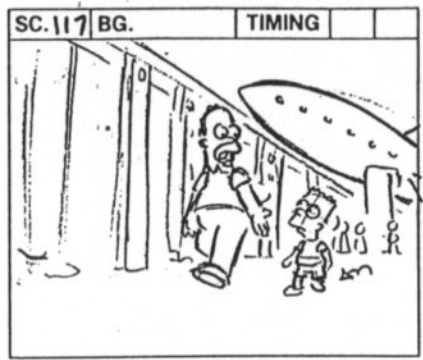
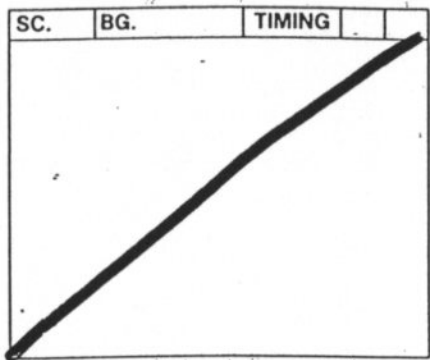

ACTION

TRANS.

DIAL

TRANS.

NOTES

HOMER (CONT'D)
Well, son. I guess this is the end.

TITLE _____

 SHOW BABFO1 ACT 1

E 63

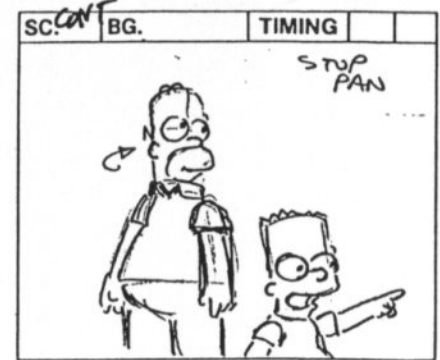
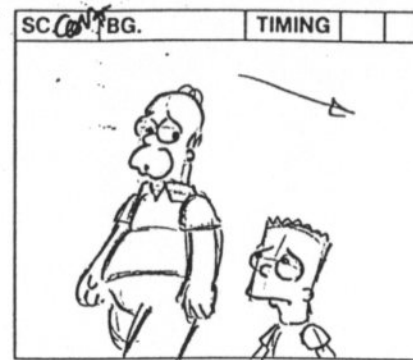
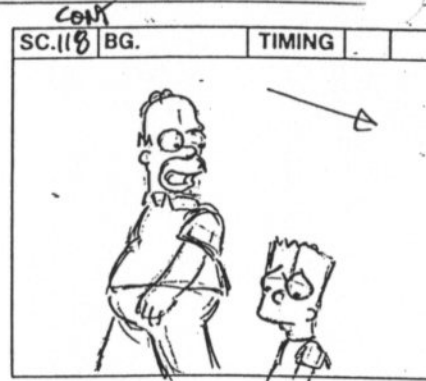

ACTION

TRANS.

DIAL

TRANS.

NOTES

But we've had long,

full lives.

(OFF BART'S PAINED FACE, REALIZING)
Oh, right.

BART
(SPOTTING SOMETHING) Hey, look,
another spaceship!

GRAY

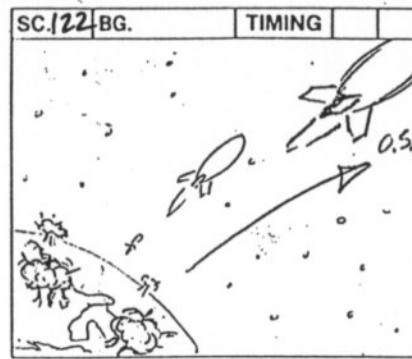
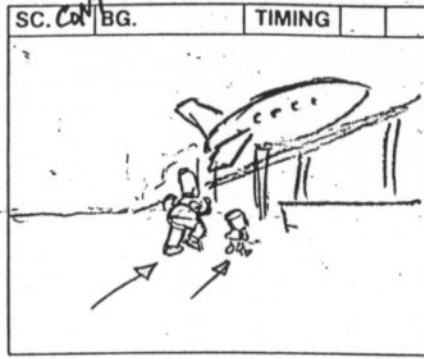
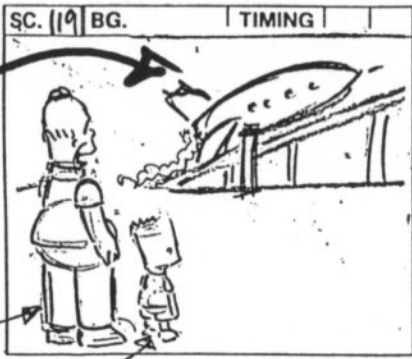

ACTION



They run onto the IDLING spaceship.

TRANS.

DIAL

HOMER

And there's nobody guarding it. Let's go!

TRANS.

NOTES

TITLE _____

SHOW BABFO1 ACT 1

65

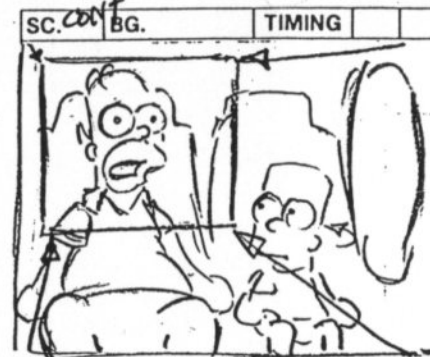
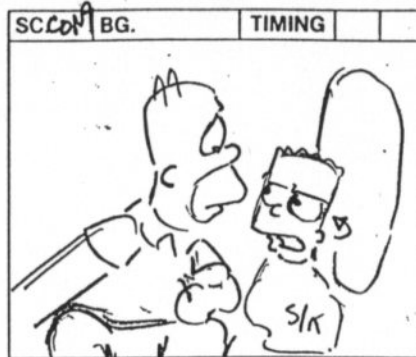
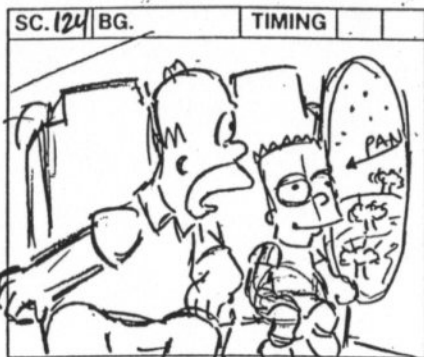
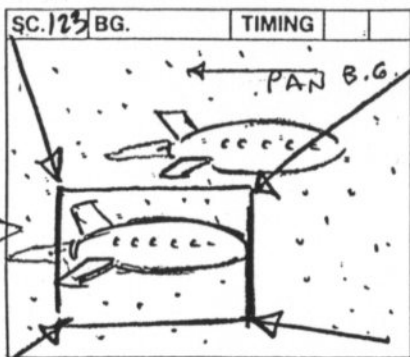

ACTION

GRAY SHIP CATCHES UP TO RED, WHITE & BLUE SHIP.

INT. SPACESHIP - A FEW MILES ABOVE EARTH

- MOMENTS LATER

TRANS.

Homer and Bart are strapped into their seats. Through a porthole window they see a series of ATOMIC EXPLOSIONS on Earth.

DIAL

HOMER

I can't believe I destroyed the Earth.

BART

Are you still talking about the Earth?

HOMER

You're right. I gotta let it go.

TRANS.

NOTES

44 THE SIMPSONS

EPISODE #	BABF01
-----------	--------

EPISODE TITLE	"DESPERATELY XEEKING XENA"
---------------	----------------------------

ACT II

ROUGH DRAFT	4-9-99
-------------	--------

REVISED	4/30/99
---------	---------

FINAL	6/4/99
-------	--------

FILM ROMAN

THE SIMPSONS

TITLE _____

SHOW BASEFO1

ACT II

PAGE 77

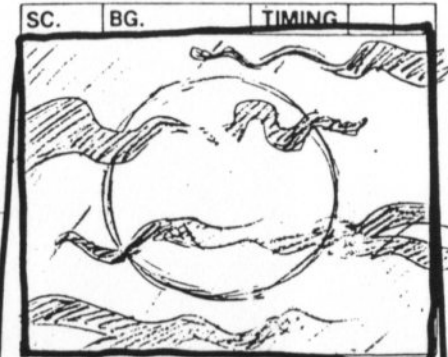
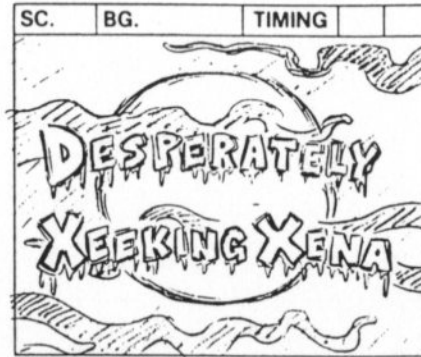
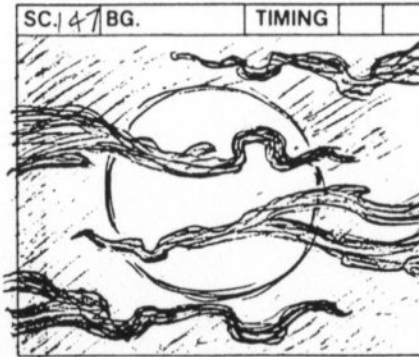

ACTION STORYBOARD BY BRAD ABLESON

◀ MULTIPLANE in clouds

◦ FADE IN superimposed TITLE then FADE OUT

TRANS. DESPERATELY XEEKING XENA
by
Tim Long

FADE IN:

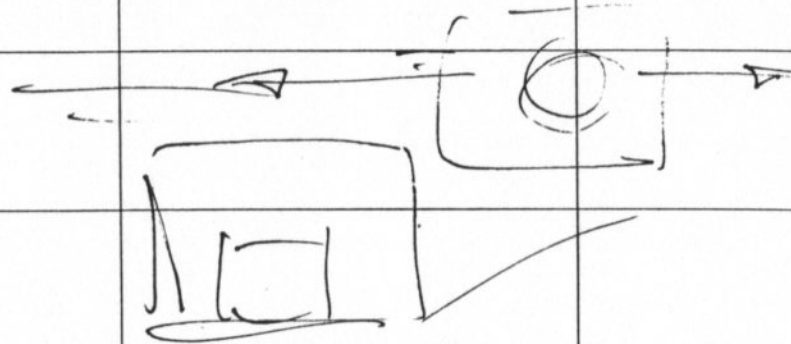

PAN DOWN TO SCHOOL

NOTES EXT. SPRINGFIELD ELEMENTARY - HALLOWEEN NIGHT

A banner reads "Halloween Candy Inspection." Kids in costumes holding bags of candy stream into the school.

FILM ROMAN

THE SIMPSONS

TITLE _____

SHOW BABFOI

ACT II

PAGE 79

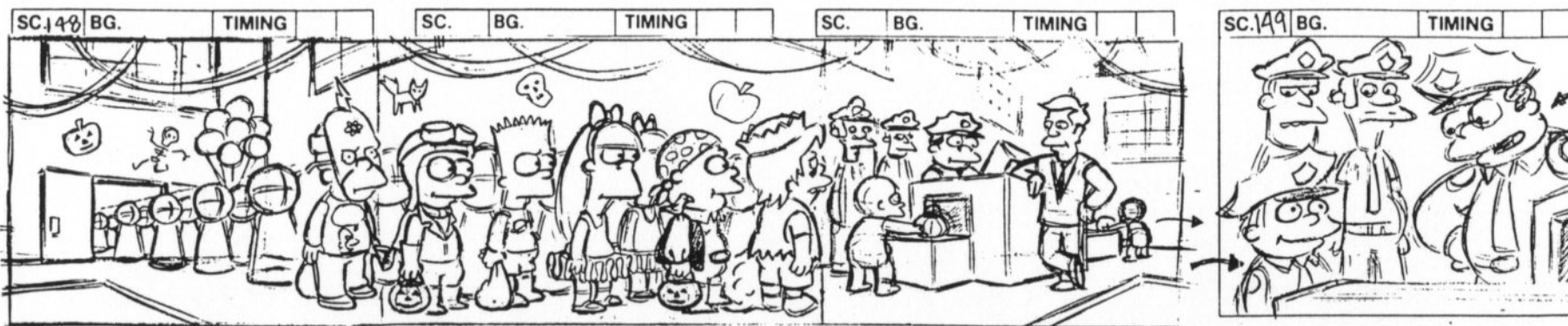

ACTION	<p>START →</p> <p>[PAN]</p> <p>→ STOP</p>	<p>→</p> <p>One kid puts candy into machine while another kid takes his out the other end and puts it in frame.</p>	<p>● Ralph steps into frame</p> <p>● Wiggum leans into frame</p>
TRANS.	<p>INT. SCHOOL GYMNASIUM - CONTINUOUS</p> <p>The CHILDREN stand in line in their Halloween costumes. BART is wearing a red superhero costume (with a planet Saturn logo), while LISA wears a '30s aviator outfit. CHIEF WIGGUM operates an X-ray machine as PRINCIPAL SKINNER looks on.</p>		<p>RALPH WIGGUM, dressed as a policeman, approaches the machine with his bag of candy.</p>
DIAL			<p>CHIEF WIGGUM</p> <p>Well, well, well, if it isn't the cutest police officer in Springfield.</p>
TRANS.			
NOTES			

FILM ROMAN

THE SIMPSONS

TITLE _____

SHOW BABF01 ACT II PAGE 79

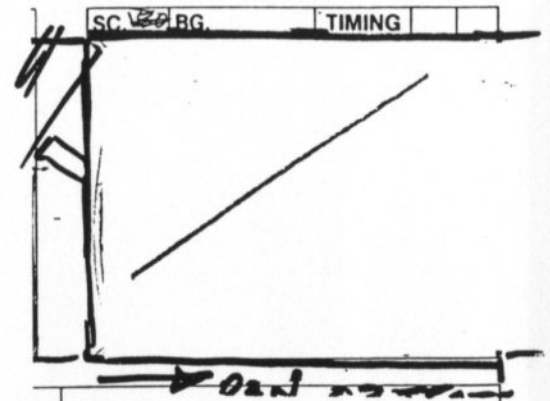
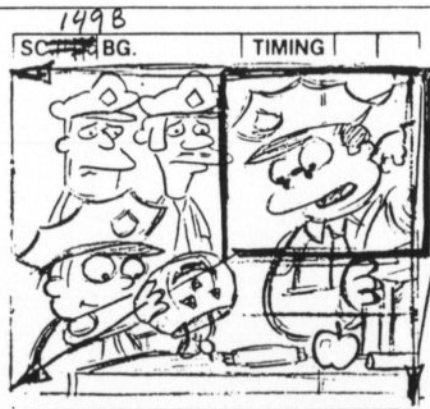

ACTION		<p>_____</p> <p><u>PULLOUT FROM WIGGUM</u> Ralph puts his candy on the conveyor belt and it goes into the machine.</p>	
TRANS.			
DIAL	<p>LOU</p> <p>Hey, you know, we got feelin's too, Chief.</p>	<p>CHIEF WIGGUM</p> <p>Just dump your candy on the X-ray belt, Ralphie. There's a good boy.</p>	
TRANS.			
NOTES			

FILM ROMAN

THE SIMPSONS

TITLE _____

SHOW BABFO1

ACT II

PAGE 79A

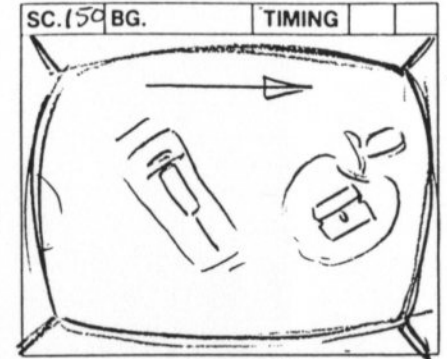
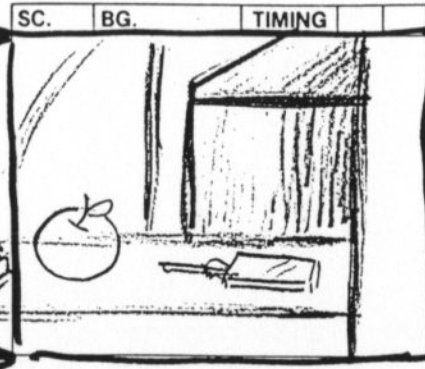
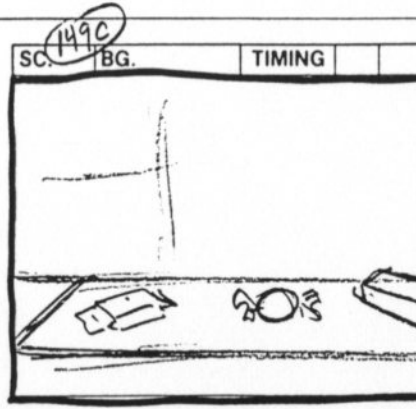
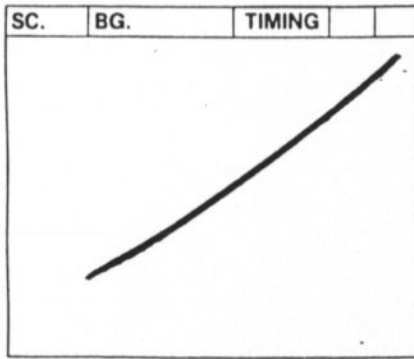

ACTION

PAN W/CANDY

X-RAY

We see the candy pass by the X-ray monitor (It never stops moving.) Some of the candy clearly contains dangerous objects. (We should only see the items that Wiggum refers to.)

TRANS.

DIAL

TRANS.

NOTES

FILM ROMAN

THE SIMPSONS

150A

TITLE _____

SHOW BABFOI

ACT II

PAGE 37

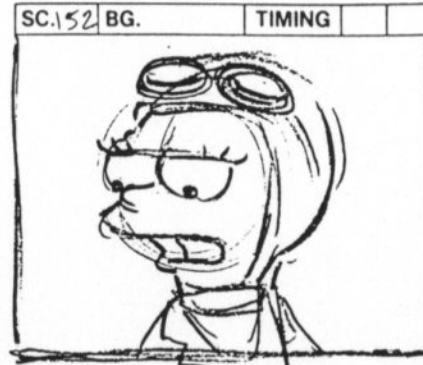
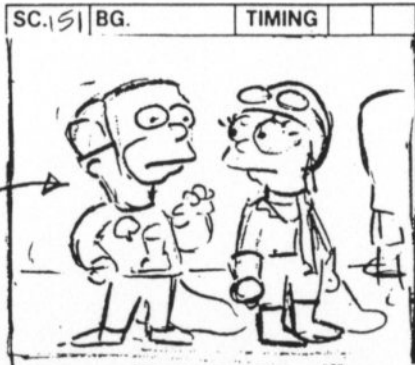

ACTION



MILHOUSE
I DON'T THINK THE REAL
RADIOACTIVE MAN
WEARS A MASK

LOOKS HIMSELF OVER.

TRANS.

ANGLE ON
Milhouse talking to Lisa in line.

Milhouse looks down at his
cheap store-bought costume,
which has a picture of
Radioactive Man on it saying "Trick
or Treat!"

DIAL

CHIEF WIGGUM
(LOOKING AT MONITOR, MATTER OF FACT)
Good... good... razor blade...
syringe... och, white chocolate!

MILHOUSE
Check it out, Lisa. I'm Radioactive
Man.

LISA
I don't think the real Radioactive Man
wears a plastic smock with a picture of
himself on it.

TRANS.

NOTES

FILM ROMAN

THE SIMPSONS

TITLE _____

SHOW BABFOI

ACT II

PAGE 51

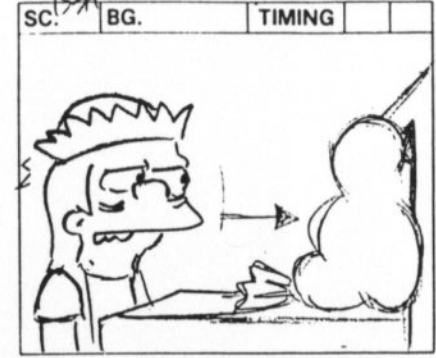
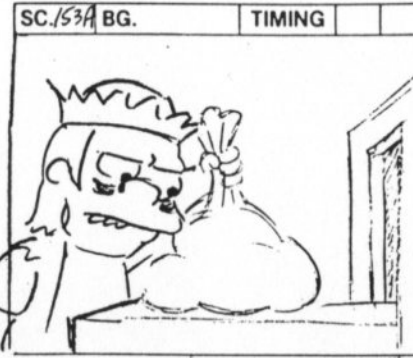
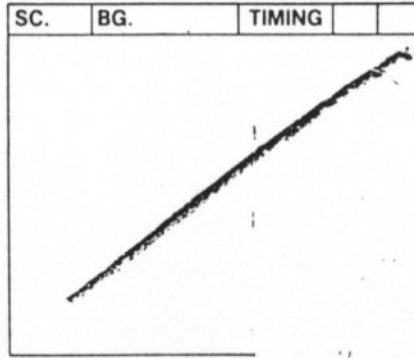
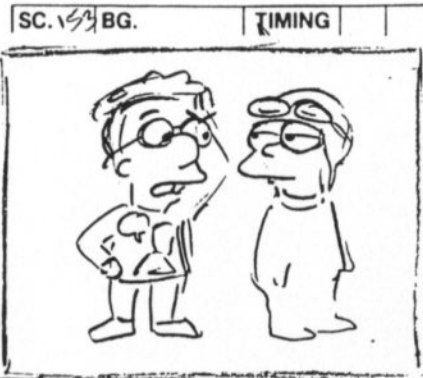

ACTII

*© CANDY machine (filled
a pillowcase)*

Nelson, wearing a "Little Rascals" bully crown-type hat and some black make-up smeared under his eyes, is shoving an over-stuffed pillowcase full of candy into the X-ray machine.

TRANS.

DIAL

MILHOUSE
(DEFENSIVE) He would on Halloween.

TRANS.

NOTES

FILM ROMAN

THE SIMPSONS

SHOW BABFO1 ACT II PAGE 82



ACTION		<p>WIGGUM LEANS IN TRUCK. OUT WIDER</p>	<p>The machine SHAKES and makes a GEAR-JAMMING SOUND.</p>	<p>EVERYONE BACKS AWAY AS MACHINE GRATES</p>
TRANS.				<p>Smoke starts to pour out.</p>
DIAL	<p>NELSON (PUNCHING BAG, IMPATIENT) Get in there, you stupid pillowcase.</p>	<p>CHIEF WIGGUM Stop it! You'll jam the machine!</p>		
TRANS.				
NOTES				

FILM ROMAN

THE SIMPSONS

TITLE _____

SHOW BABFDI

ACT 2

PAGE 83

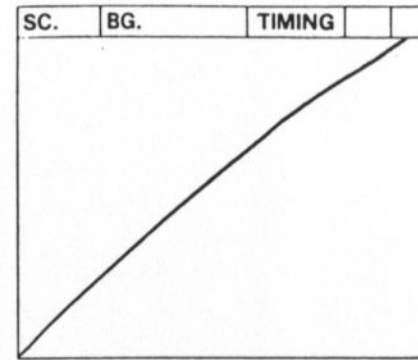
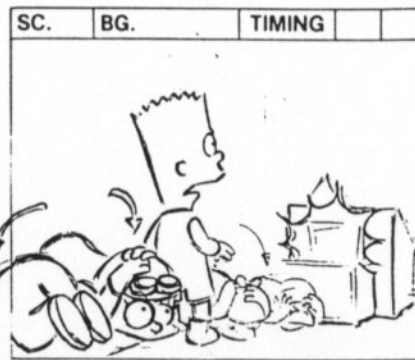
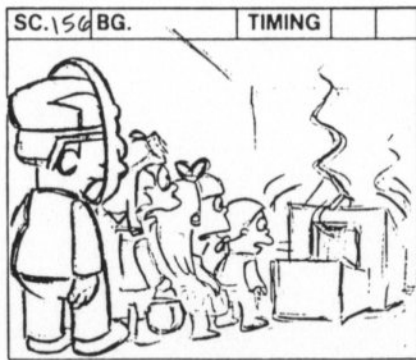
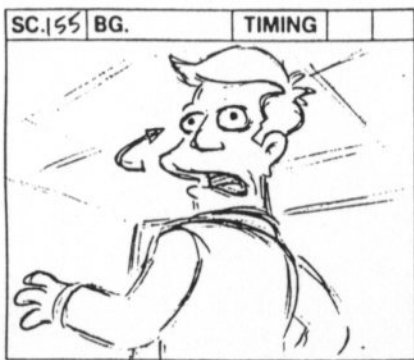

ACTION	<p>SKINNER WHIPS HEAD AROUND</p>		<p>All the kids except for Bart hit the deck. Bart stares dumbly at the RUMBLING X-ray machine.</p>	
TRANS.				
DIAL	<p>PRINCIPAL SKINNER Radiation! Duck and cover!</p>			
TRANS.				
NOTES				

FILM ROMAN

THE SIMPSONS

TITLE _____ SHOW BABFO ACT 2 PAGE 83A

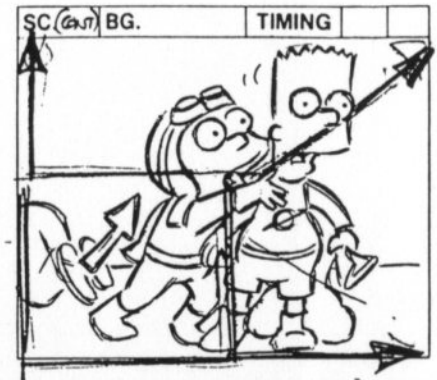
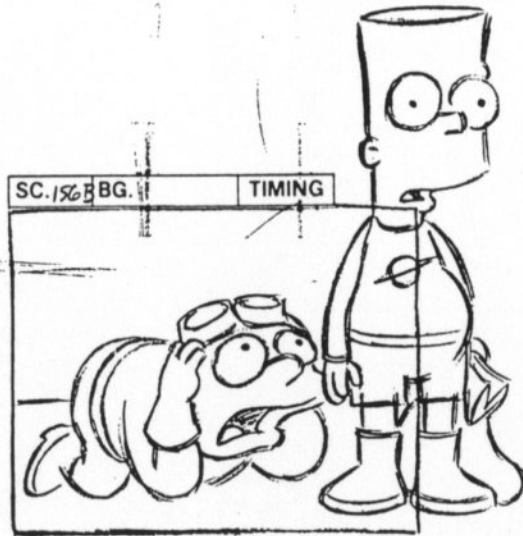
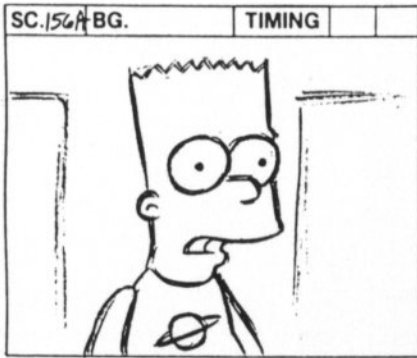

ACTION	DX GREEN GLOW ON BART'S FACE.		WIDEN She jumps up and grabs Bart.
TRANS.		Lisa looks up from the floor and sees Bart.	
DIAL	BART Cool...	LISA Bart!	
TRANS.			
NOTES			

FILM ROMAN

THE SIMPSONS

TITLE _____

SHOW BABF01

ACT _____

PAGE 23B

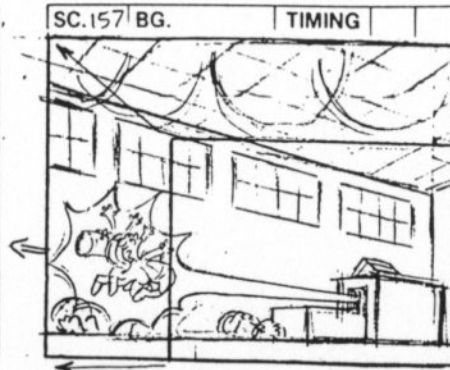
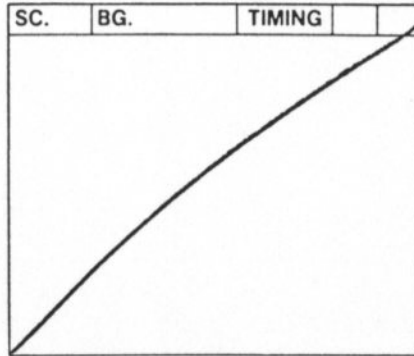
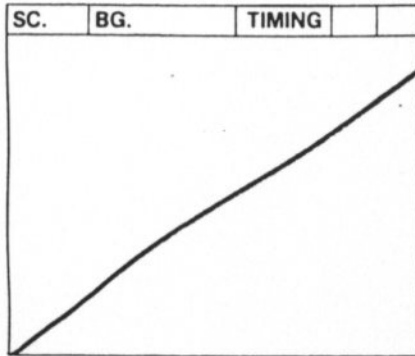

ACTION

WIDEN AS BART & LISA ARE HIT

TRANS.

The machine BLASTS a column of green light at Bart and Lisa.

DIAL

START BART & LISA STANDING IN FIELD

TRANS.

NOTES

AGAINST DOOR



FILM ROMAN

THE SIMPSONS

TITLE _____

SHOW BABFOI

ACT II

PAGE 84

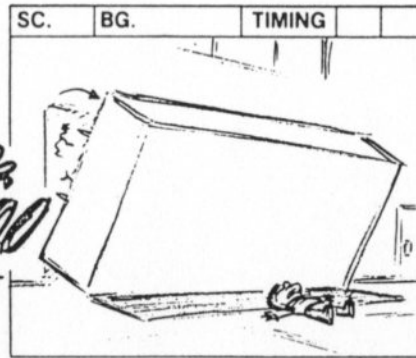
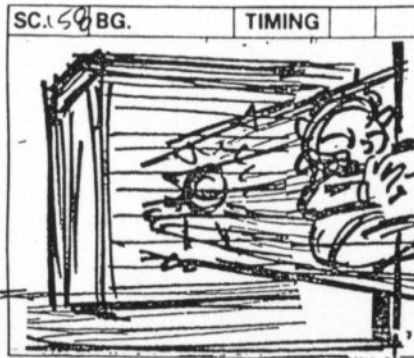

ACTION

⓪ LISA FLIES INTO FRAME, HITS BLEACHERS & LANDS UNDER.

⓪ BLEACHERS START TO TIP

The shock sends them FLYING off-screen.

TRANS.

DIAL

TRANS.

NOTES

⓪ ADJUST UP/TWIST IN

PRINCIPAL SKINNER (CONT'D)
(LOOKING OFF-SCREEN) Oh, my God!
Lisa!

FILM ROMAN

THE SIMPSONS

TITLE _____

SHOW BABFOI

ACT II

PAGE 25

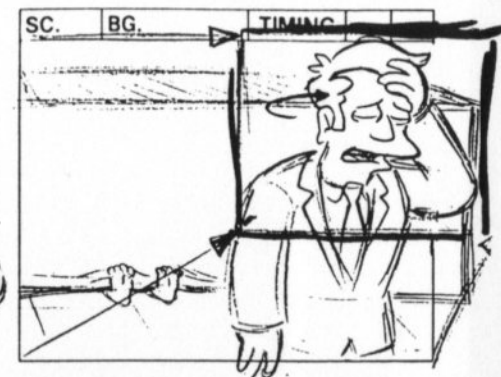
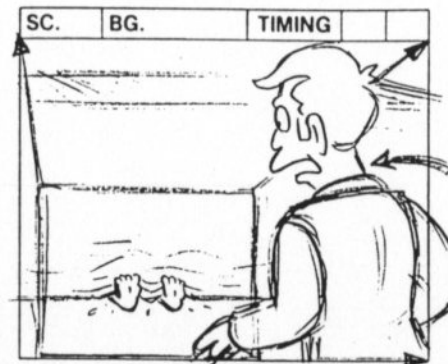
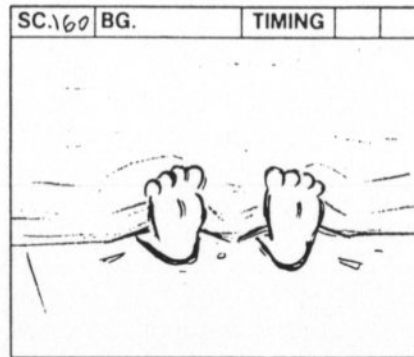

ACTION	A panicky Skinner runs over to the bleachers, which have collapsed on top of Lisa. Her feet stick out from under the bleachers, a la the witch under the house in "The Wizard of Oz."	⊙ QUICK PULL OUT AS SKINNER RUSHES INTO FRAME	⊙ TRUCK IN ON SKINNER
TRANS.			
DIAL		PRINCIPAL SKINNER (CONT'D) She's been crushed!	(SOLEMN) And so have the hopes of our mathletics team.
TRANS.			
NOTES			

FILM ROMAN

THE SIMPSONS

CNT

TITLE _____

SHOW BARTFOI

ACT II

PAGE 86

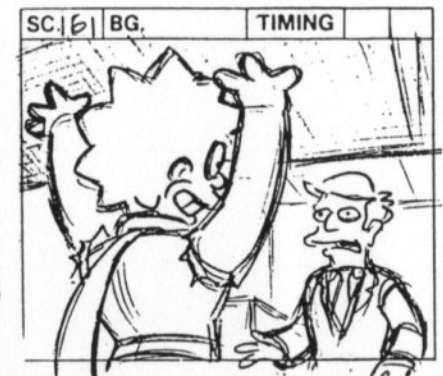
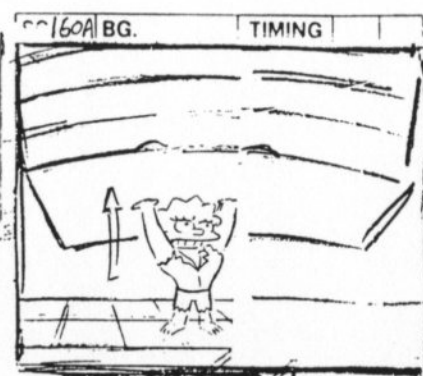
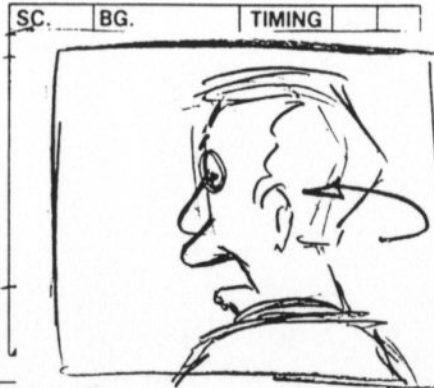

ACTION

BLEACHER BEGINS TO RISE
BEHIND SKINNER

TRANS.

Suddenly, the bleachers STIR and rise into the air. We see Lisa is lifting them from below, like Superman hoisting a car. (Lisa's aviator outfit is torn at the sleeves like The Hulk.)

DIAL

LISA (O.S.)
Hold the funeral, Poindexter.

PRINCIPAL SKINNER

(GASP) Poindexter?!

TRANS.

NOTES

FILM ROMAN

THE SIMPSONS

TITLE _____

SHOW BABF01

ACT II

PAGE 87

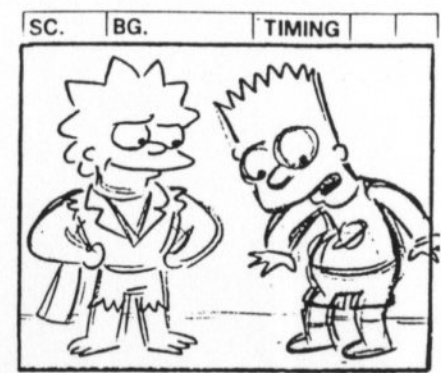
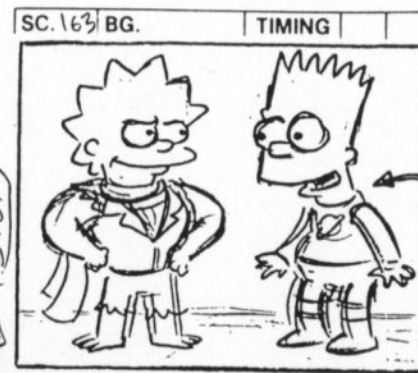
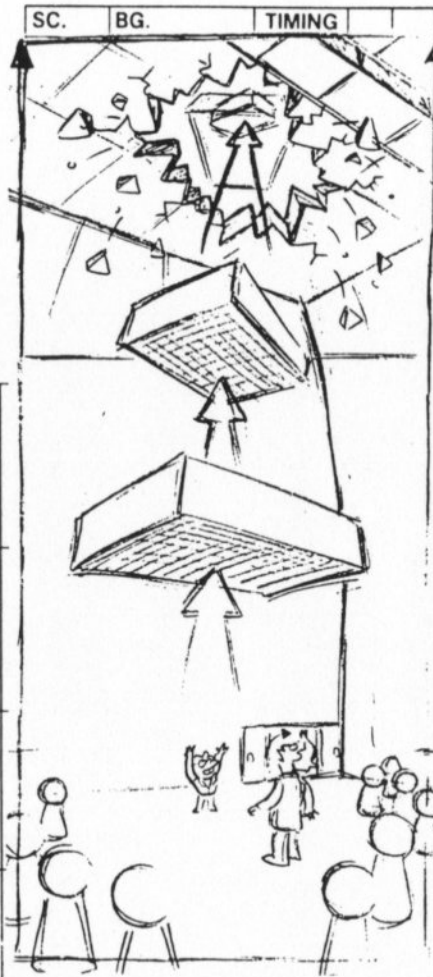
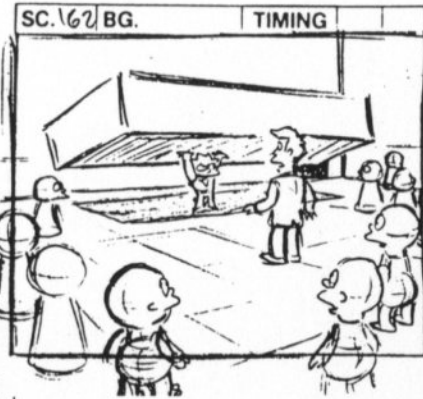

ACTION

TRANS.

DIAL

TRANS.

NOTES

(STOP)

(PAN)

(START)

⊙ BART RUNS INTO FRAME

ANGLE ON BART

BART

Whoa, Lis, those X-rays must've given you super strength.

I wonder if I got any powers...

She HURLS the bleachers THROUGH the roof of the gym and into space.

FILM ROMAN

THE SIMPSONS

TITLE _____ SHOW BABFOI ACT II PAGE 88

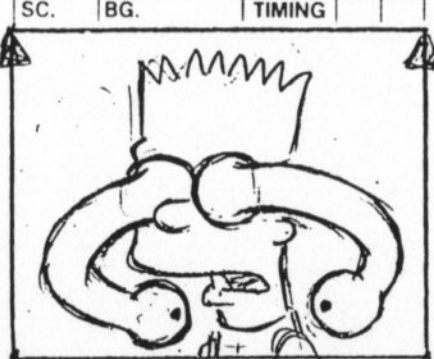
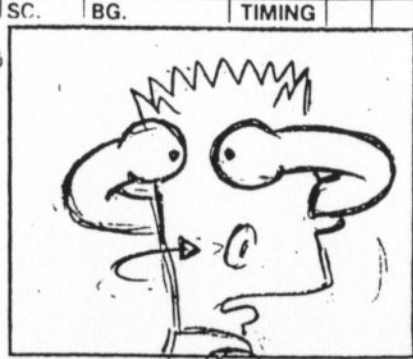
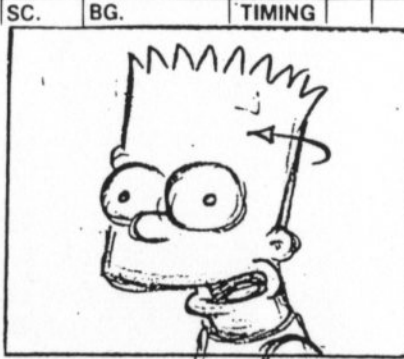
	SC. 164	BG.	TIMING	SC.	BG.	TIMING	SC.	BG.	TIMING	SC.	BG.	TIMING
ACTION												
TRANS.							<p>Ⓞ BART TURNS AWAY</p> <p>His eyes, which are now behind his back, stare at each other in realization, then SNAP back.</p>			<p>Ⓞ BART TURNS BACK</p>		
DIAL	<p>Ⓞ ADJUST DOWN WITH EYEBALLS</p> <p>Bart's eyes STRETCH out of their sockets (not on stalks) and look all over his body.</p>			<p>Ⓞ ADJUST UP WITH EYEBALLS</p>						<p>BART (CONT'D)</p> <p>I can stretch!</p>		
TRANS.				<p>BART (CONT'D)</p> <p>No, looks normal...</p>								
NOTES												

FILM ROMAN

THE SIMPSONS

SHOW BABFO1 ACT II PAGE 89

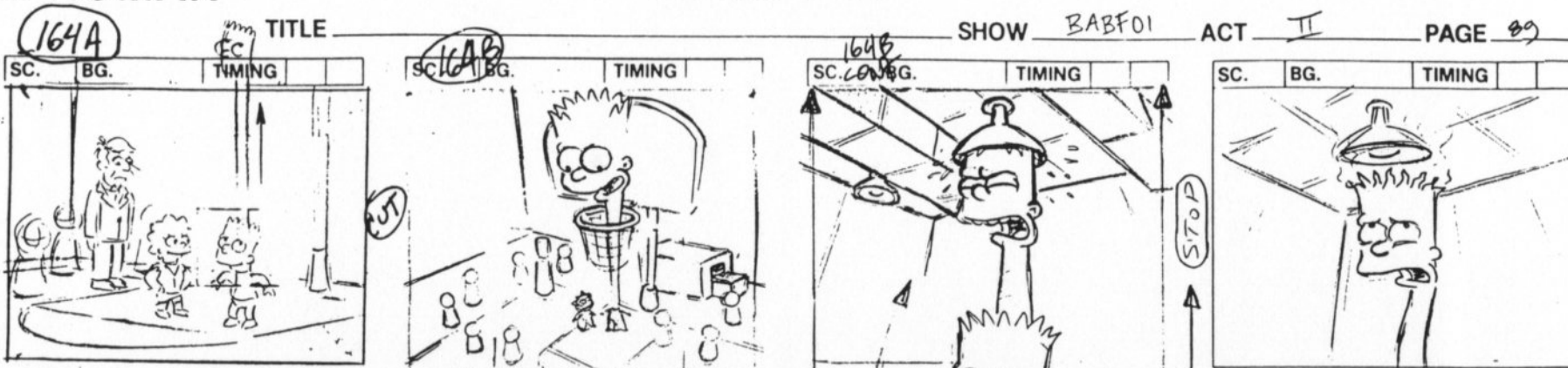

	SC.	BG.	TIMING	TITLE	SC.	BG.	TIMING		SC.	BG.	TIMING	
ACTION				BARTS HEAD STRETCHES U.P.								
TRANS.				Bart ELONGATES his neck, extending his head up through the basketball hoop.								It SIZZLES on Bart's hair.
DIAL				 START POSE								
TRANS.				BART (CONT'D) Look at me!								(QUICKLY) Hot-hot-hot!
NOTES												

His head quickly CONTINUES UP and HITS a hanging light.

BART (CONT'D)

Ow!

FILM ROMAN

THE SIMPSONS

TITLE _____

SHOW BABFOI

ACT II

PAGE 40

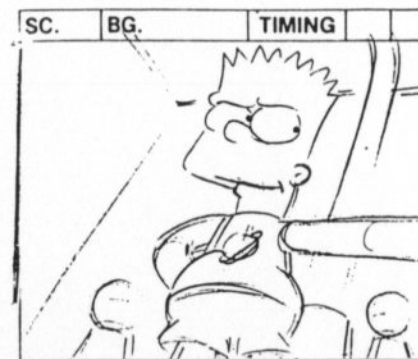
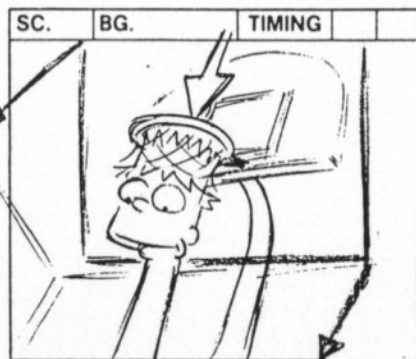
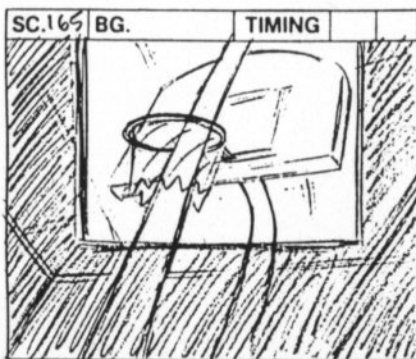

ACTION

⊙ WIDEN AS BART'S
HEAD COMES THRU

⊙ BART REACHES U.S.

TRANS.

His head quickly **RETRACTS** through the hoop and into normal position.

DIAL

BART (CONT'D)
(DRAMATICALLY) I must only use this
power to annoy.

TRANS.

NOTES

FILM ROMAN

THE SIMPSONS

TITLE _____ SHOW BABFO1 ACT II PAGE 91



ACTION	SC. 166	SC. 167	SC. 167
	← [ADJUST] ←		→ [ADJUST] →
	⊙ AFTER HAND GOES OUT WINDOW, ADJUST LEFT	A beat later we hear a KNOCK at an adjoining door.	⊙ SKINNER TAKES ONE STEP & OPENS DOOR
TRANS.	Bart shoots his arm out an open window.		He OPENS the door. We see Bart's outstretched hand there.
DIAL		PRINCIPAL SKINNER Now, who could that be at this hour?	
TRANS.			
NOTES			

FILM ROMAN

THE SIMPSONS

TITLE _____

SHOW BABFO

ACT II

PAGE 92

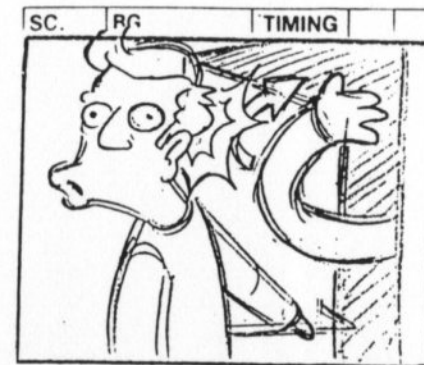
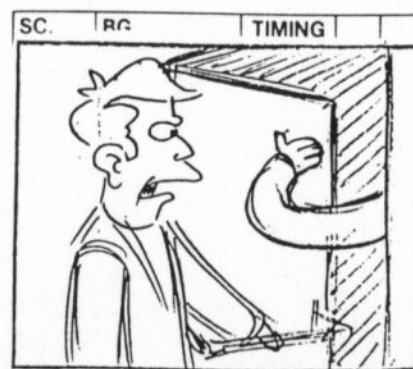
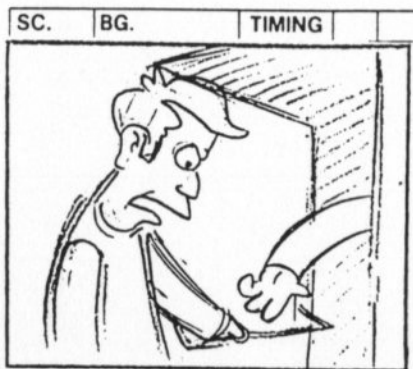

ACTION

His hand flutters around a la the Three Stooges.

The hand SLAPS him.

TRANS.

DIAL

PRINCIPAL SKINNER (CONT'D)
Yes, yes... Up,

down... Side-to- side...

What's your point?

PRINCIPAL SKINNER
Ow!

TRANS.

NOTES

FILM ROMAN

THE SIMPSONS

TITLE _____

SHOW BABFOI

ACT II

PAGE 93

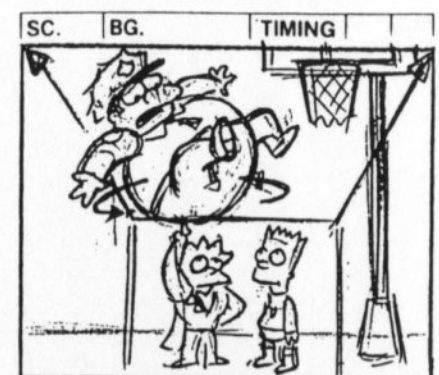
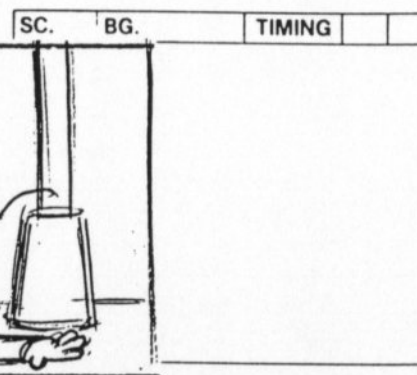
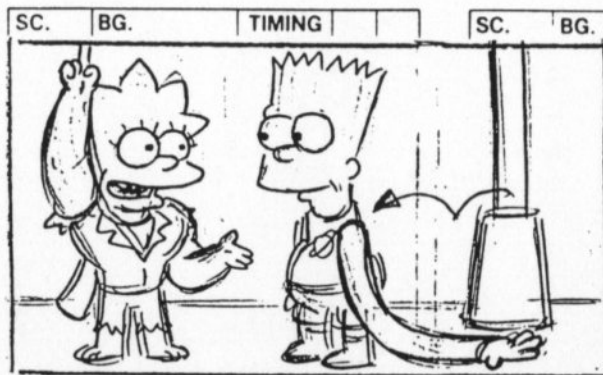
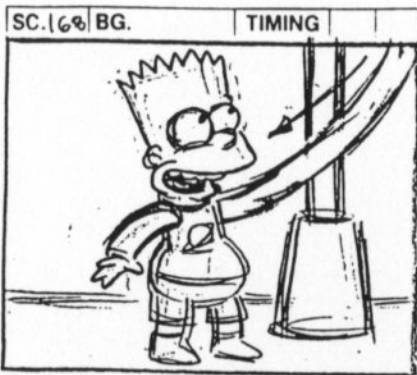

ACTION

Ⓢ HAND COMES BACK INTO FRAME

← ADJUST →

Ⓢ ADJUST LEFT W/ BART, WHILE HE REELS ARM BACK IN.

Ⓢ QUICK TRUCK OUT
6F → 12F

TRANS.



ANGLE ON LISA
Bart walks up reeling his arm back in.

WIDEN to reveal Lisa spinning Chief Wiggum on her finger like a basketball.

DIAL

BART
(CHUCKLING) Gotcha.

LISA
Bart, with these powers, we can become superheroes!

CHIEF WIGGUM
(SCARED) Okay, so do it already!

TRANS.

NOTES

FILM ROMAN

THE SIMPSONS

TITLE _____

SHOW BABFO1

ACT II

PAGE 94

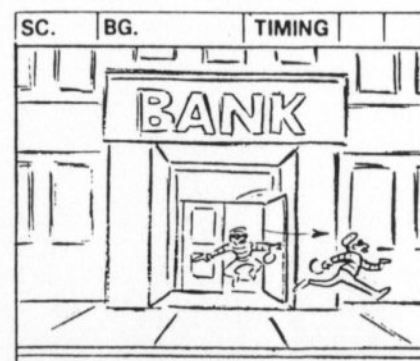
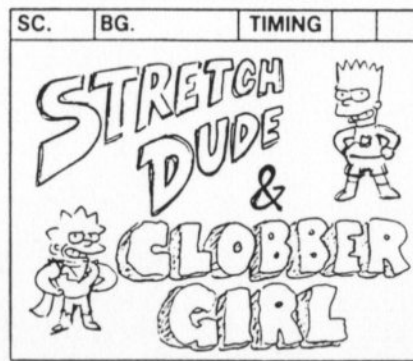
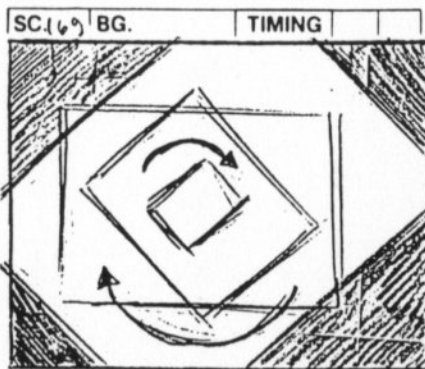

ACTION

An art card SPINS into frame, which reads "Stretch Dude and Clobber Girl." Bart and Lisa stand proudly beside their names in block letters.

DOOR FLIES OPEN...

TRANS.

MUSICAL TITLE SEQUENCE

DIAL

SINGERS

STRETCH DUDE AND CLOBBER GIRL /

HE'S A HUMAN RUBBER BAND

AND SHE'S THE HULK IN PEARLS!

TRANS.

NOTES

FILM ROMAN

THE SIMPSONS

TITLE _____

SHOW BABFOI ACT II

PAGE 95

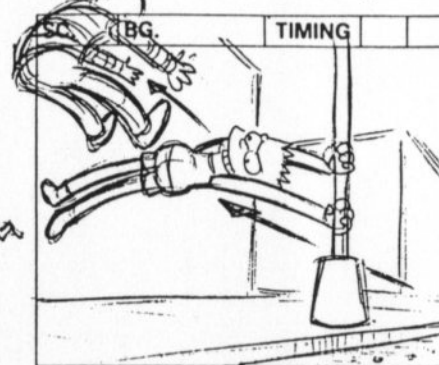
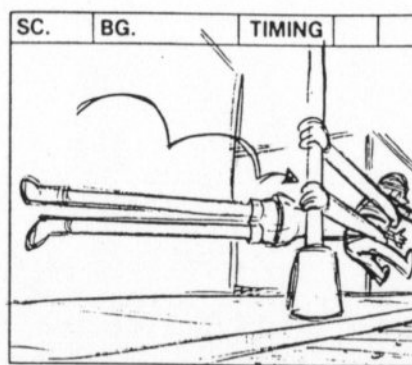
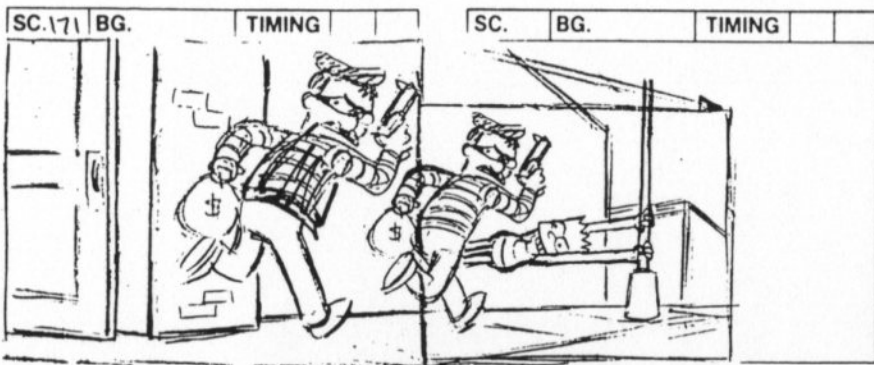

ACTION

→ → **ADJUST** →

⊙ RUBBER BACKS OUT & RUNS DOWN STREET.

He runs into Bart, who has stretched himself into a sheet of rubber between a lamppost and a building.

⊙ RUBBER GETS PROPELLED ⊙

TRANS.

A BANK ROBBER, carrying a bag of money,
SPRINTS down the sidewalk.

DIAL

TRANS.

NOTES

FILM ROMAN

THE SIMPSONS

171A

TITLE _____

SHOW BABFOI

ACT II

PAGE 96

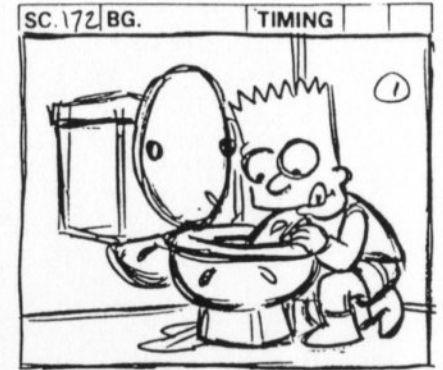
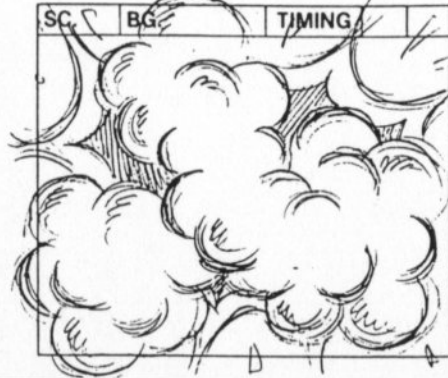
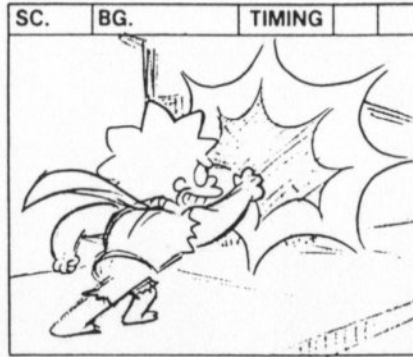
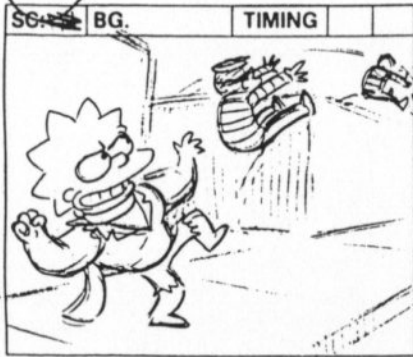

ACTION

● RUBBER ENTERS FRAME

The criminal BOUNCES back into Lisa,

who PUNCHES him in mid-air.

● EXPLOSION FILLS FRAME

The bank robber EXPLODES.

● BARTS HAND SPLASHES AROUND

Bart is reaching his hand down the toilet.

TRANS.

DIAL

TRANS.

NOTES

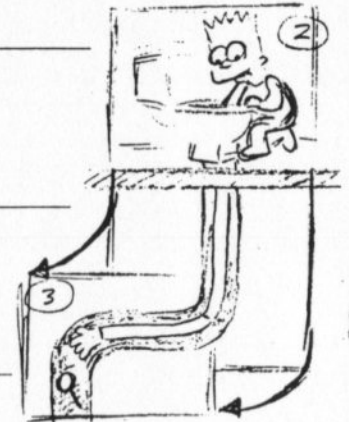

FILM ROMAN

THE SIMPSONS

TITLE _____

SHOW BABFOI ACT II

PAGE 97

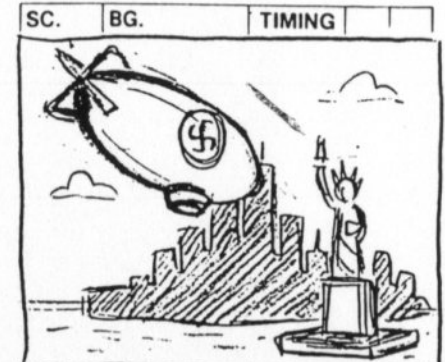
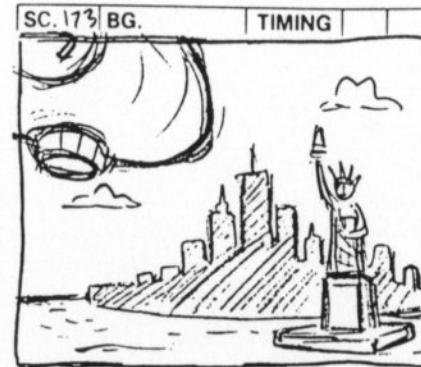
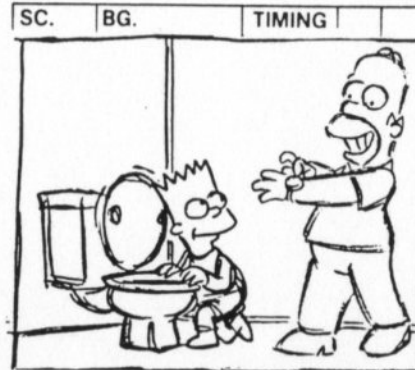
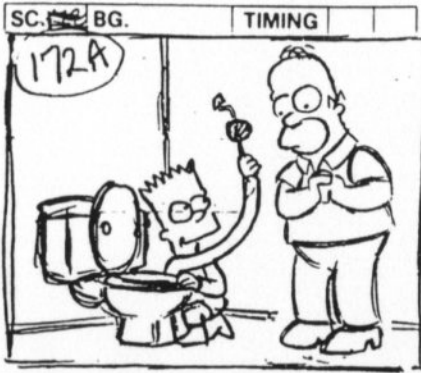

ACTION

ⓐ TRUCK OUT

He pulls out a wrist watch and hands it to Homer,

who slides it on his wrist and reacts gratefully.

ⓐ ZEPPELIN ENTERS FRAME

A Nazi zeppelin approaches New York.

TRANS.

DIAL

SINGERS (CONT'D)
HE'S A LIMBER LAD...

TRANS.

NOTES

FILM ROMAN

THE SIMPSONS

TITLE _____ SHOW BABFD! ACT II PAGE 45

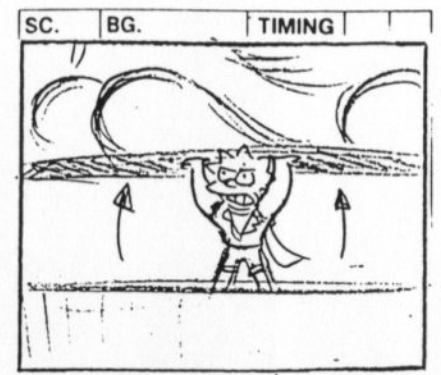
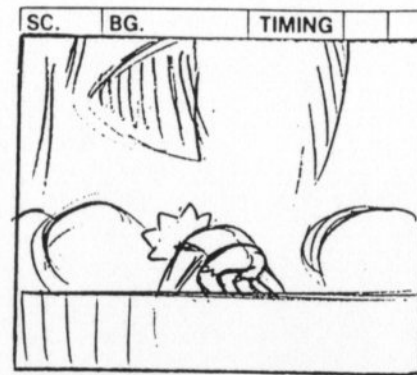
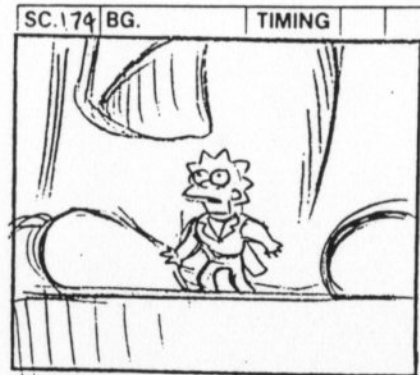

ACTION			
TRANS.			Lisa picks up the Statue of Liberty.
DIAL			
TRANS.			SINGERS (CONT'D) SHE'S A POWERFUL LASS...
NOTES			

FILM ROMAN

THE SIMPSONS

TITLE _____

SHOW BABFDI

ACT II

PAGE 33

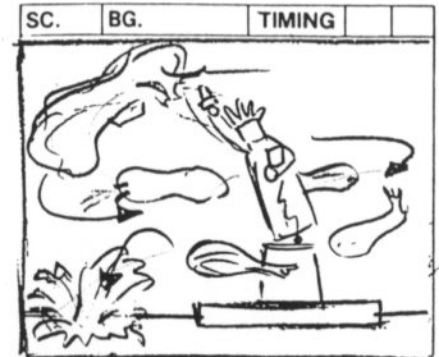
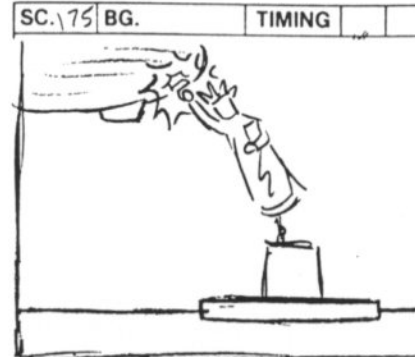
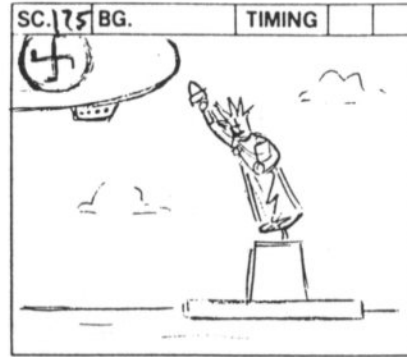

ACTION

AS ZEPPELIN ENTERS
FRAME, LISA ANGES
STATUE TO "POKE"

and uses its torch to poke
a hole in the zeppelin,

which quickly ZIPS AROUND losing air like a
balloon and CRASHES into the Atlantic.

TRANS.

DIAL

TRANS.

NOTES

FILM ROMAN

THE SIMPSONS

175 CONT

TITLE _____

SHOW BABFOI

ACT II

PAGE 100

176
OUT

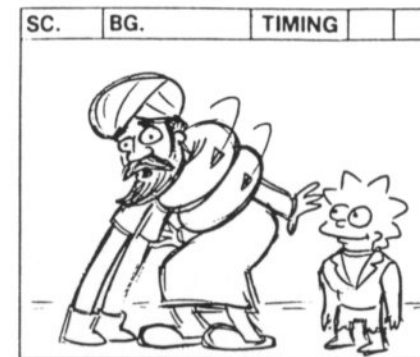
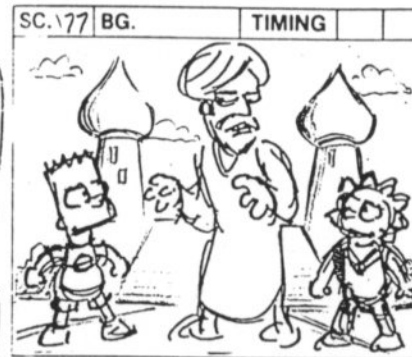

ACTION

TRANS.

DIAL

TRANS.

NOTES

Bart WRAPS himself around the
~~ATROCEMAN'S~~ neck,
SADAM HUSSEIN

SINGERS (CONT'D)
HE'LL WRING YOUR NECK,

FILM ROMAN

THE SIMPSONS

CONT _____ TITLE _____ SHOW BABFOI ACT II PAGE 101

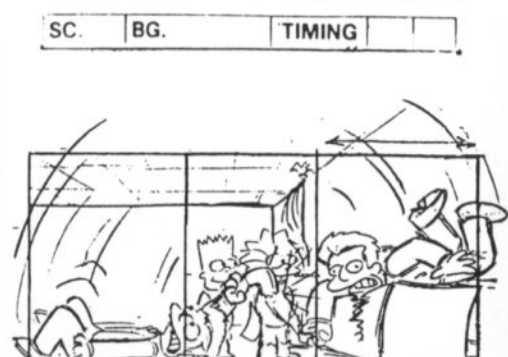
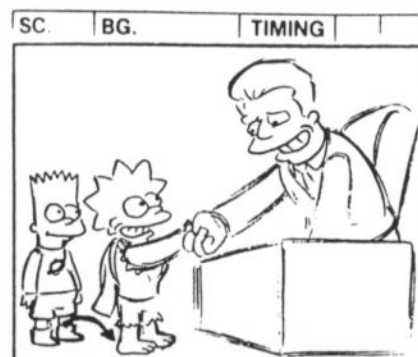
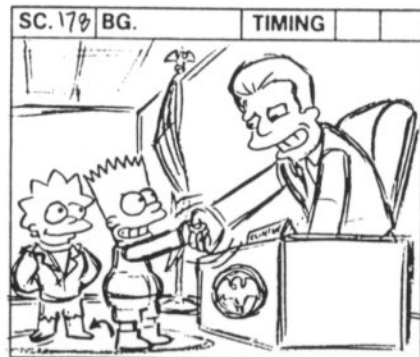
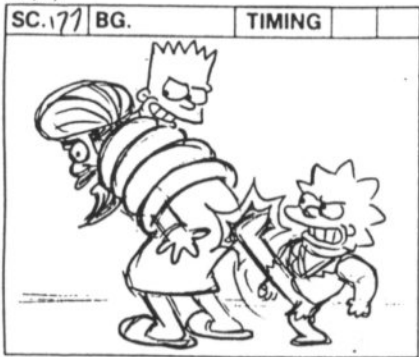

ACTION	while Lisa KICKS him in the ass severely.	<p>Ⓞ BART SHAKES & BACKS AWAY</p> <p>The kids shake hands with PRESIDENT CLINTON.</p>	<p>Ⓞ LISA STEPS FORWARD</p> <p>PAN BACK & FORTH W/ ACTION</p>
TRANS.			When Lisa shakes Clinton's hand, she SMASHES him up and down, Bam-Bam style.
DIAL	AND SHE'LL KICK YOUR ASS!	<p>SINGERS</p> <p>THEY'RE STRETCH DUDE!</p>	AND CLOBBER GIRL!
TRANS.			
NOTES			

FILM ROMAN

THE SIMPSONS

TITLE _____

SHOW BABFOL

ACT II

PAGE 102

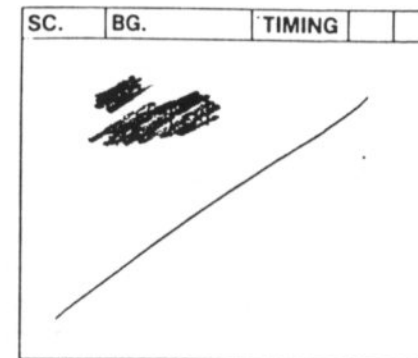
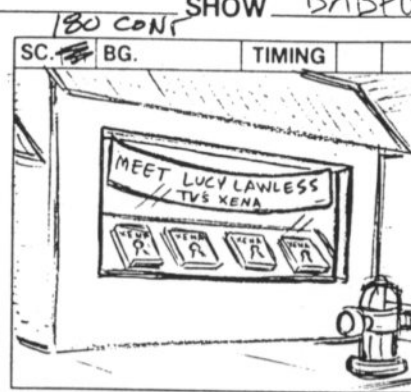
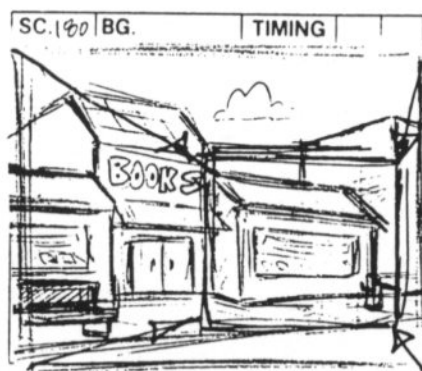

ACTION

CUT TO an art-card reading, "TONIGHT'S EPISODE: ENTER THE COLLECTOR." There is a picture of COMIC BOOK GUY dressed as a super-villain called the Collector. He is peering down through a jeweler's loupe at a tiny Stretch Dude and Clobber Girl.

EXT. BOOKSTORE - AFTERNOON

A sign in the bookstore window reads, "Meet Lucy Lawless -- TV's Xena."

TRANS.

DIAL

ANNOUNCER (V.O.)

Tonight's episode: "Enter the Collector."

TRANS.

NOTES

FILM ROMAN

THE SIMPSONS

TITLE _____

SHOW BABFOI

ACT 2

PAGE 102A

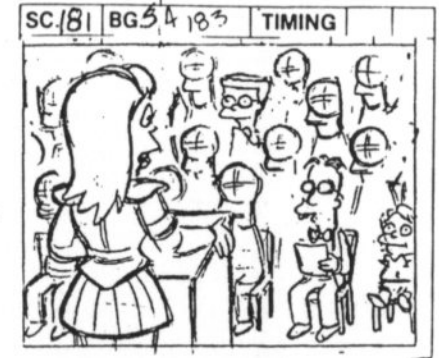
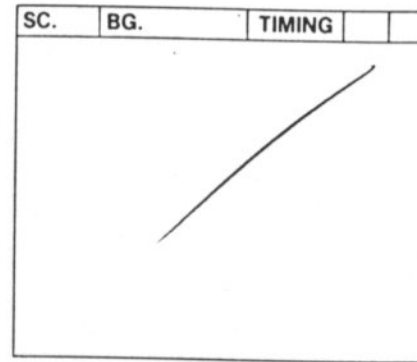
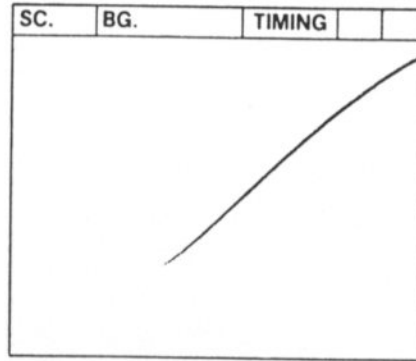
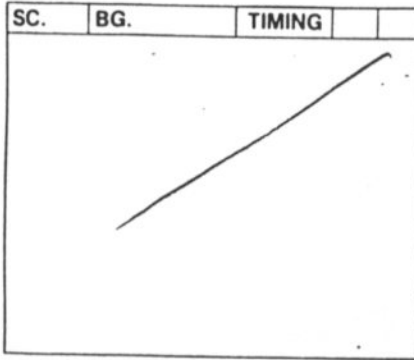

ACTION

TRANS.

DIAL

TRANS.

NOTES

			<p>LUCY LAWLESS</p> <p>... But I'm sure that once girls get to know the real you,</p>

FILM ROMAN

THE SIMPSONS

TITLE _____

SHOW BABFDI ACT 2

PAGE 102B

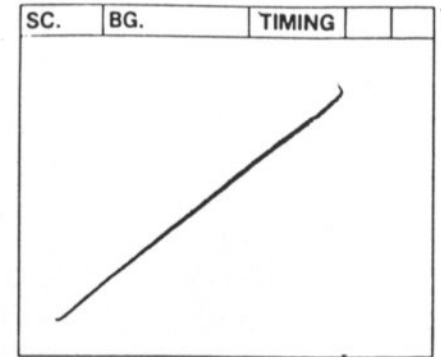
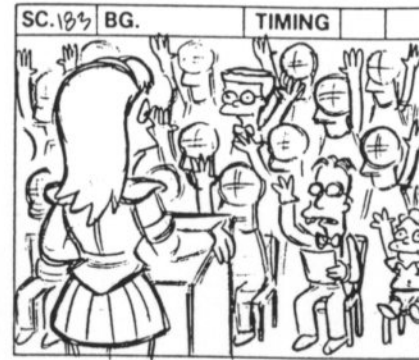
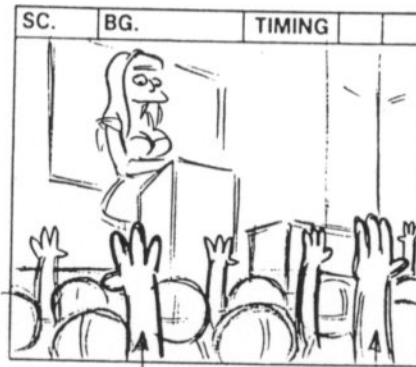
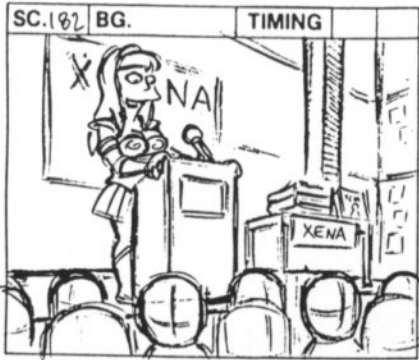

ACTION

INT. BOOKSTORE - CONTINUOUS

LUCY LAWLESS, in full Xena costume, stands at a lectern. Several townspeople sit before her, including FRINK, MARTIN PRINCE, SMITHERS and DOUG and GARY (the college nerds).

① LOTS OF HANDS UP

② HANDS GO BACK DOWN

TRANS.

DIAL

you'll get plenty of dates. Next question.

PROF. FRINK
Yes, over here. (FRINK NOISE) In episode BF12 you were battling barbarians while riding a wing-ed Appaloosa.

TRANS.

NOTES

FILM ROMAN

THE SIMPSONS

SHOW BABFO1 ACT II PAGE 23

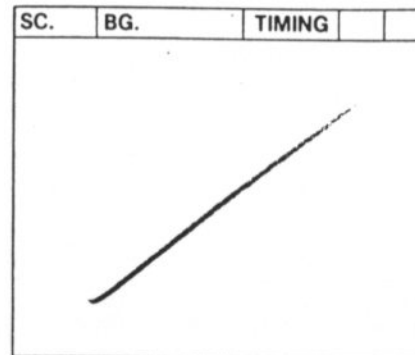
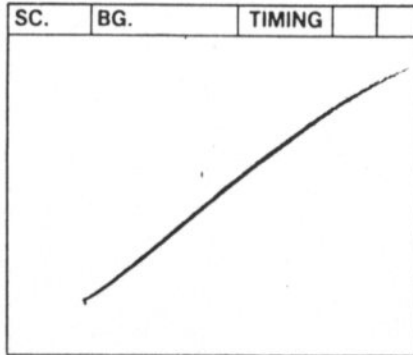

ACTION			
TRANS.			
DIAL	<p>FRINK CONT (0.5)</p> <p>Yet in the very next scene, my dear,</p>		<p>you're clearly atop a wing-ed Arabian. Please to explain it.</p>
TRANS.			
NOTES			

FILM ROMAN

THE SIMPSONS

TITLE _____ SHOW BABFO1 ACT II PAGE 109



ACTION			Ⓢ XENA LEANS FORWARD	(DISAPPOINTED)
TRANS.				
DIAL	LUCY LAWLESS	PROP. FRINK	LUCY LAWLESS	PROP. FRINK
TRANS.	Uhh, whenever you notice something like that, a wizard did it.	I see, all right, yes. But in episode AG4...	(QUICKLY) Wizard.	Oh, for glayvin out loud.
NOTES				

FILM ROMAN

THE SIMPSONS

SHOW BABFOI

ACT II

PAGE 105

SC.	BG.	TIMING
-----	-----	--------

SC. (09)	BG.	TIMING
----------	-----	--------

SC.	BG.	TIMING
-----	-----	--------



● GLASS ENTERS FRAME
AS HEADS TURN TO
LOOK

Suddenly, the glass roof SHATTERS.

ACTION

TRANS.

DIAL

TRANS.

NOTES

FILM ROMAN

THE SIMPSONS

TITLE _____

SHOW BABFOI

ACT II

PAGE 106

	SC. 90	BG.	TIMING	SC	BG.	TIMING	SC. 90A	BG.	TIMING	SC. 101	BG.	TIMING
ACTION												
TRANS.	<p>START</p> <p>PAW</p> <p>STOP</p>			<p>COMIC BOOK GUY, dressed as a super-villain, is lowered down, standing atop a large electro-magnet (as used in auto junkyards).</p>						<p>Ⓢ BUTTON IS LIFTED INTO FRAME; THEN PRESSED.</p>		
DIAL										<p>He pushes a hand-held button</p>		
TRANS.				<p>COMIC BOOK GUY</p> <p>Behold! I am the Collector... and I'm here to add you to my collection!</p>								
NOTES												

FILM ROMAN

THE SIMPSONS

TITLE _____ SHOW BABFOI ACT II PAGE 107

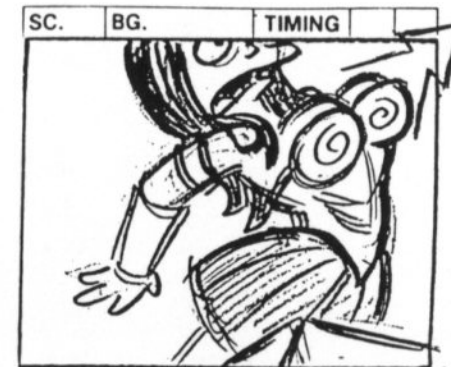
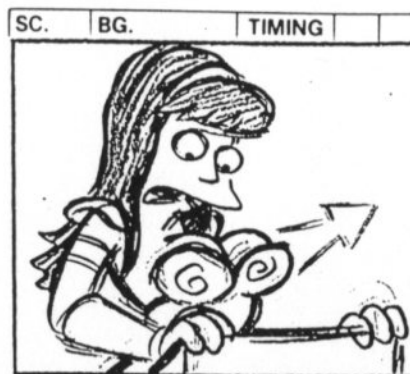
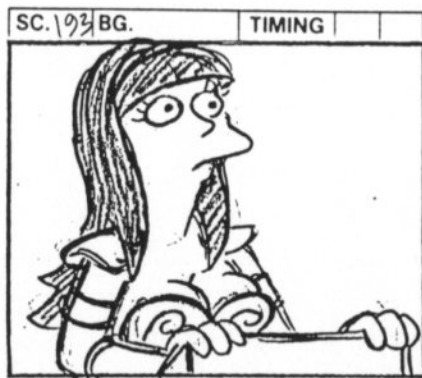
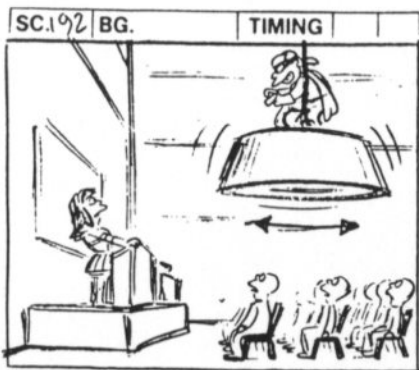

ACTION	<p>⊙ MAGNET BEGINS TO VIBRATE</p>		<p>⊙ XENA IS LIFTED OUT OF FRAME BY HER BOOBIES</p>
TRANS.			
DIAL			
TRANS.			
NOTES			

FILM ROMAN

THE SIMPSONS

TITLE _____

SHOW BABFO1

ACT II

PAGE 102

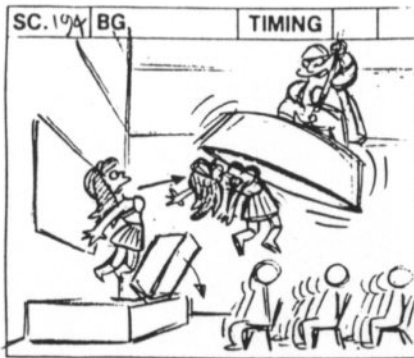

SC.	BG.	TIMING

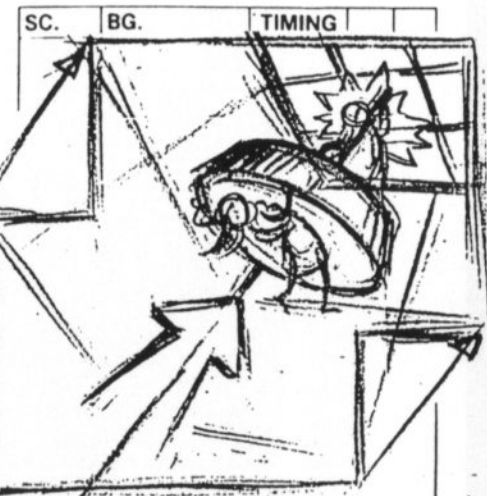
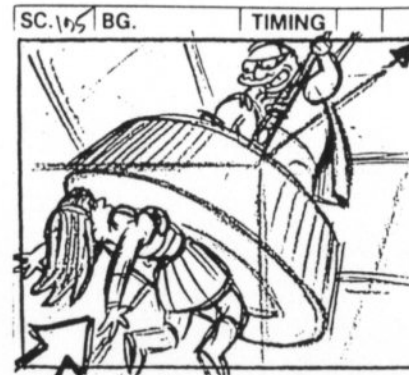

ACTION @ PODIUM IS KNOCKED OVER AS XENA GETS SUCKED UP TO THE MAGNET

... WIDEN AS XENA RISES THRU FRAME...

... ADJUST UP TO SEE

TRANS. and Xena is SUCKED ONTO the electro-magnet by her breastplate.

She **STRUGGLES** as she is lifted toward the hole in the glass roof.

THEM HEADED FOR THE HOLE IN THE GLASS

DIAL

TRANS.

NOTES

FILM ROMAN

THE SIMPSONS

TITLE _____

SHOW BABFO1

ACT II

PAGE 103

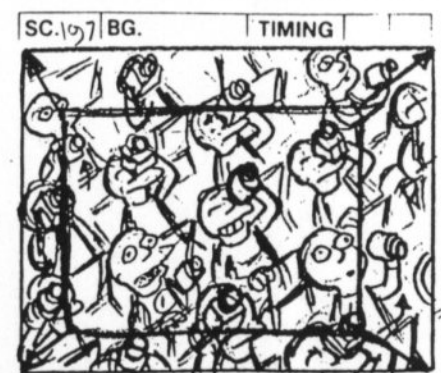
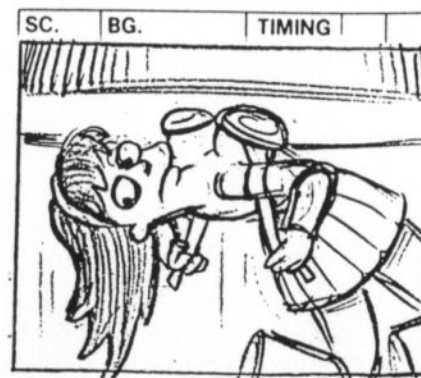
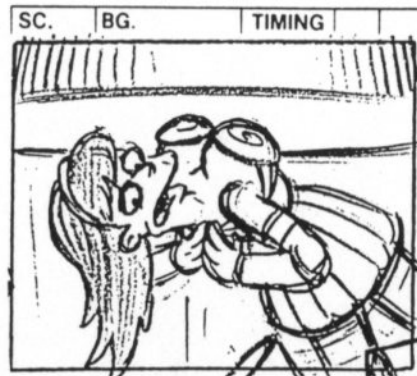
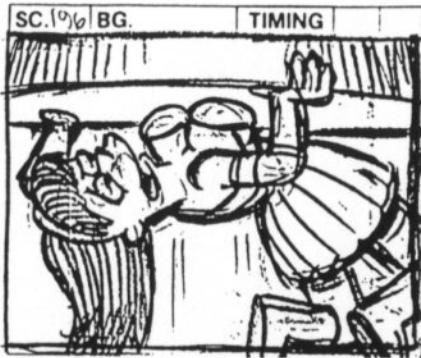

ACTION				Ⓜ SLOW PULL OUT AS PEOPLE WHIP OUT CAMCORDERS
TRANS.			She looks down to see	the nerds below her have taken out video cameras.
DIAL		LUCY LAWLESS		
TRANS.		Must remove... my breastplate...		 VIDEO CAM TO EYE WITH BIG SMILE
NOTES				

FILM ROMAN

THE SIMPSONS

197A

TITLE _____

SHOW BABFD1

ACT I

PAGE 10

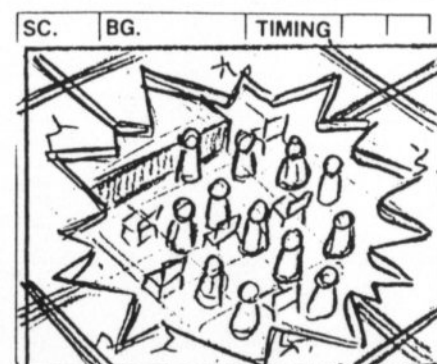
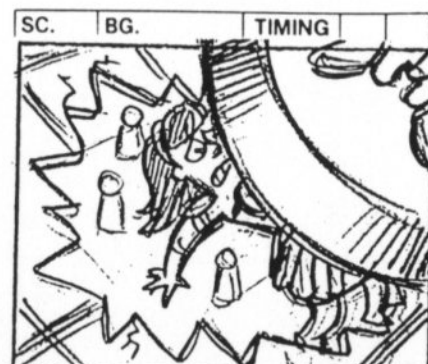
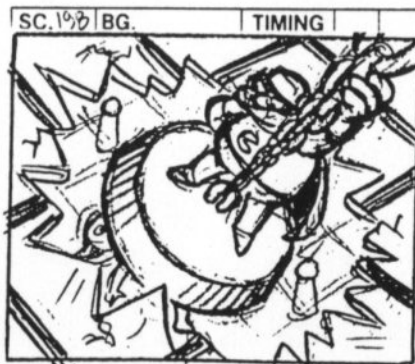

ACTION

TRANS.

DIAL

LUCY LAWLESS (CONT'D)
... Maybe later.

TRANS.

NOTES

FILM ROMAN

THE SIMPSONS

TITLE _____ SHOW BABFOI ACT II PAGE III

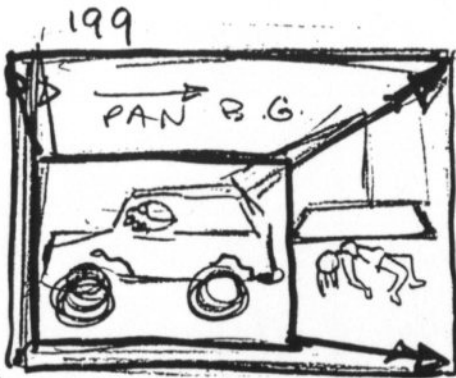

ACTION

(START) >>> | PAN | >>> (STOP)

(ANIMATE - BG)

EXT. SPRINGFIELD STREET - A LITTLE LATER

Comic Book Guy drives by in a rusty "Le Car." He tows Xena behind him, dangling from the electro-magnet.

TRANS.

DIAL

COMIC BOOK GUY
Care for a Rollo, sweet Xena?

LUCY LAWLESS
All right, "Collector," stick this in your tweezers! I'm not Xena! I'm an actress, you lunatic.

TRANS.

NOTES

FILM ROMAN

THE SIMPSONS

TITLE _____

SHOW BABFO1 ACT II

PAGE 112

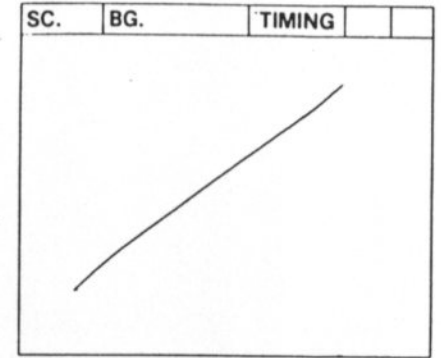
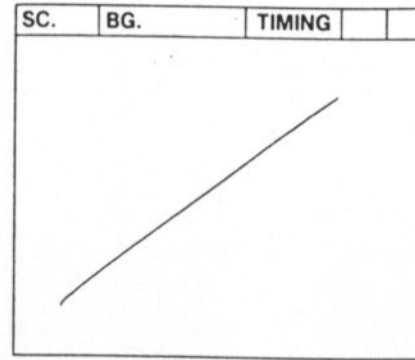
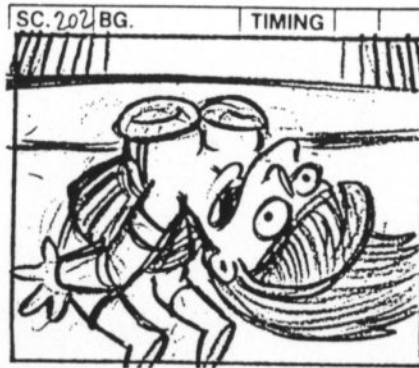
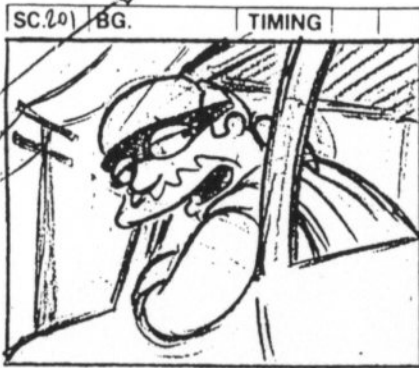

ACTION

»» | BG | —>

TRANS.

DIAL

COMIC BOOK GUY
Oh, please. I'm not insane. I simply wish to take you back to my lair and make you my bride.

LUCY LAWLESS
Oh, dear God!

TRANS.

NOTES

FILM ROMAN

THE SIMPSONS

TITLE _____

SHOW BABFOI

ACT II

PAGE 113

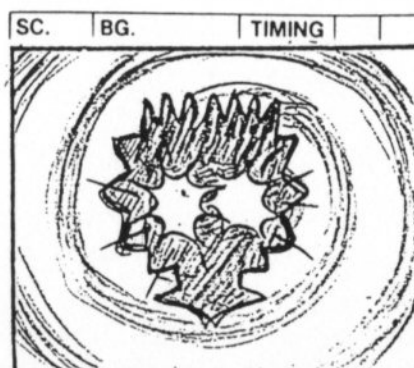
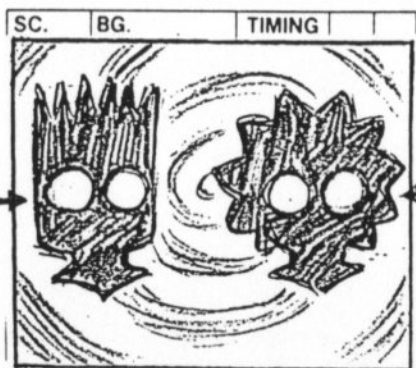
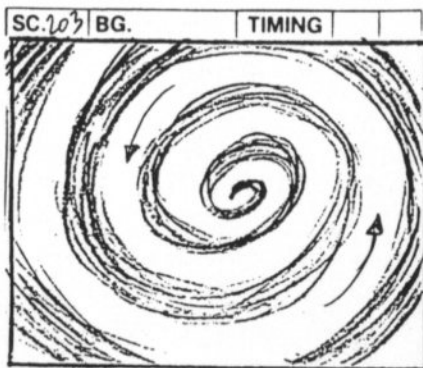

ACTION

o FUNKY SPIRAL B.G.

o HEADS FLY INTO FRAME

o D.X. EYES

TRANS.

DIAL

TRANS.

NOTES

FILM ROMAN

THE SIMPSONS

(CONT)

TITLE _____

SHOW BART!

ACT II

PAGE 114

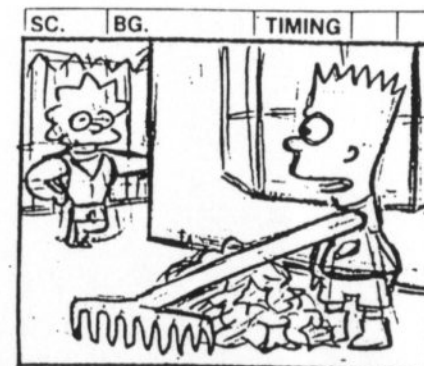
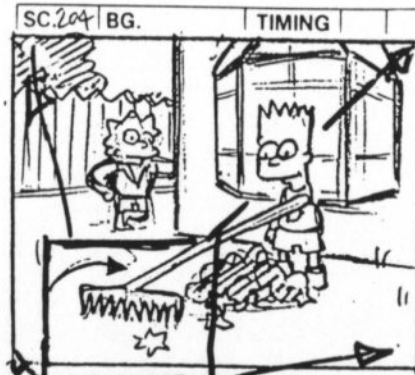
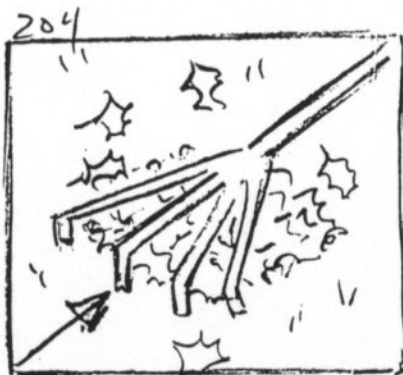

ACTIK

~~SLOW PUSH~~
PULL OUT

EXT. SIMPSONS FRONT YARD - A LITTLE LATER

Bart and Lisa are doing yard work. Bart RAKES leaves into a pile with his arm, which is stretched into a rake shape.

TRANS.

DIAL

TRANS.

BART
Clobber Girl?

NOTES

FILM ROMAN

THE SIMPSONS

TITLE _____

SHOW BABFOI

ACT II

PAGE 115

CONT

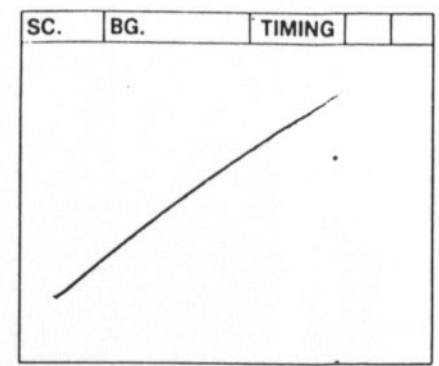
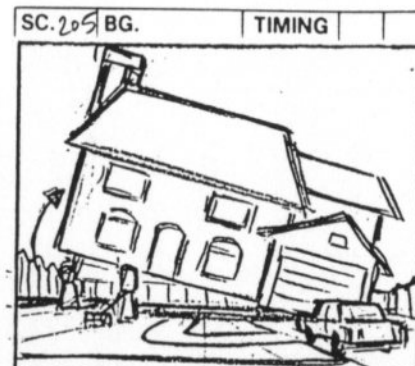
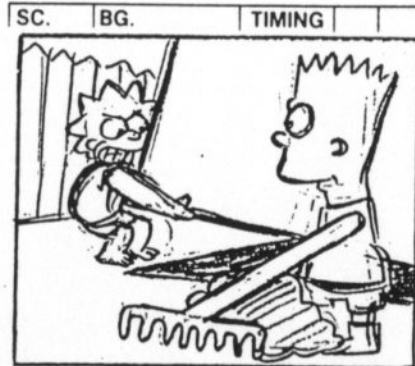
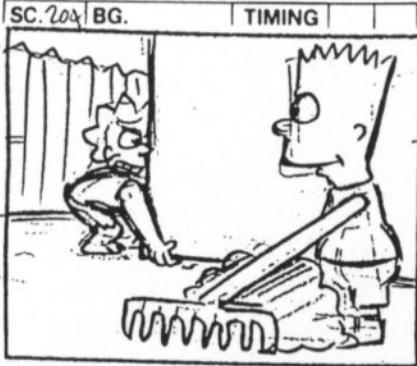

ACTION

CUT ON ACTION OF HOUSE RISING

Lisa LIFTS one corner of the house.

TRANS.

DIAL

TRANS.

NOTES

FILM ROMAN

THE SIMPSONS

TITLE _____

SHOW BABFO1

ACT II

PAGE 116

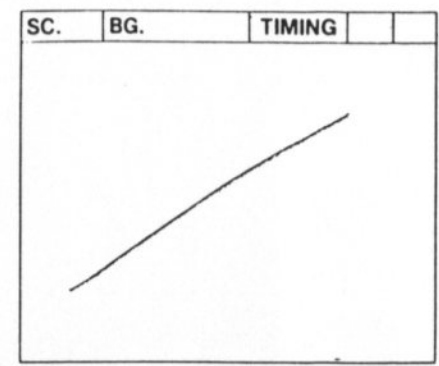
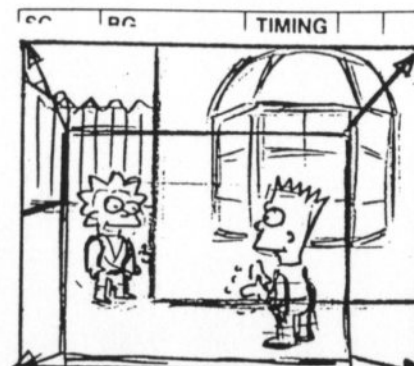
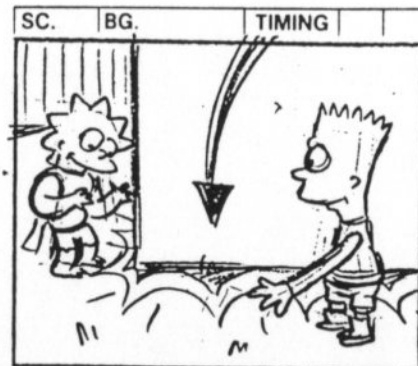
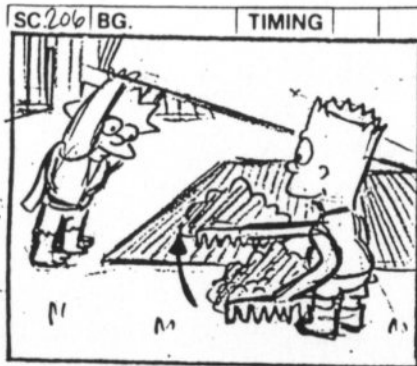

ACTION

Ⓢ BART SWEEPS PILE UNDER HOUSE

Bart quickly RAKES the leaf pile under the house,

Ⓢ LISA DROPS HOUSE

then Lisa SETS IT DOWN again.

Ⓢ HIDEV JUST AS...

BART + LISA DUST OFF HANDS

TRANS.

DIAL



TRANS.

NOTES

FILM ROMAN

THE SIMPSONS

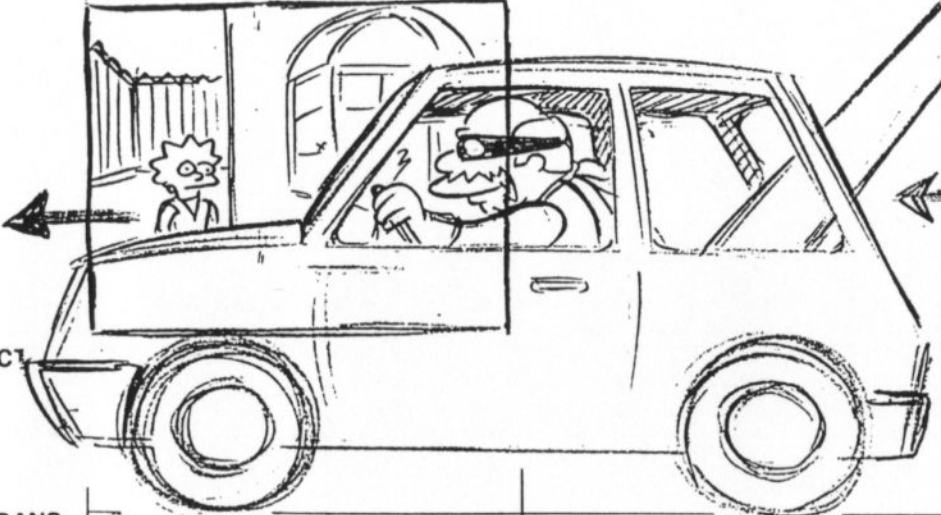
SHOW BABFO1 ACT II PAGE 117

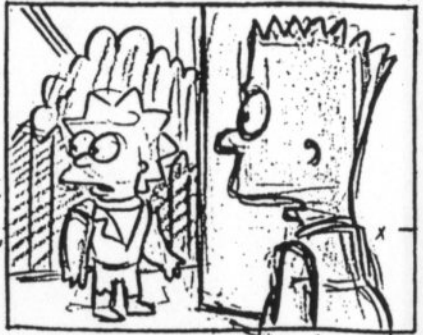
TITLE		SC. 206				SC. 207					
CONT	BG.	TIMING	SC.	BG.	TIMING	CONT	BG.	TIMING	SC.	BG.	TIMING
											
ACT											
TRANS.	<p>COMIC BOOK GUY PASSES THRU FRAME</p>										
DIAL											
TRANS.											
NOTES											

THEN XENA PASSES THRU FRAME

The Collector's car passes by with Xena in tow.

LUCY LAWLESS (O.S.)
Help!

FILM ROMAN

THE SIMPSONS

TITLE _____

SHOW BABFO1

ACT II

PAGE 119

CONT

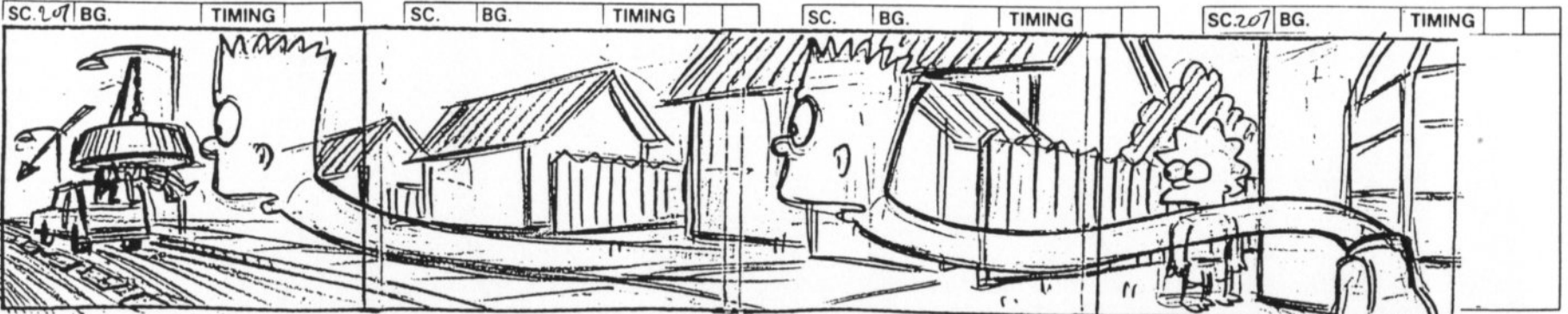

ACTION	STOP	PAN	START
	① CAR IS DRIVING AWAY	Bart STRETCHES his head out to the street.	② FOLLOW BART'S HEAD
TRANS.			
DIAL			
TRANS.			
NOTES			

FILM ROMAN

THE SIMPSONS

TITLE _____

SHOW BABFO1

ACT II

PAGE 119

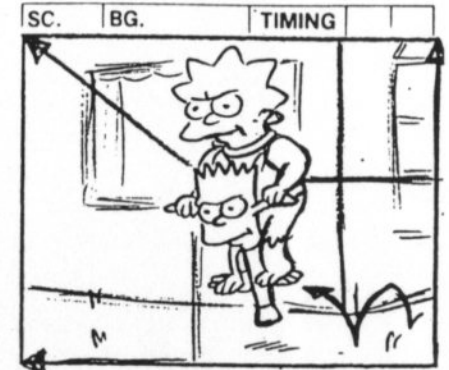
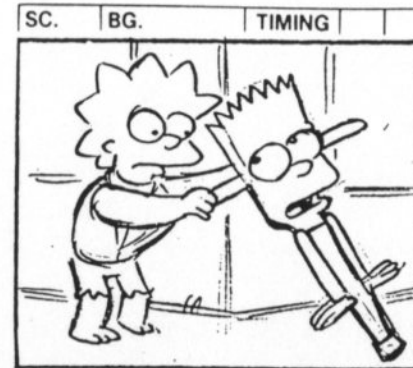
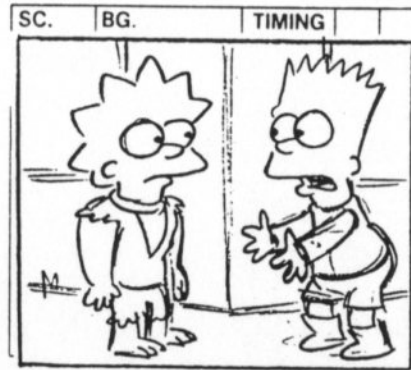
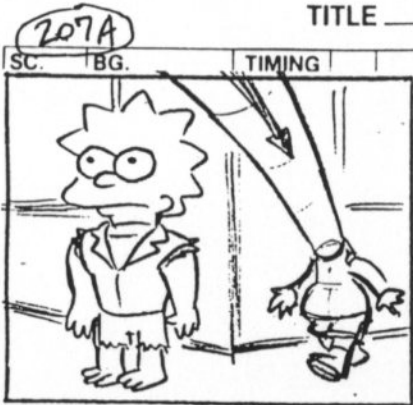

ACTION

Ⓣ BART'S HEAD COMES BACK INTO FRAME AS HE WALKS UP TO LISA

Bart turns himself into a human pogo stick.

Ⓣ WIDEN AS THEY HOP OUT OF FRAME
Lisa hops on and they bounce away.

TRANS.

DIAL

BART
It's Xena! She's been kidnapped!

Come on!

TRANS.

NOTES

FILM ROMAN

THE SIMPSONS

TITLE _____ SHOW BABFDI ACT II PAGE 120

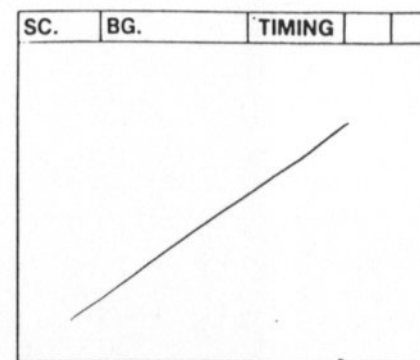
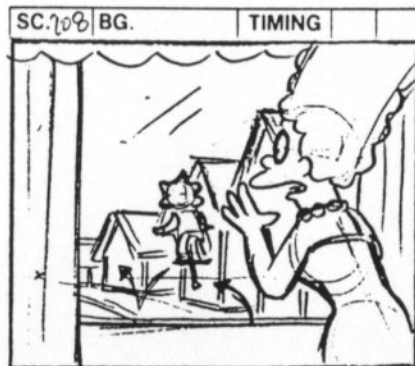

ACTION

@ MARGE RUNS INTO WINDOW FRAME

@ WE SEE BART & LISA IN P OUT OF FRAME

@ HOMER ENTERS

Homer joins her in the window.

TRANS.

Marge sticks her head out the window.

DIAL

MARGE
(CALLING AFTER THEM) Remember,

you're vulnerable to Kryptonite!

HOMER
Geez, Marge, tell the neighborhood.

TRANS.

DISSOLVE TO:

NOTES

FILM ROMAN

THE SIMPSONS

TITLE _____ SHOW BABFOI ACT II PAGE 121

SC.	BG.	TIMING	SC.	BG.	TIMING	SC.	BG.	TIMING	SC.	BG.	TIMING
-----	-----	--------	-----	-----	--------	-----	-----	--------	-----	-----	--------



ACTION

AUX OUT

TRANS.

DIAL

EXT. ANDROID'S DUNGEON - LATER - ESTABLISHING

TRANS.

NOTES

FILM ROMAN

THE SIMPSONS

TITLE _____

SHOW BABFO1

ACT II

PAGE 122

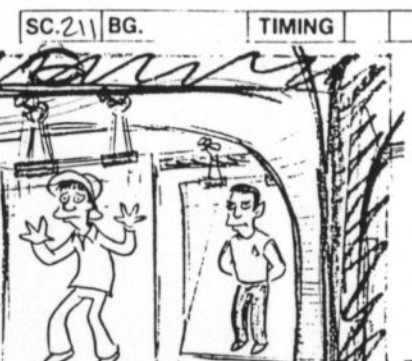
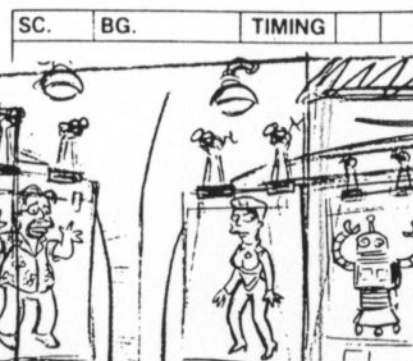
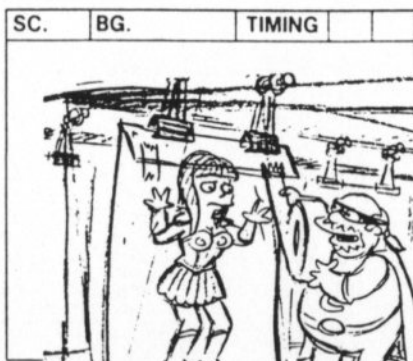
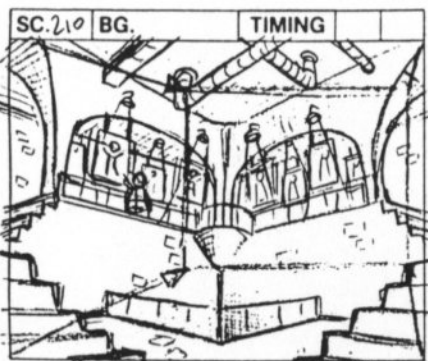

ACTION AUX OUT AUX OUT

TRUCK IN ON BODIES

STOP

PAN

(START)

TRANS.

INT. ANDROID'S DUNGEON - BACK ROOM - CONTINUOUS

Xena is inside a giant Mylar pouch, which hangs from two clips attached to the ceiling. Comic Book Guy finishes sealing the top flap of the pouch with a giant roll of tape. (Hanging nearby are other Mylar pouches with CELEBRITIES nerds love in them: Mr. Spock, Gilligan, the "Lost in Space" Robot, the Borg woman from "Voyager," and Matt Groening.)

DIAL

COMIC BOOK GUY

Fear not, my syndicated sweetie.

You'll be preserved in this Mylar

pouch. Forever remaining in

(APPRAISING HER) near-mint condition

between

TRANS.

NOTES

FILM ROMAN

THE SIMPSONS

TITLE _____

SHOW BABFOI

ACT II

PAGE 123

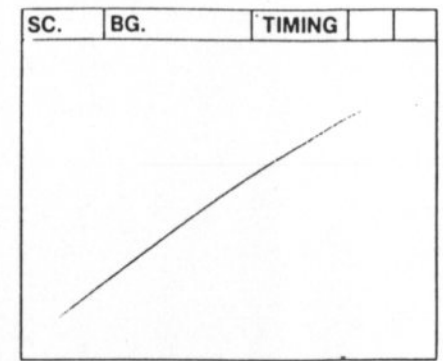
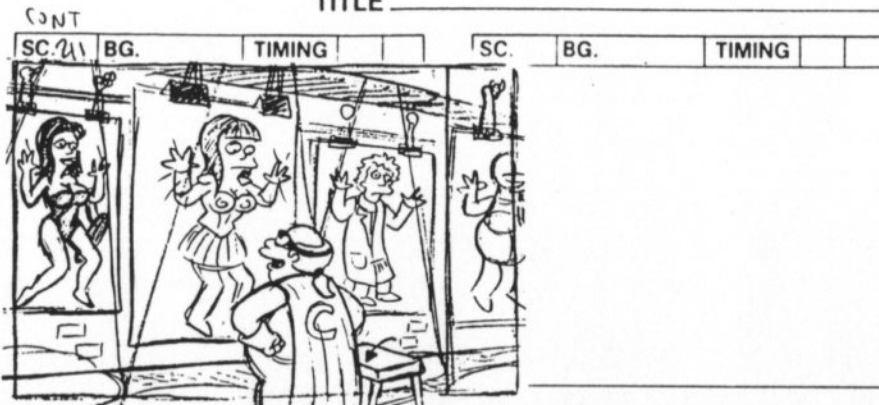

ACTION

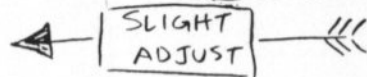

① "COLLECTOR" STEPS DOWN

Comic Book Guy whips his head around

TRANS.

TO REVEAL YASMINE
& DR. WHO

DIAL

Dr. Who and, of course, Yasmine Bleeth.

TRANS.

LISA (O.S.)
I don't think so!

NOTES

FILM ROMAN

THE SIMPSONS

TITLE _____

SHOW BABFOI

ACT II

PAGE 124

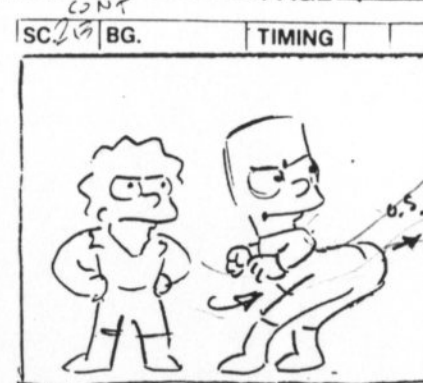
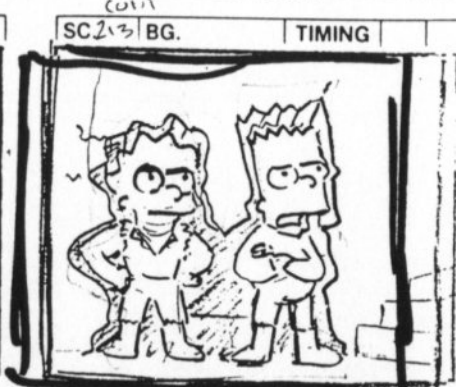
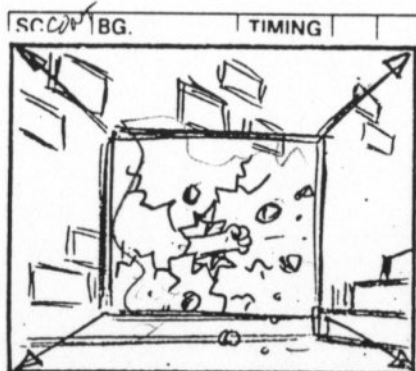

ACTION

to see Lisa PUNCH a large hole in the wall.

⊙ AS CRACKS FORM, QUICKLY PULL OUT

⊙ WALL SHATTERS

For some reason, it's a perfect outline of her and Bart. They step inside the store, arms akimbo.

TRANS.

Bart turns and quickly extends his ass across the room

DIAL

BART (~~OUT~~)

I don't think so, either.

TRANS.

NOTES

FILM ROMAN

THE SIMPSONS

TITLE _____

SHOW U

ACT II

PAGE 125

NO SC 214
NO SC 218, 219

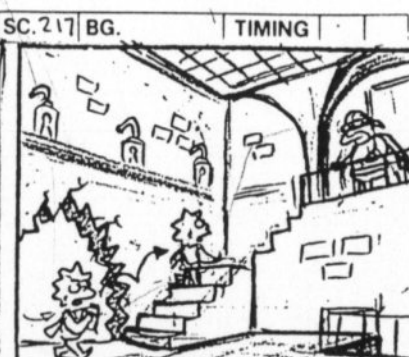
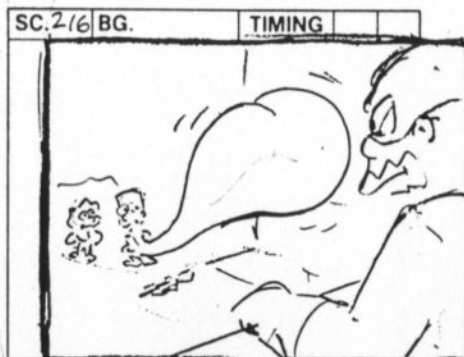
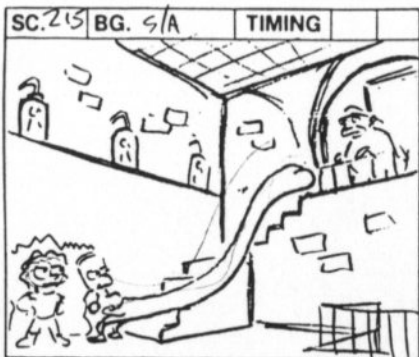

ACTION

and waggles it at Comic Book Guy.
He then retracts his ass.

WIGGLE
WIGGLE

Lisa walks toward Comic Book Guy, PUNCHING her hand with her fist.

TRANS.

DIAL

LISA

Your collecting days are over,
Collector...

TRANS.

NOTES

FILM ROMAN

THE SIMPSONS

SHOW BABF01 ACT II PAGE 126

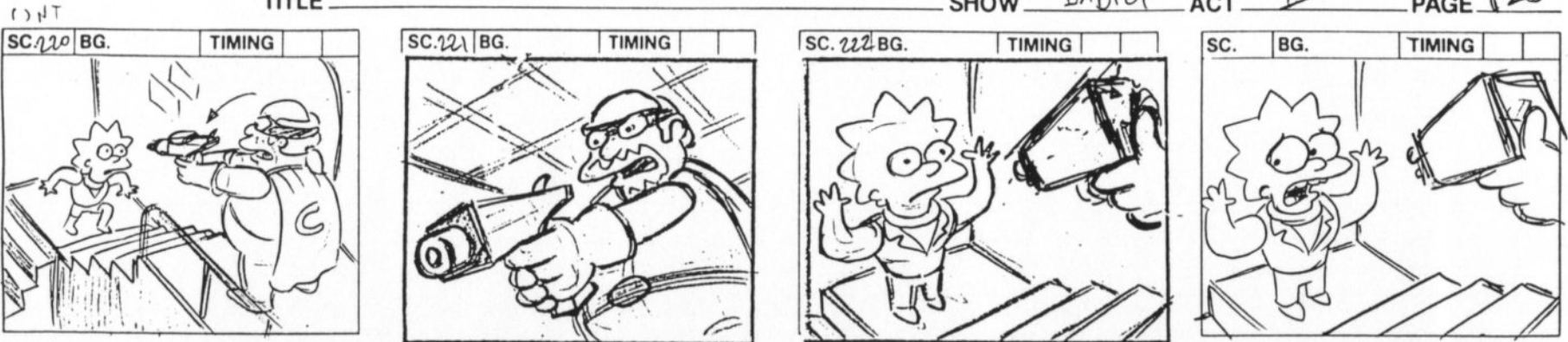

ACTION	<p>Lisa heads toward him. He grabs a phaser from off a shelf.</p>		<p>He COCKS the phaser like a revolver.</p>
TRANS.			
DIAL	<p>COMIC BOOK GUY (CONT'D) Stop right there!</p>	<p>I have here the only working phaser ever built. It was fired only once -- to keep William Shatner from making another album.</p>	<p>LISA Stretch Dude!</p>
TRANS.			
NOTES			

FILM ROMAN

THE SIMPSONS

NO PG 127-129

TITLE _____

SHOW BABFOI

ACT II

PAGE 132

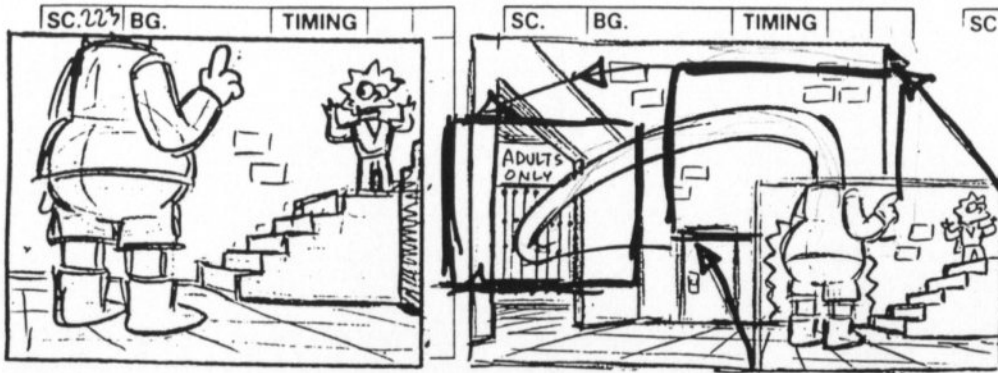

ACTION

TRUCK ALONG
BART'S NECK

WIDEN to reveal that only Bart's feet are standing next to Lisa. The rest of him has stretched into a section marked "ADULTS ONLY."

TRANS.

DIAL

Help!

TRANS.

BART (V.O.)

Just a sec.

NOTES

FILM ROMAN

THE SIMPSONS

SHOW BABFOI ACT II PAGE 131

TITLE

22A

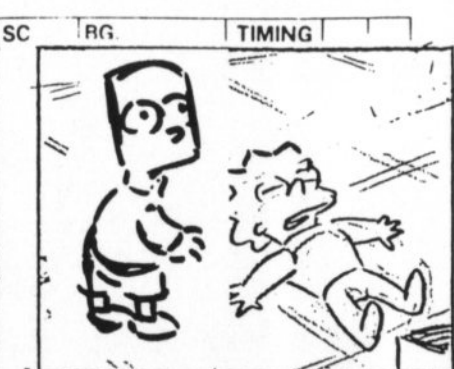
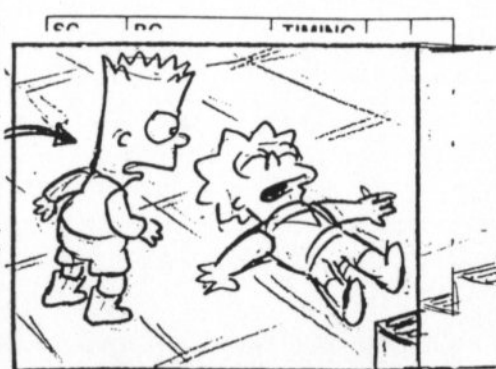
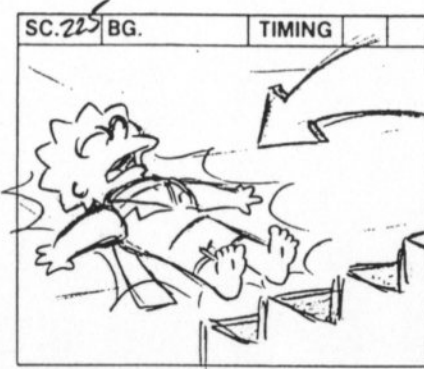
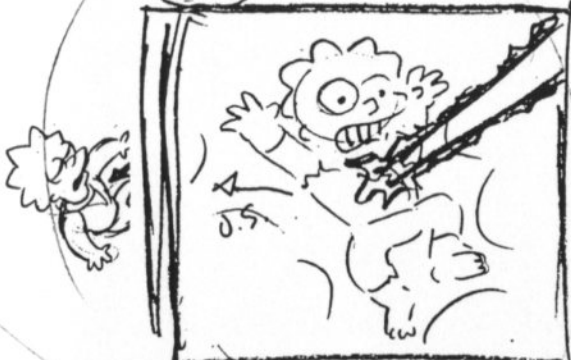

ACTION

① LISA FLIES BACK INTO WALL, & FALLS OUT OF FRAME.

② LISA FLIPS INTO FRAME

← SLIGHT ADJUST →
AS BART RUNS INTO FRAME

TRANS.

Comic Book Guy FIRES his phaser at Lisa,

KNOCKING her out.

He now FIRES his phaser at Bart, but Bart STRETCHES and dodges him.

DIAL

TRANS.

NOTES

FILM ROMAN

THE SIMPSONS

OUT

TITLE _____

SHOW BABFOI

ACT II

PAGE 133

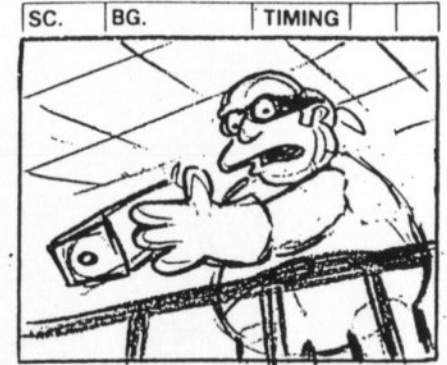
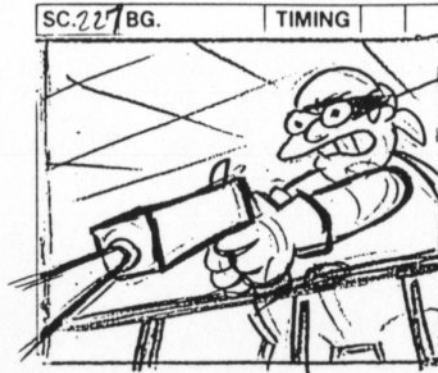
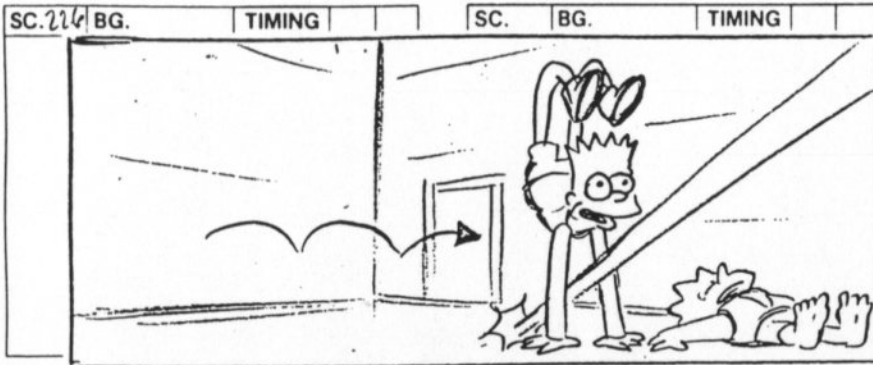

ACTION	SC. 226	SC. 227	SC. 228
	(START) → PAN → (STOP)		ON GUY The phaser runs out of power.
TRANS.			
DIAL		zing!	
TRANS.			
NOTES			

FILM ROMAN

THE SIMPSONS

CONT. TITLE _____ SHOW BABFOI ACT II PAGE 134

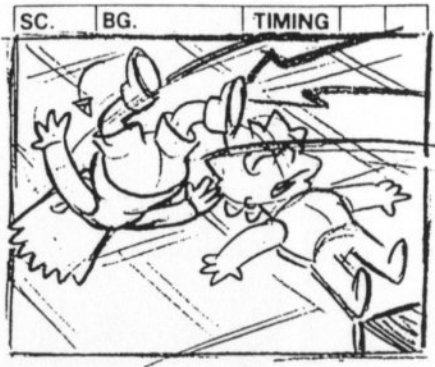
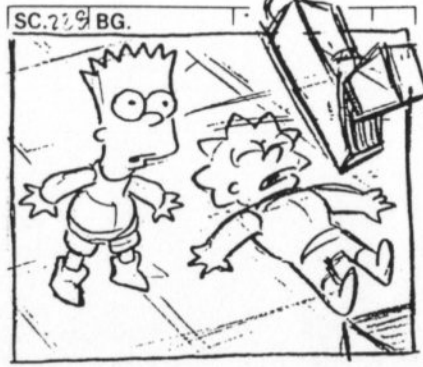
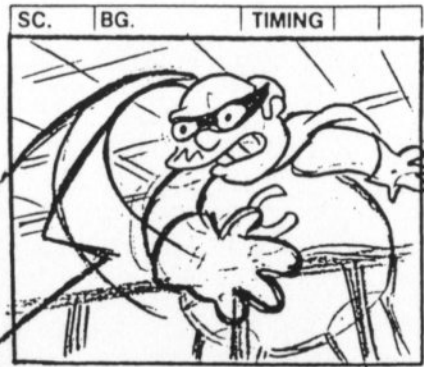
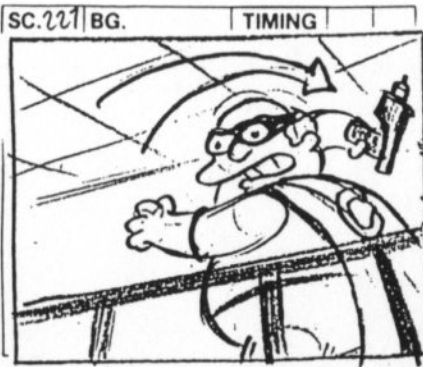

ACTION		A frustrated Comic Book Guy THROWS it at Bart.		It BEANS him in the head,
TRANS.				
DIAL				
TRANS.				
NOTES				

FILM ROMAN

THE SIMPSONS

TITLE _____

SHOW BABF01

ACT 2

PAGE 135

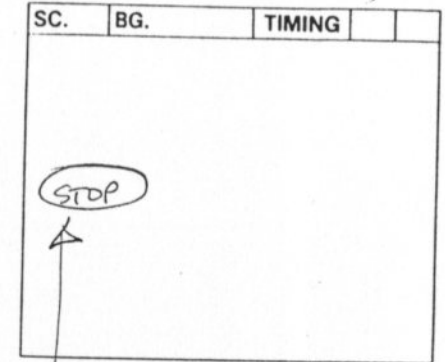
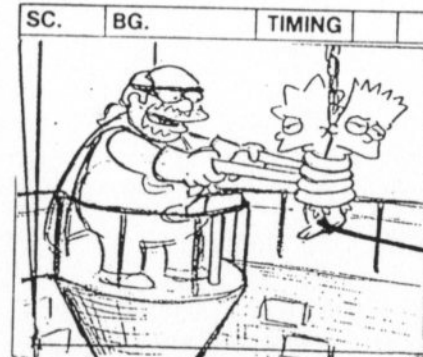
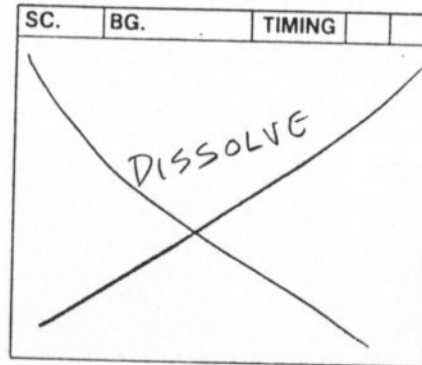
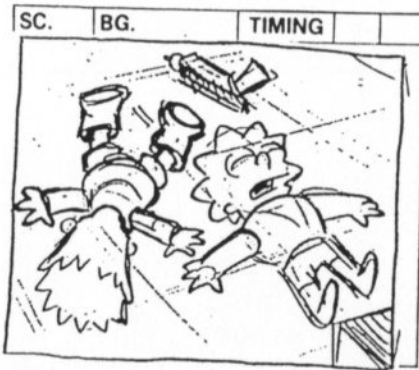

ACTION

CLOSE UP

TRANS.

of a vat of huge transparent vat of BOILING Lucite. The * word "LUCITE" is painted on the side of the vat. We PAN up to see Comic Book Guy, standing on a ladder, tying up Bart and Lisa with Bart's stretched-out body.

DIAL

TRANS.

NOTES

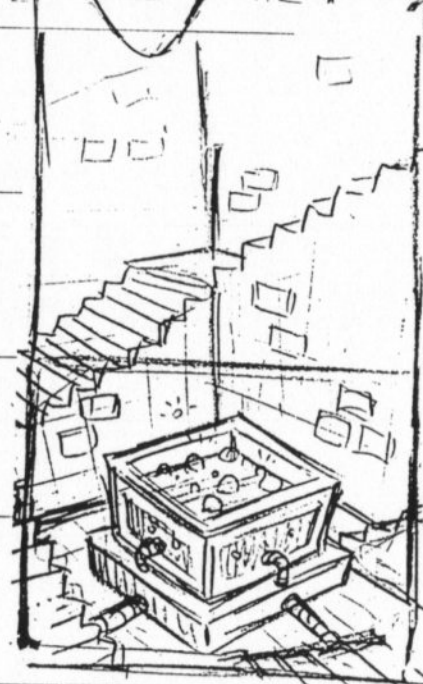

PAN

START

FILM ROMAN

THE SIMPSONS

TITLE _____

SHOW BABFO1

ACT II

PAGE 136

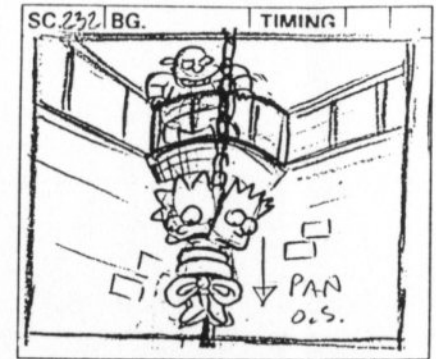
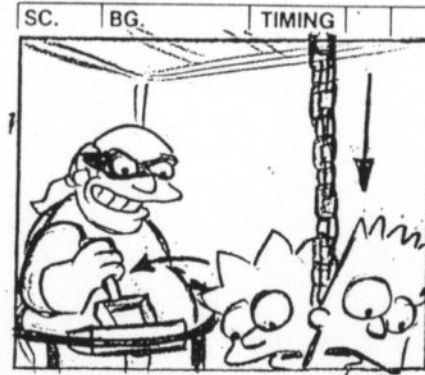
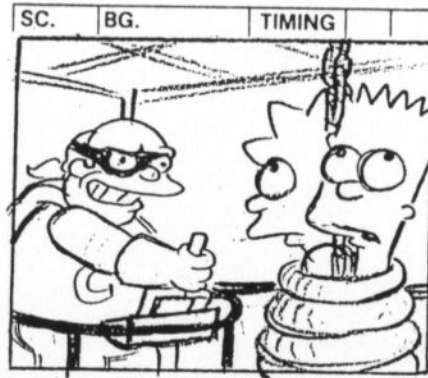
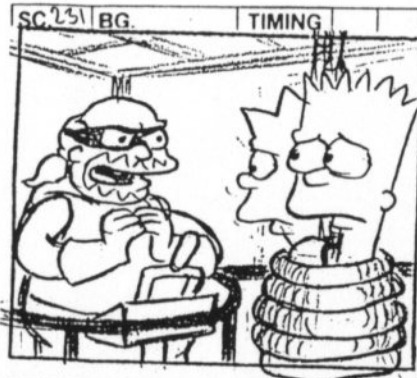

ACTION

TRANS.

DIAL

TRANS.

NOTES

			<p>CUT AWAY WHEN BART + LISA REACH BOTTOM OF FRAME</p>	<p>BART + LISA PAN DOWN, O.S.</p>
			<p>He FLIPS a switch. We hear a CLATTERING SOUND as Bart and Lisa are lowered toward the vat of Lucite. Bart and Lisa STRUGGLE.</p>	
	<p>COMIC BOOK GUY Goodnight, Retch Dude</p>	<p>and Slobber Girl.</p>	<p>COMIC BOOK GUY Sweet screams.</p>	

FILM ROMAN

THE SIMPSONS

TITLE _____

SHOW BA3F01

ACT II

PAGE 132

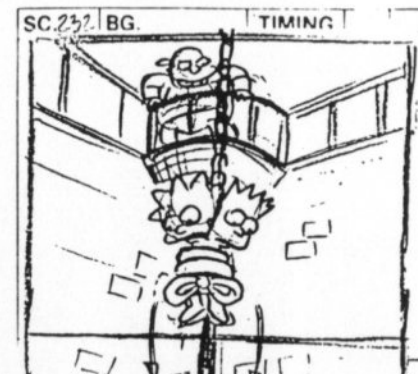
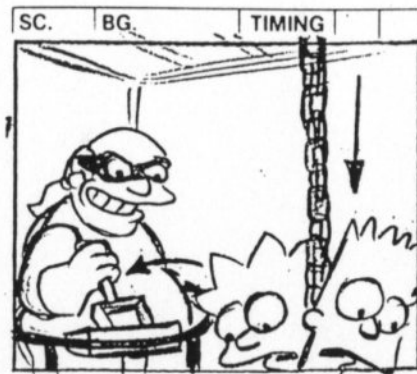
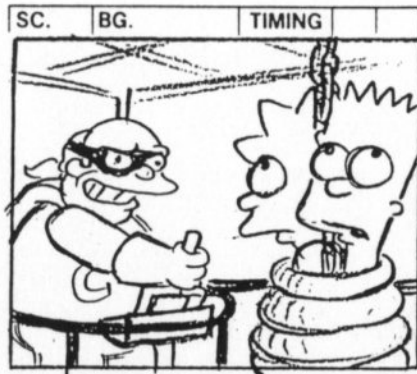
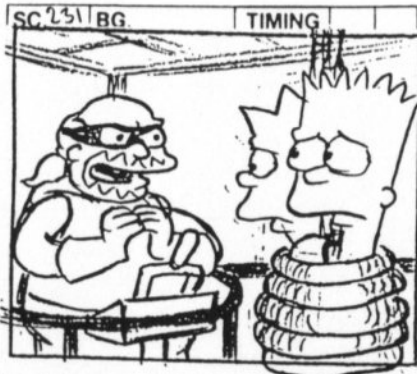

ACTION

TRANS.

DIAL

TRANS.

NOTES

BART & LISA ARE
LOWERED OUT OF
FRAME

He FLIPS a switch. We hear a CLATTERING SOUND as Bart and Lisa are lowered toward the vat of Lucite. Bart and Lisa STRUGGLE.

COMIC BOOK GUY
Goodnight, Reñch Dude

and Slobber Girl.

COMIC BOOK GUY
Sweet screams.

PAN PAST BART &
LISA TO VAT

(START)

(PAN)

(STOP)

FILM ROMAN

THE SIMPSONS

TITLE _____

SHOW BABFO1

ACT II

PAGE 137

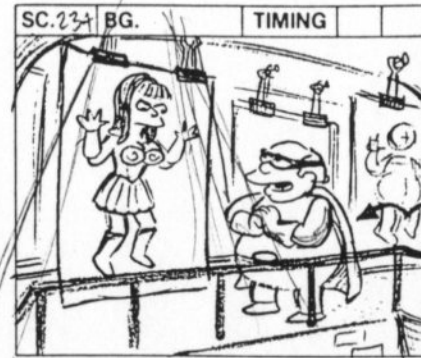
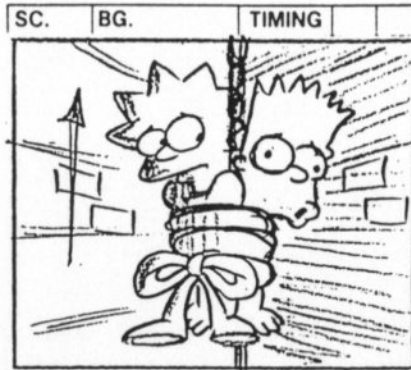
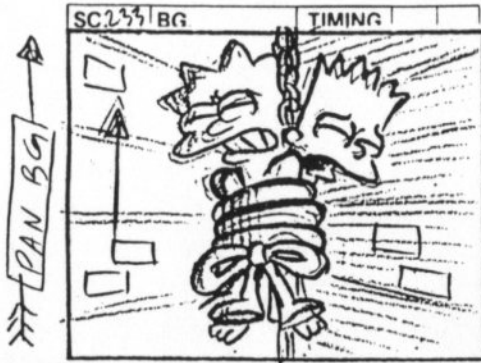

ACTION	Lisa STRUGGLES to pull free.		@ "COLLECTOR" STEPS INTO FRAME	
TRANS.	SFX: LOUD RUBBER BAND SNAP		Comic Book Guy approaches Xena, who is still in her pouch.	
DIAL	BART Ow, ow, ow!	BART (CONT'D) Oooh, that can't be good.	COMIC BOOK GUY Soon, those bratty buttinskis will be encased in Lucite for all eternity. While we're waiting, here are some names you may call me on our wedding night:	(CLEARS THROAT, THEN READS LIST) Obi-Wan, Iron Man, Mr. Mxyzptlk, and, of course, Big Papa Smurf.
TRANS.				
NOTES				

FILM ROMAN

THE SIMPSONS

TITLE _____

SHOW BABF01

ACT II

PAGE 138

	SC. 236	BG.	TIMING	SC. 237	BG.	TIMING	SC. 238	BG.	TIMING	SC. 239	BG.	TIMING
ACTION												
TRANS.							Aux out →			← Aux out		
							⊙ SLOW PUSH IN			⊙ SLOW PUSH IN		
DIAL	LUCY LAWLESS What do you need me for? You could have your choice of any of the women in these bags.			COMIC BOOK GUY You would think so, but no.			LUCY LAWLESS Really? (WARMING) Well, I mean, maybe we <u>are</u> meant for each other. Growing up, I was always tall for my age, and the other kids made fun of me.			I... I always hoped for another misunderstood soul to share my pain and...		
TRANS.												
NOTES												

FILM ROMAN

THE SIMPSONS

TITLE _____

SHOW BABFOI

ACT II

PAGE 139

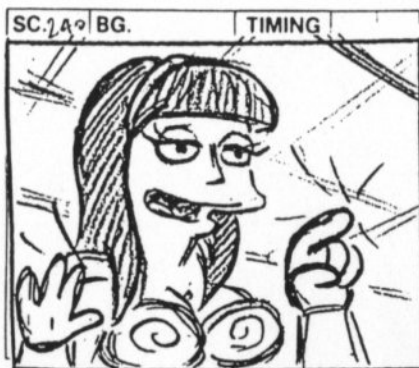

ACTION

⊙ SLIGHT PUSH IN

⊙ XENA LEANS IN

Over the preceding, we see Comic Book Guy falling helplessly in love.

TRANS.

DIAL

you could be that soul, Collector.

COMIC BOOK GUY
(LOVE-STRUCK SOUND)

LUCY LAWLESS
Come here, you. Xena needs

xex.

TRANS.

NOTES

FILM ROMAN

THE SIMPSONS

TITLE _____

SHOW BABFOI

ACT II

PAGE 142

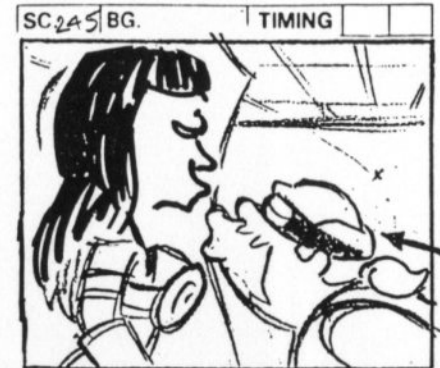
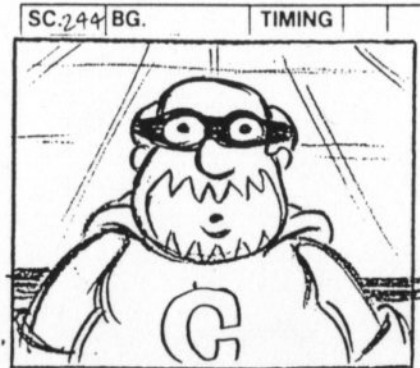
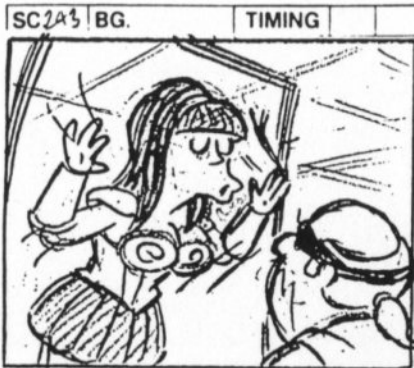

ACTION	Xena PUCKERS up.	XENA'S POV Comic Book Guy PUCKERS and leans in, looking extremely unappealing.	• "COLLECTOR" LEANS IN BACK TO SCENE His lips press against the Mylar.
TRANS.			
DIAL			
TRANS.			
NOTES			

FILM ROMAN

THE SIMPSONS

SHOW BABFOI

ACT II

PAGE 141

CONT

TITLE

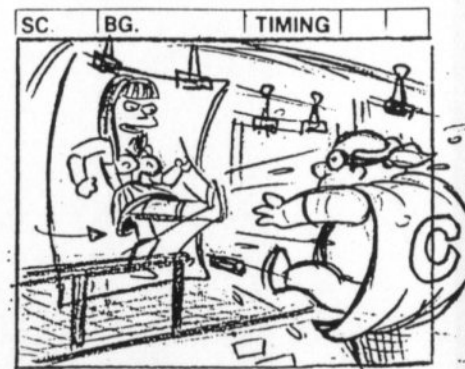
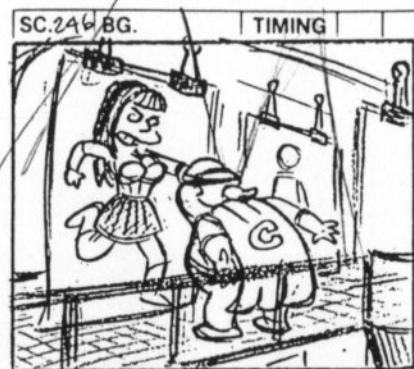
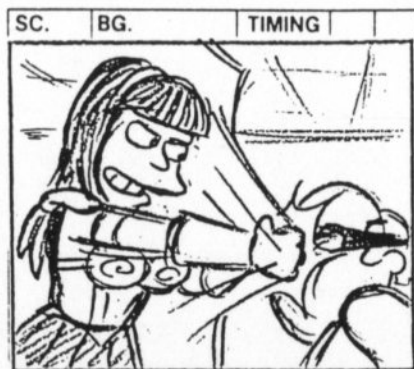
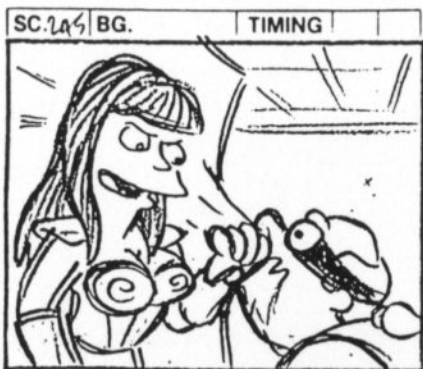

ACTION	SC. 245	SC.	SC. 246	SC.
<p>Suddenly, Xena grabs his lips in her fist.</p>	<p>@ CYCLE QUICK PUNCHES</p> <p>With her other hand, she RABBIT PUNCHES him in the face.</p>	<p>She plants a foot on his belly and KICKS him</p>	<p>@ 'COLLECTOR' FLIES OUT OF FRAME</p>	
TRANS.				
DIAL	<p>LUCY LAWLESS</p> <p>Got your lips!</p>	<p>COMIC BOOK GUY</p> <p>(RAPID SHORT PAINED SOUNDS)</p>		
TRANS.				
NOTES				

FILM ROMAN

THE SIMPSONS

TITLE _____

SHOW BABFOI

ACT II

PAGE 142

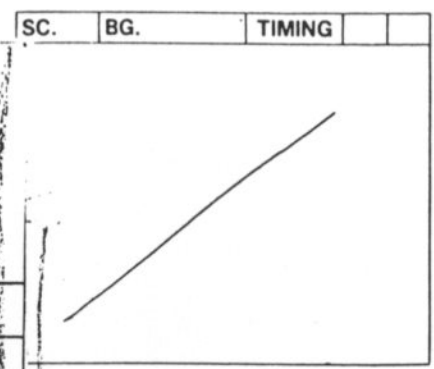
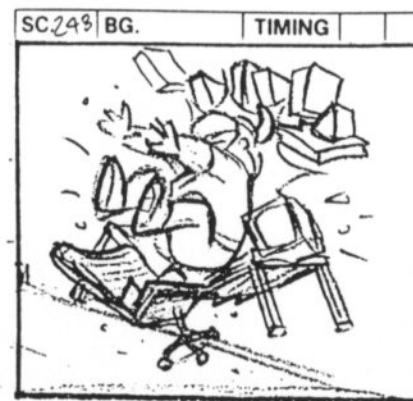
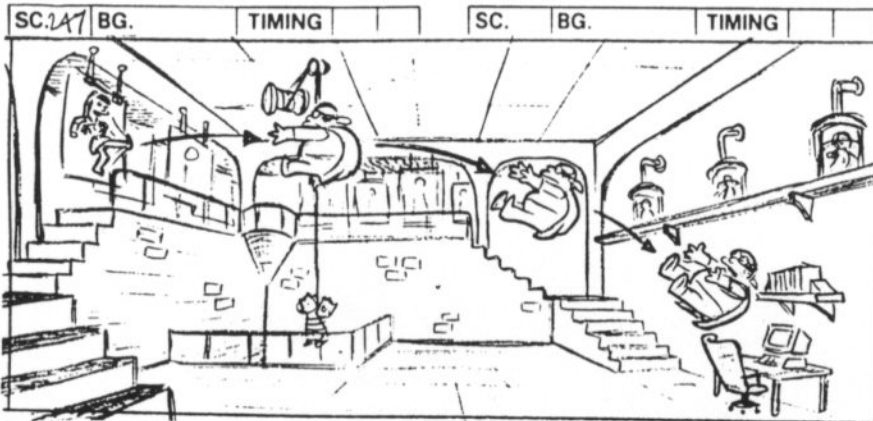

ACTION

(START) >>> [PAN] >>> (STOP)

① "COLLECTOR" CRASHES THROUGH DESK

TRANS.

across the room.

DIAL

TRANS.

NOTES

FILM ROMAN

THE SIMPSONS

TITLE _____ SHOW BABFOI ACT II PAGE 143

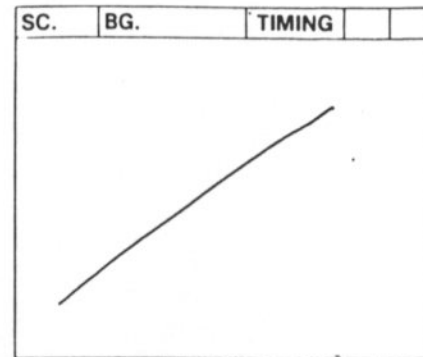
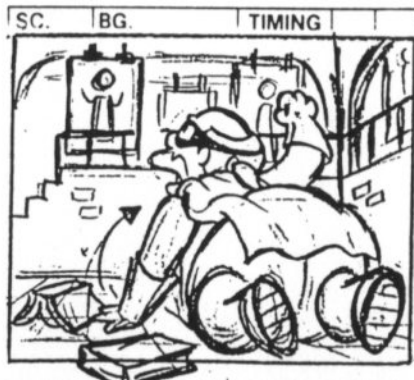
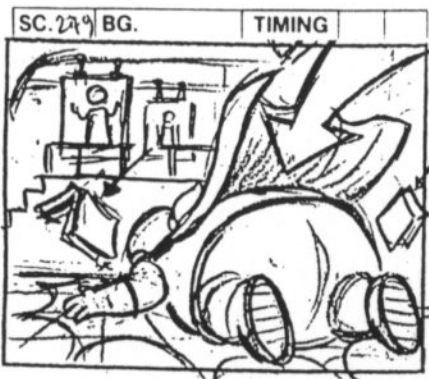

ACTION	<p>① "COLLECTOR" FLIPS INTO FRAME ALONG WITH BOOKS & DEBRIS</p>			
TRANS.				
DIAL	<p>COMIC BOOK GUY (CONT'D) (PAINED SOUNDS)</p>	<p>You tricked me</p>	<p>with a ruse so hackneyed it would make Stan Lee blush.</p>	
TRANS.				
NOTES				

FILM ROMAN

THE SIMPSONS

TITLE _____

SHOW BA3F01

ACT II

PAGE 144

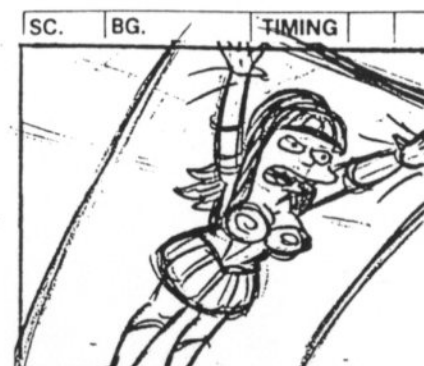
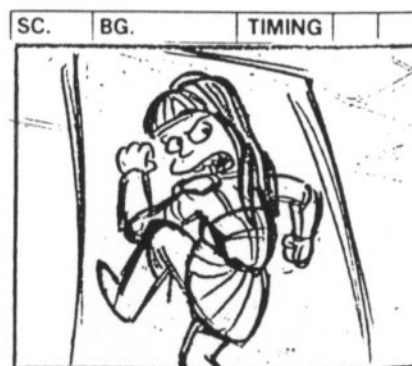
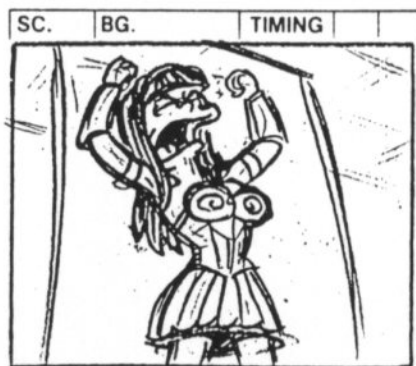
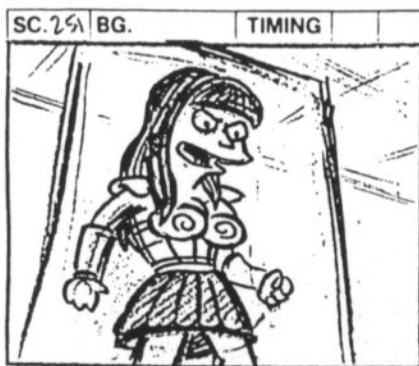

ACTION			
TRANS.			
DIAL	LUCY LAWLESS Shut up.	(ULULATING WAR CRY)	
TRANS.			
NOTES			

FILM ROMAN

THE SIMPSONS

TITLE _____

SHOW BABFOI

ACT II

PAGE 145

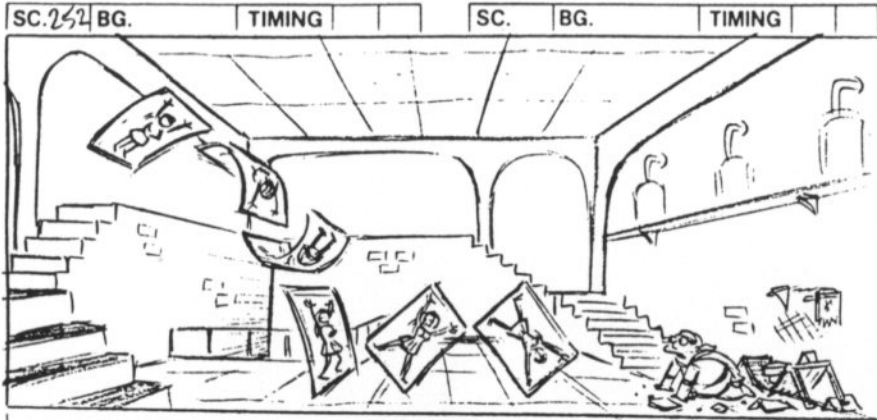

ACTION

(START) >>> [PAN] >>> (STOP)

TRANS.

DIAL

TRANS.

NOTES

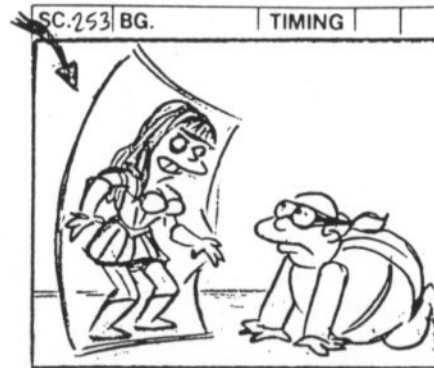

⊙ XENA LANDS IN FRAME

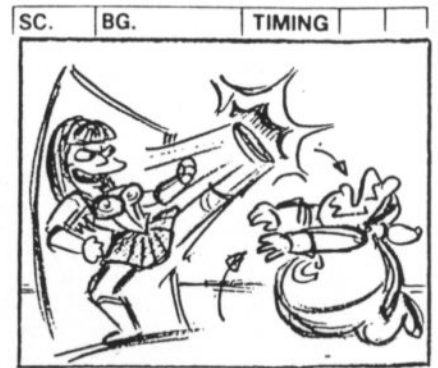

Xena, still in the bag, cartwheels across the room and starts **WAILING** on Comic Book Guy with several Xena-style moves.

FILM ROMAN

THE SIMPSONS

TITLE _____

SHOW BABFOI

ACT II

PAGE 146

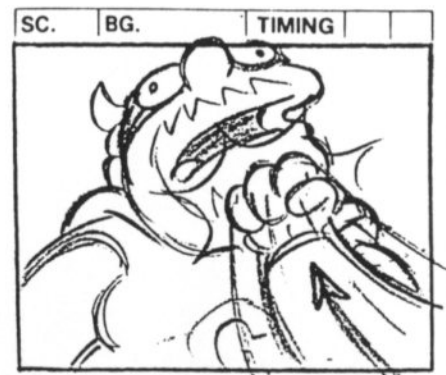
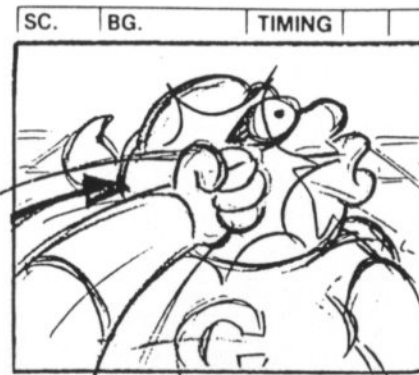
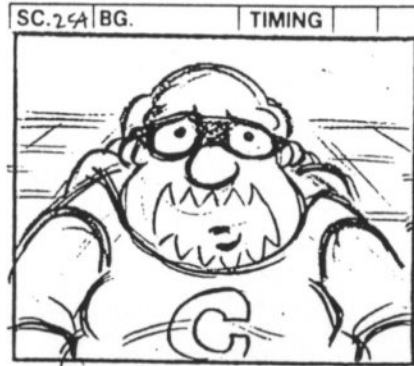

ACTION				
TRANS.				
DIAL				
TRANS.	LUCY LAWLESS (CONT'D) (ATTACKING SOUNDS)		COMIC BOOK GUY Ooh!	Ow!
NOTES				

FILM ROMAN

THE SIMPSONS

TITLE _____

SHOW BABFOI

ACT II

PAGE 147

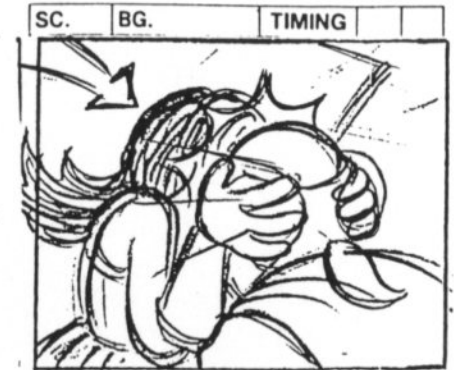
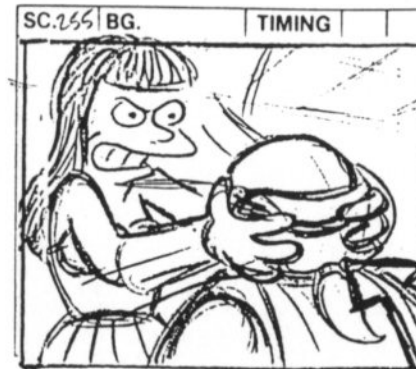
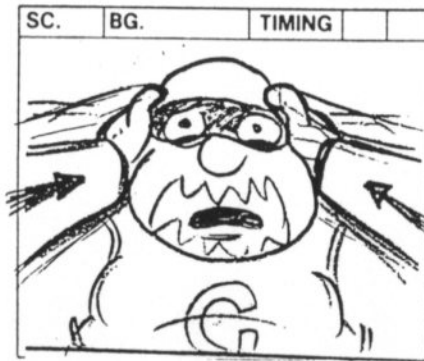
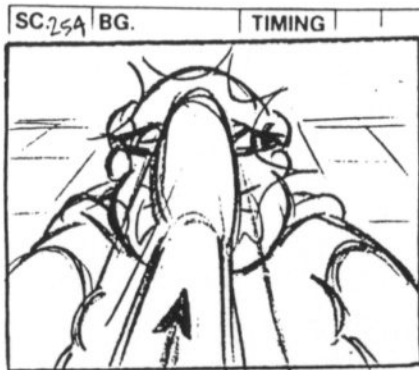

ACTION

TRANS.

DIAL

TRANS.

NOTES

Oh, that hurts!

FILM ROMAN

THE SIMPSONS

TITLE _____

SHOW BABFOI ACT II PAGE 143

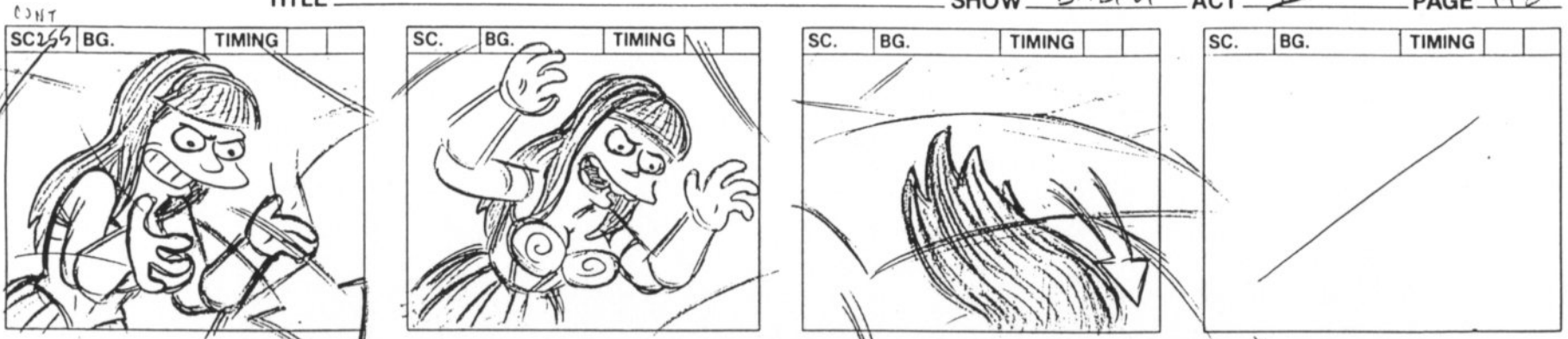

ACTION	<p>① "COLLECTOR" FALLS OUT OF FRAME</p>	<p>② XENA DIVES AFTER HIM</p>		
TRANS.				
DIAL				
TRANS.				
NOTES				

FILM ROMAN

THE SIMPSONS

SHOW BABFO1 ACT II PAGE 143

TITLE

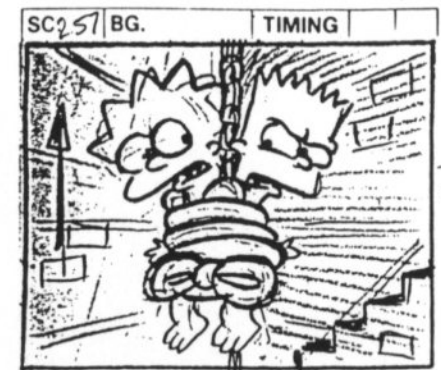
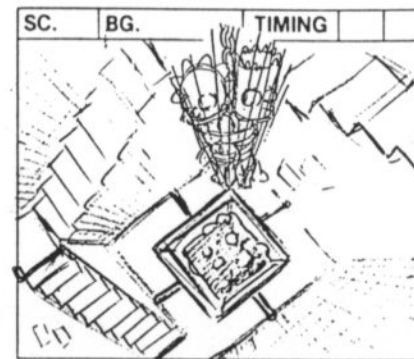
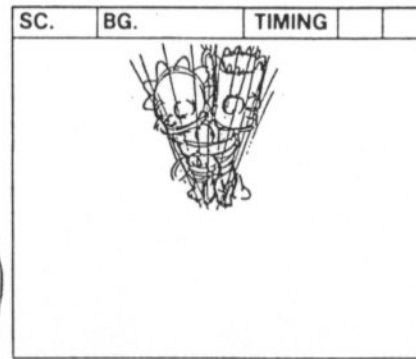
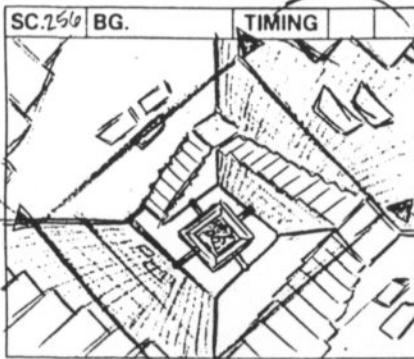

DAN BG

ACTION	<p>Twist in</p> <p>BI-PACK</p> <p>WILL LOOK LIKE THIS</p>		
TRANS.		<p>ANGLE ON BART AND LISA</p> <p>They are RATCHETING ever closer to the boiling vat.</p>	
DIAL			<p>LISA</p> <p>Bart, just let me drop and save yourself!</p>
TRANS.			<p>BART</p> <p>(WRIGGLING) What d'you think I've been tryin' to do?</p>
NOTES			

FILM ROMAN

THE SIMPSONS

TITLE _____

SHOW BABFOI ACT II PAGE 152

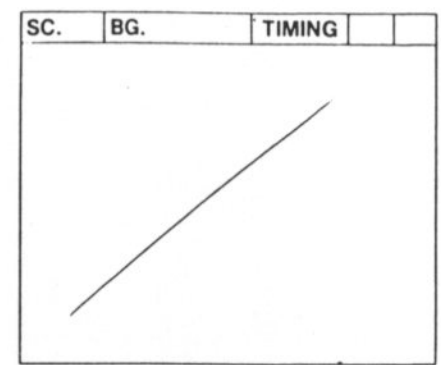
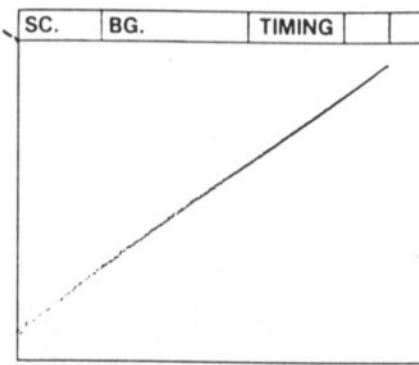
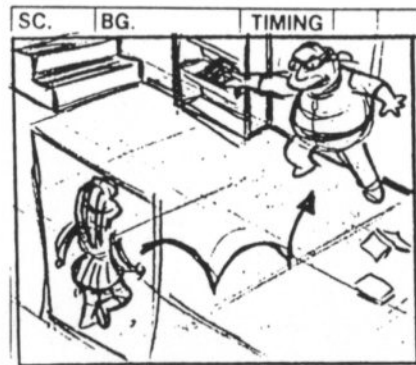
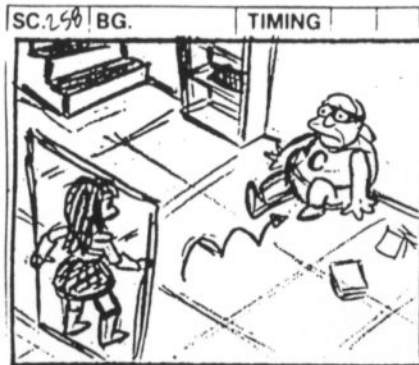

ACTION	<p>① "COLLECTOR" BACKS INTO WALL...</p>	<p>① ... AND GRABS PACKAGE</p> <p>① XENA GOES AFTER HIM...</p>		
TRANS.	<p>BACK TO SCENE</p> <p>Comic Book Guy is retreating from the rampaging Xena when he grabs something off a store shelf.</p>			
DIAL			<p>COMIC BOOK GUY</p> <p>Aha!</p>	
TRANS.				
NOTES				

FILM ROMAN

THE SIMPSONS

TITLE _____

SHOW BABFO1

ACT II

PAGE 151

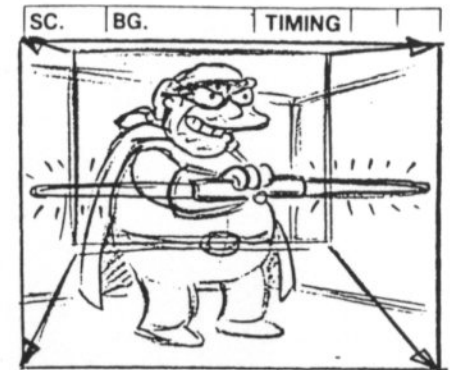
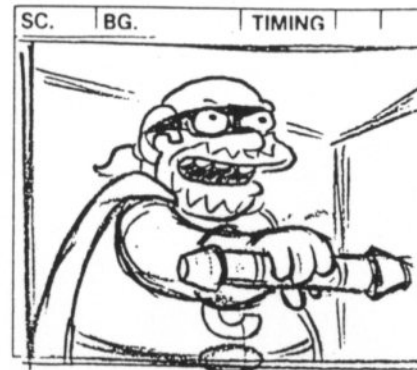

ACTION				<p>QUICK PULL OUT w/ LIGHT-SABER and turns it on.</p>
TRANS.			<p>He TEARS it free from the blister pack</p>	<p>It glows and HUMS.</p>
DIAL	<p>Not even Xena is a match for the limited-edition, double-edged light saber</p>	<p>from "Star Wars -- Episode 1...</p>	<p>The Phantom Menace".</p>	
TRANS.				
NOTES				

FILM ROMAN

THE SIMPSONS

TITLE _____

SHOW BABFO1

ACT II

PAGE 152

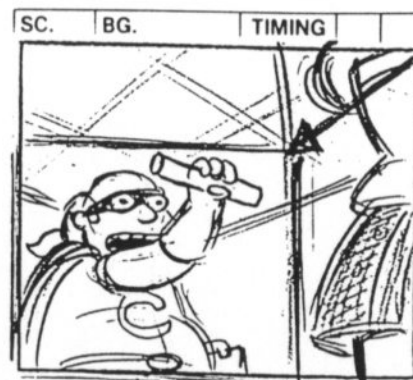
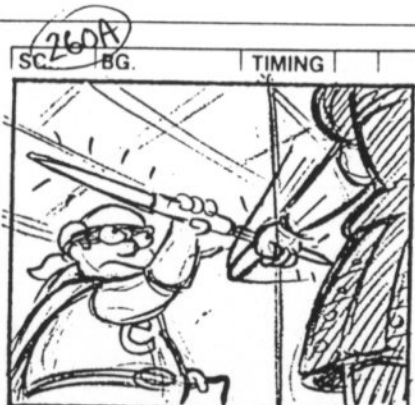
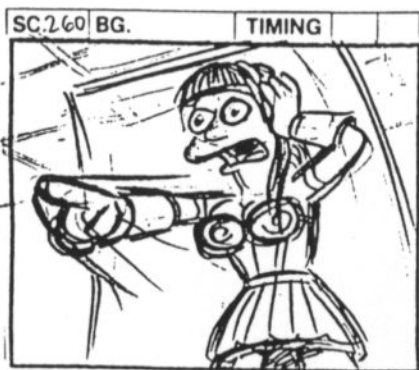

ACTION

TRANS.

DIAL

TRANS.

NOTES

● PUSH IN AS [AUX OUT] →
"COLLECTOR" TURNS OFF
LIGHT SABER

LUCY LAWLESS
(HORRIFIED GASP) You removed it from
its original packaging!

COMIC BOOK GUY
(BIGGER HORRIFIED GASP)

Nooo!

FILM ROMAN

THE SIMPSONS

(260 B)

TITLE _____

SHOW BAFFD!

ACT 2

PAGE 152A

(New)

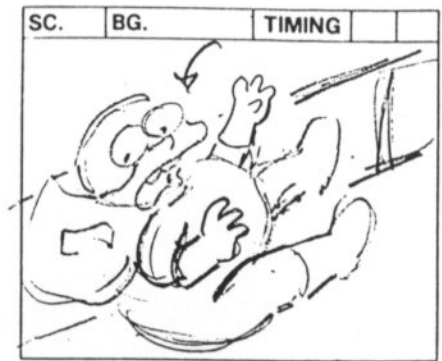
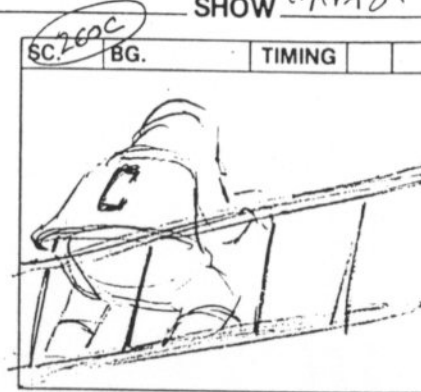
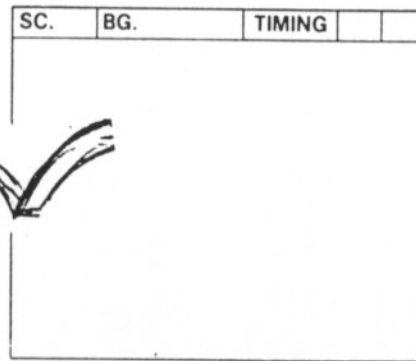
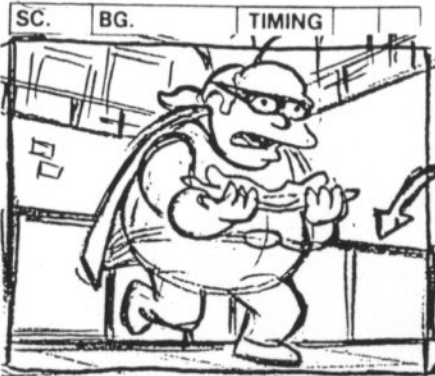

ACTION	<p>He cradles the torn package in his arms lovingly and staggers backwards.</p>		
TRANS.			
DIAL	<p>I've joined the Dark Side.</p>	<p>COMIC BOOK GUY (CONT'D) (DISTRAUGHT SOUNDS)</p>	
TRANS.			
NOTES			

FILM ROMAN

THE SIMPSONS

TITLE _____

SHOW BATSFOL

ACT II

PAGE 152

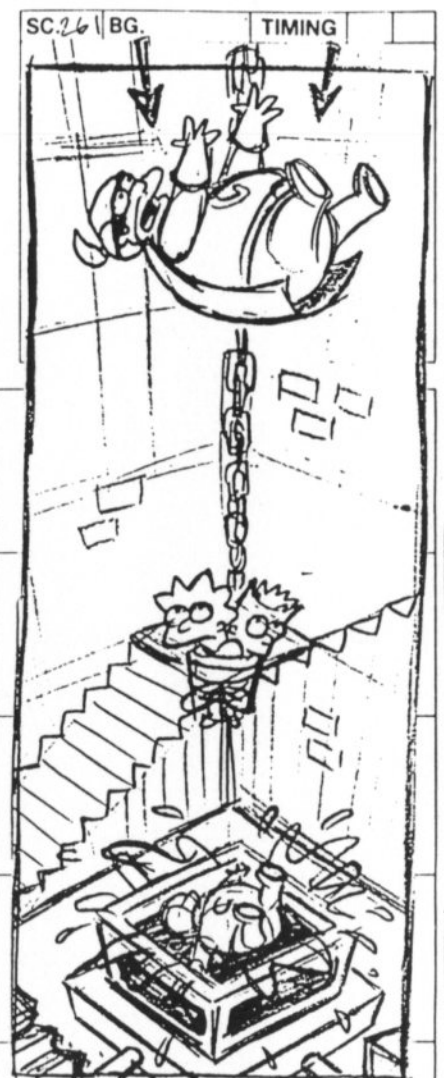
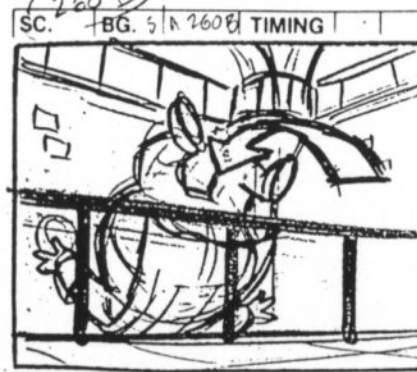
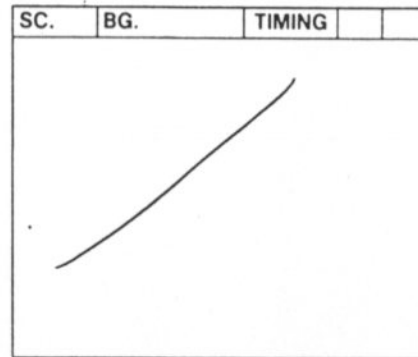
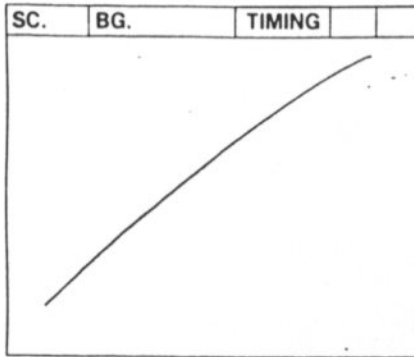

ACTION

TRANS.

DIAL

TRANS.

NOTES

He backs into the vat of boiling Lucite.

COMIC BOOK GUY (CONT'D)
(ANGUISHED CRY)

"COLLECTOR" ENTERS
FRAME & FALLS

151512 - I DANN - 111 (STAGE)

FILM ROMAN

THE SIMPSONS

TITLE _____

SHOW _____

ACT _____

PAGE 154

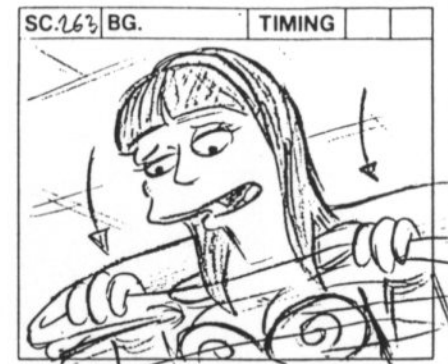
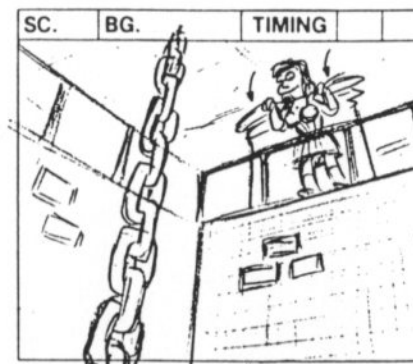
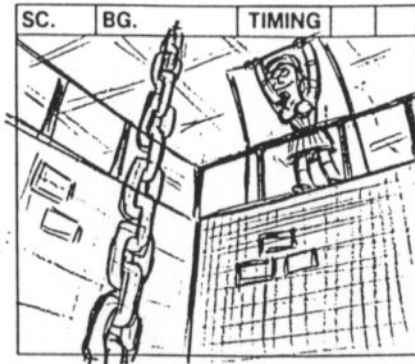
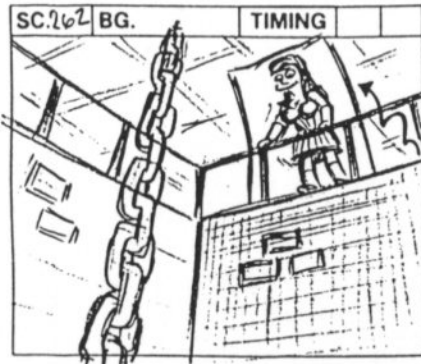

ACTION

YENA RUNS UP TO
RAILING

ANGLE ON LUCY LAWLESS

TRANS.

She frees herself from the Mylar bag.

DIAL

LUCY LAWLESS

What a nerd.

TRANS.

NOTES

FILM ROMAN

THE SIMPSONS

TITLE _____

SHOW BABFOI ACT II PAGE 155

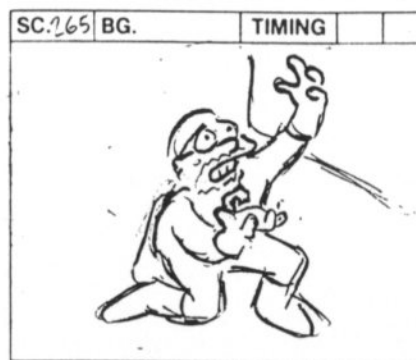
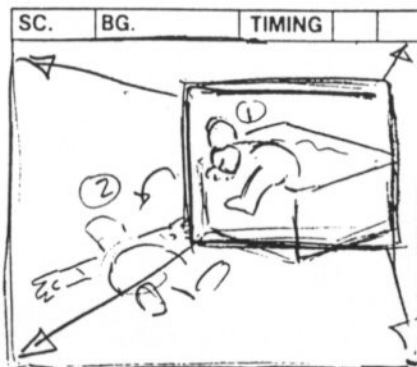
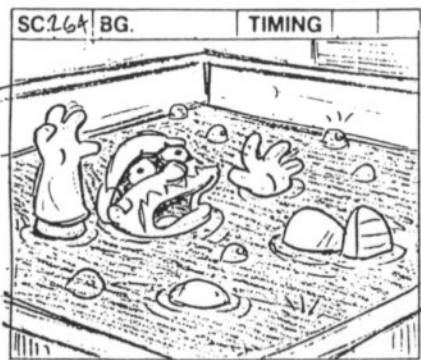

ACTION

TRANS.

DIAL

TRANS.

NOTES

<p>ANGLE ON</p> <p>Comic Book Guy, slowly congealing in the Lucite.</p>	<p>He slowly starts climbing out of the vat, coated in hardening Lucite.</p>		<p>Comic Book Guy slowly WRENCHES himself into a dramatic pose with his arms outstretched, his hands in a 'claw-like, beseeching gesture to the heavens. He then FREEZES forever.</p>
<p>COMIC BOOK GUY</p> <p>Lucite hardening...</p>	<p>COMIC BOOK GUY (CONT'D)</p> <p>Must end life in classic Lorne Greene pose from "Battlestar Galactica"...</p>		<p>COMIC BOOK GUY</p> <p>Best... death... ever.</p>

FILM ROMAN

THE SIMPSONS

TITLE _____

SHOW BABFO1

ACT II

PAGE 156

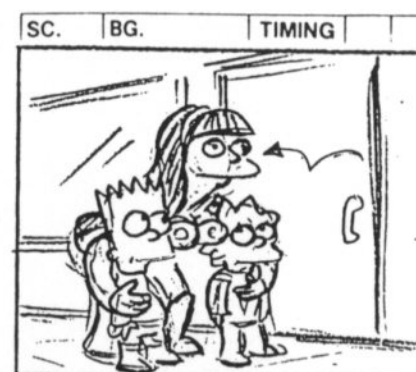
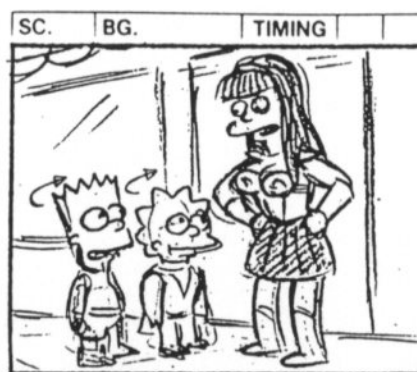
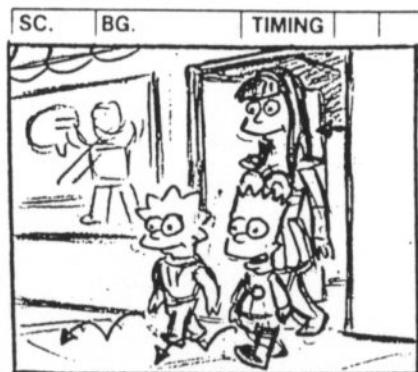
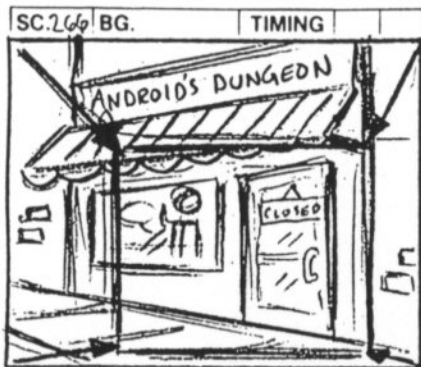

ACTION

⊙ SLOW TRUCK IN

⊙ THEY EXIT STORE

EXT. ANDROID'S DUNGEON - LATER

Bart, Lisa, and Lucy Lawless stand outside.

She scoops up Bart and Lisa under her arms

TRANS.

DIAL

thanks for saving us.

BART

LUCY LAWLESS

Wow,

No problem. Now let's get you kids home.

TRANS.

NOTES

FILM ROMAN

THE SIMPSONS

SHOW BABFOI ACT II PAGE 157

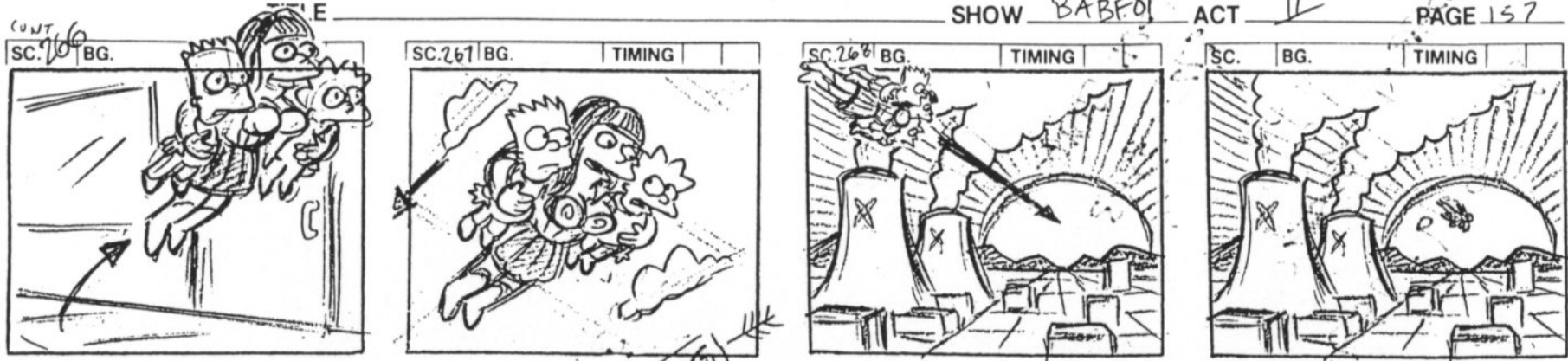

ACTION	<p>① THEY FLY OFF SCREEN and flies away.</p>	<p>② PAN BGT</p>	<p>③ THEY FLY INTO FRAME & INTO 'SUNSET</p>	<p>As they zoom toward the horizon...</p>
TRANS.				
DIAL		<p>LISA Wait a minute, Xena can't fly.</p> <p>LUCY LAWLESS I told you. I'm not Xena. I'm Lucy Lawless.</p>		<p>THE END</p>
TRANS.		<p>LISA Oh.</p>		
NOTES				

THE SIMPSONS

EPISODE #	BABF01
EPISODE TITLE	"I KNOW WHAT YOU DIDDILY-IDDLY-DID"

ACT III

ROUGH DRAFT	4-22-99 <i>REV P.M. 4/23</i>
REVISED	5/13/99
FINAL	6.16.99

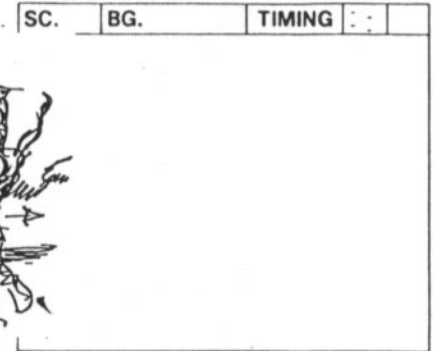
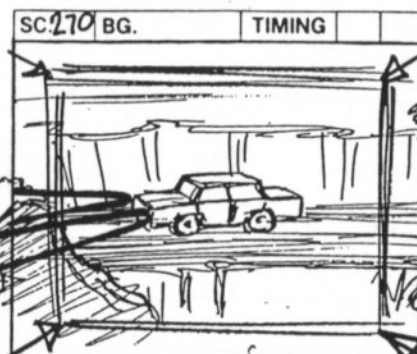
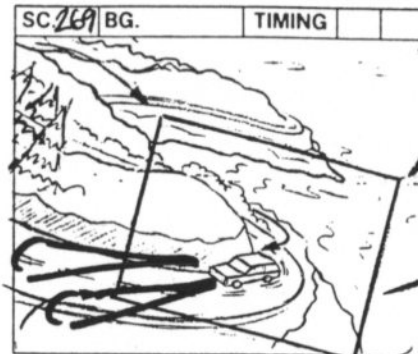
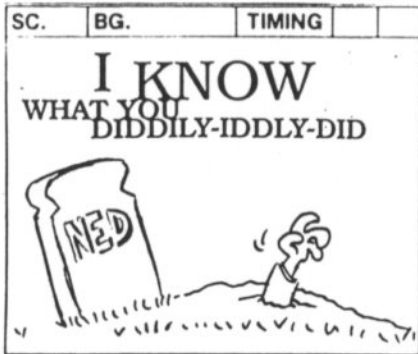

ACTION	TRANS.	DIAL	TRANS.	NOTES
<p>STORYBOARD BY: DAVE BASTIAN GREG LOVELL PETE MICHELS ORLANDO BAEZA MIKE ANDERSON</p>				
<p>FADE IN: EXT. COASTAL ROAD - NIGHT Homer is driving the family home on a dark and foggy night.</p>				

- SLOW DRIFT IN
- PAN BA & FGI ELEMENTS (TREES, ROCKS & FOG)

FOG



FOG

HEADLIGHTS

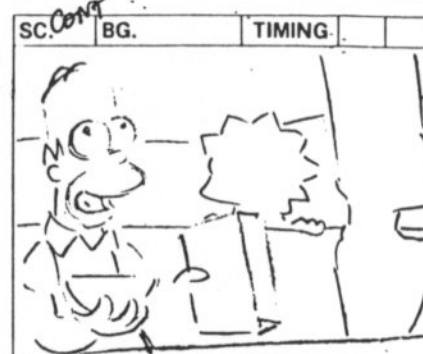
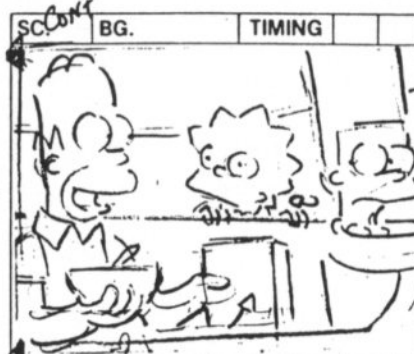
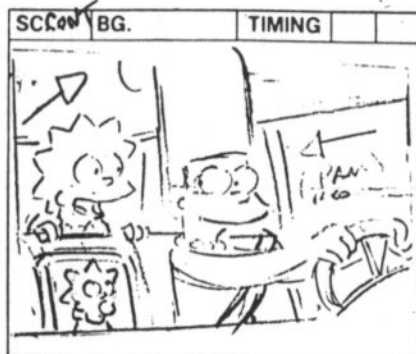
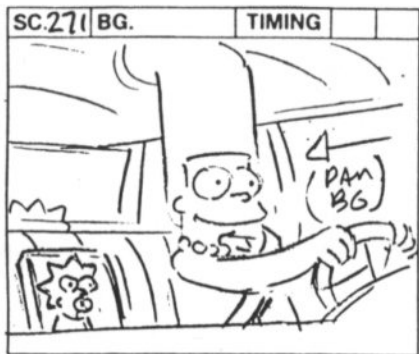

ACTION

Handwritten scribble

(ADJUST LEFT)

He holds up a box and bowl of Sugar Crisp cereal.

TRANS.

DIAL

LISA

That sure was a narrow escape from those horrible mummies.

HOMER

But it was worth it to get back our super Sugar Crisp cereal.

HOMER (CONT'D)

(SINGS, A LA SUGAR BEAR) "Can't get enough of that Sugar Crisp..."

TRANS.

NOTES



ACTION

(squinting)			MARGE pulls over —
-------------	--	--	--------------------

TRANS.

--	--	--	--

DIAL

(M) MARGE (SQUINTING) I'm having a hard time seeing.	(H) HOMER Homer, did you remember to put the fog lights in?	(H) HOMER (TO TUNE OF SUGAR CRISP SONG) "Guess I forgot to put the fog lights in..."	(M) MARGE I better pull over and play it safe.
--	---	--	--

TRANS.

--	--	--	--

NOTES

--	--	--	--

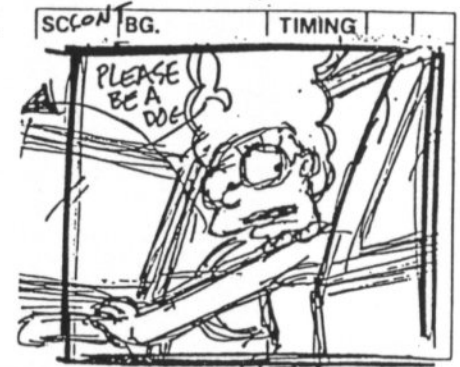
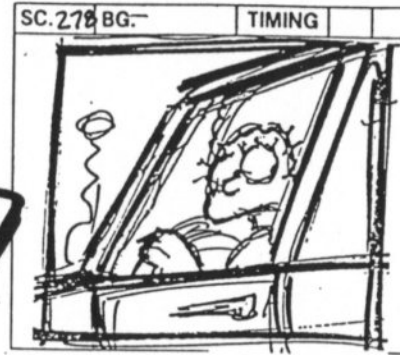
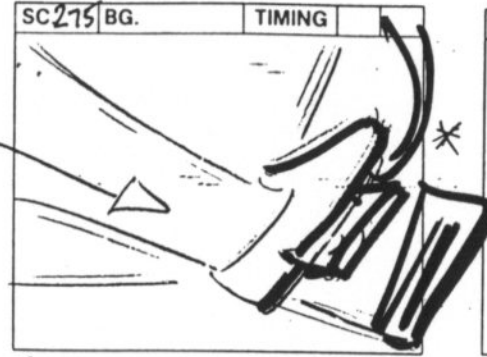

ACTION

(CAMERA JAR)

(MARGE JAMS ON BRAKE)

As Marge pulls over, we hear a loud THUD.

TRANS.

NO
Sc 276, 277

DIAL

MARGE (CONT'D)

(GASP, THEN) Please be a dog.

TRANS.

NOTES

* NEW

* NEW

TITLE _____ SHOW _____ ACT _____ PAGE _____

SC. 27	BG.	TIMING	SC.	BG.	TIMING	SC.	BG.	TIMING	SC.	BG.	TIMING

ACTION

o HOOK UP MARGIE GETTING OUT OF CAR WITH PREVIOUS SCENE

EXT. ROADSIDE - MOMENTS LATER

TRANS.

o THEY ALL TAKE A COUPLE OF STEPS TOWARDS BODY

The Simpsons get out and walk toward a silhouetted body on the side of the road.

DIAL

TRANS.

NOTES

279 CONT

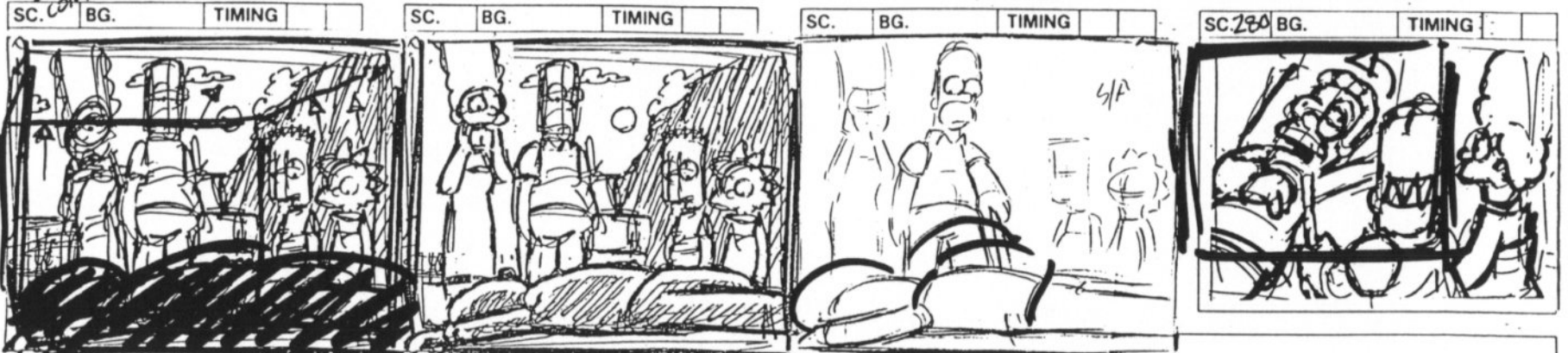

ACTION

PULL OUT, SLIDE NED IN
EXT. ROADSIDE - MOMENTS LATER

The Simpsons get out and find a body face down in front of the car.

Homer rolls the body over as the family looks on. It's NED FLANDERS.

TRANS.

• THEY TAKE TWO STEPS FORWARD

DIAL

MARGE
(GASP) Oh, no!

TRANS.

NOTES

TITLE

SHOW

ACT

SC 281 BG. TIMING

SC 281A BG. TIMING

SC 282 BG. TIMING

SC 283 BG. TIMING

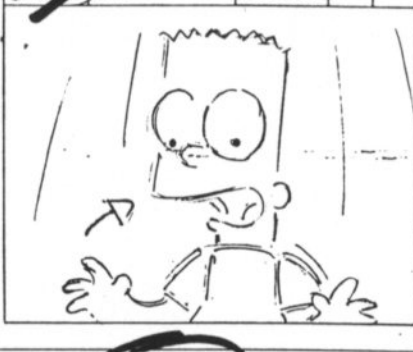

ACTION

TRANS.

DIAL

TRANS.

NOTES

OUT

281

Homer POKES the stick into Ned's eye,
then backs away.

967
960

BART
Ned Flanders!

HOMER
He's dead!

* New

383 8324

ACTION

TRANS.

DIAL

TRANS.

NOTES



Homer JABS Ned some more with the stick.

Homer POKES him again.
 HOMER (CONT'D)
 (SCARED) He's definitely dead!



MARGE
 Oh my God, we killed Ned Flanders!

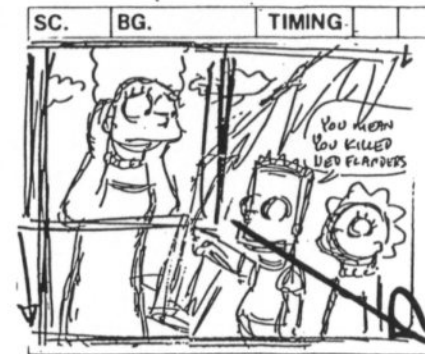

BART
 You mean you killed Ned Flanders.

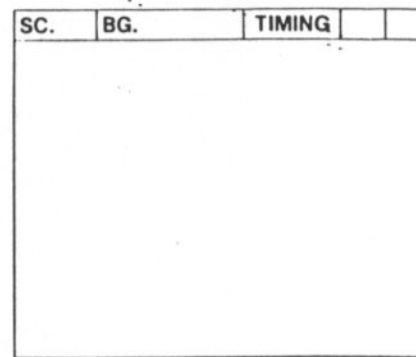
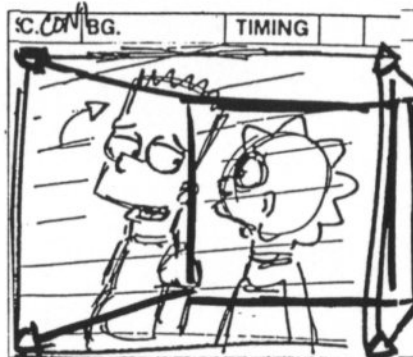
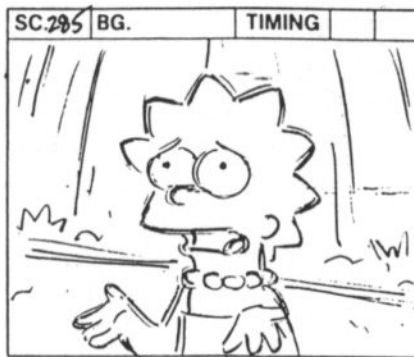
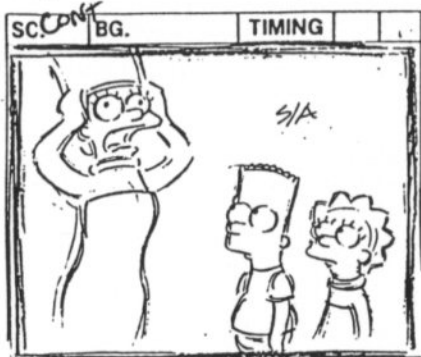

ACTION

TRANS.

DIAL

TRANS.

NOTES

		(WIDEN)	
	MARGE	LISA	BART
	Oh, it was an accident! An accident!	We've got to go to the police.	They'll never believe a Simpson killed a Flanders by accident.
		NEW FIELD (NEW FIELD)	

TITLE _____ SHOW _____ ACT _____ PAGE 1

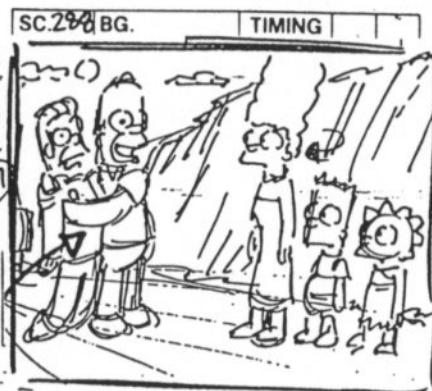
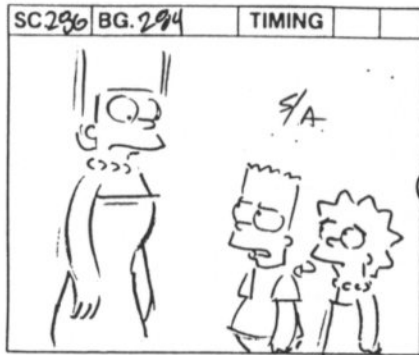

ACTION

ANGLE ON
Homer holding Ned's body upright.

He huddles with Ned's body, sitcom style. Homer WHISPERS and makes Ned's head nod in agreement.

TRANS.

DIAL

12
(LOOKING AT MARGE)
Even I have my doubts.

11
HOMER
(SERIOUSLY) Don't worry.

14
I've got a plan.

15
Okay, the first thing we have to do is... — 15

TRANS.

NOTES

* New

NO SC 287, or 289

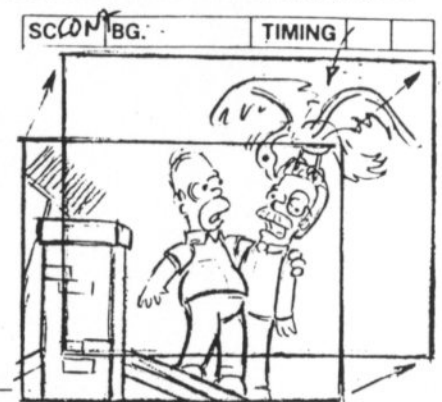
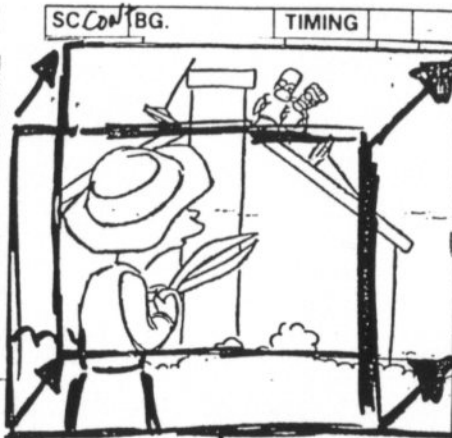

ACTION

adjust up + over

TRANS.

EXT. SIMPSONS HOUSE - THE NEXT DAY
 MAUDE FLANDERS is PRUNING bushes in her front yard. Homer stands on his roof with Ned. There is chimney sweeping equipment next to them.

A BUZZARD swoops onto Ned's head and starts pecking at him.

SHOULDER

DIAL

HOMER
 (SHOUTING) Hey Maude!

Look who's helping me clean the chimney.

TRANS.

NOTES

NO SC 291, 292

NED GLASSES STRAIGHT

TITLE _____

SHOW BABE 01

ACT III

174

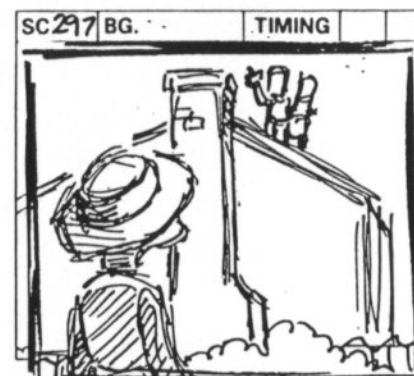
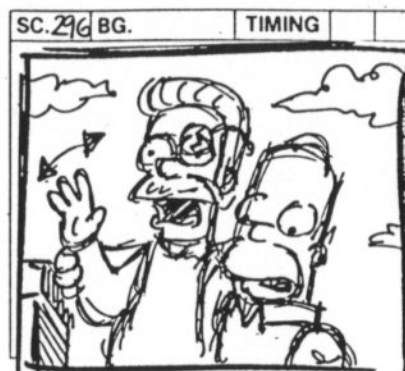

ACTION	Homer shoos the buzzard off.		Homer makes Ned wave, like a puppet.	
TRANS.				
DIAL		<p>MAUDE</p> <p>(SQUINTING) Neddy? Where have you been?</p>	<p>HOMER</p> <p>(AS FLANDERS) Hi, Maude. Diddily.</p>	<p>I've been having fun with my pal Homer.</p> <p>(BEAT) Diddily.</p>
TRANS.				
NOTES				

FILM ROMAN

THE SIMPSONS

TITLE _____

SHOW BABFOI

ACT III

175

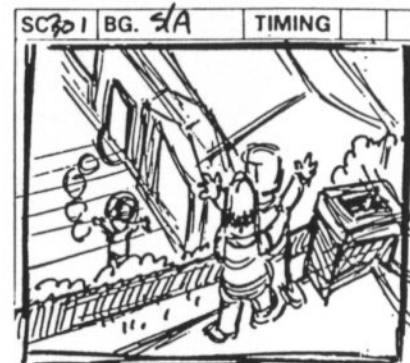
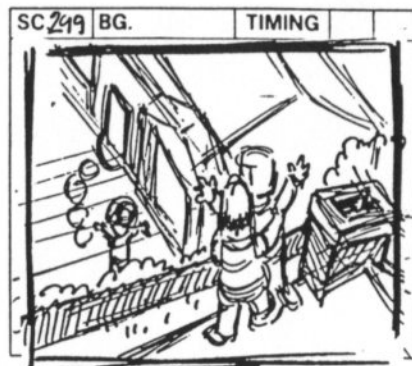

ACTION

ANGLE ON MAUDE
entering her house.
Homer THROWS Ned's body off the roof.

TRANS.

DIAL

MAUDE
Oh, I'm so relieved.

Whenever you go
on one of your late night fog walks, I
get so worried.

HOMER
(AS FLANDERS) Relax, I'm fine. But
when I do die, I don't want any
autopsies.

MAUDE
Well, come on down, you goofy roofy.

TRANS.

NOTES

TITLE _____

SHOW _____

ACT _____

PAGE 176

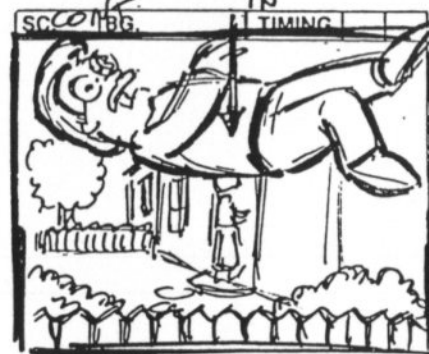
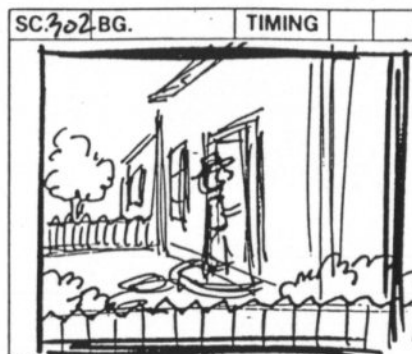
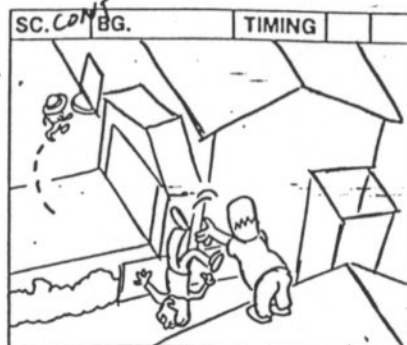
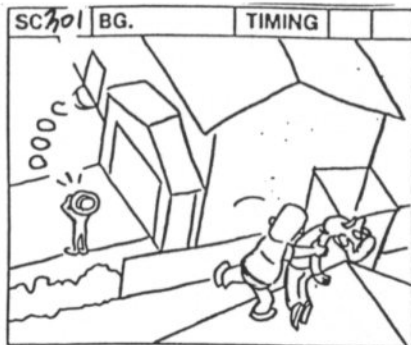

ACTION

TRANS.

DIAL

TRANS.

NOTES

			Maude doesn't see the body fall.
	HOMER (AS FLANDERS) Wow, it sure is slippery up here.		
	MAUDE (TURNS TO HOUSE) Rod! Todd! Daddy's home!	HOMER There you go...	
	SWITCHED LINES FROM ORIGINAL		

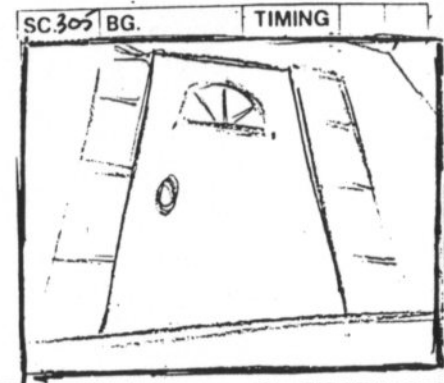
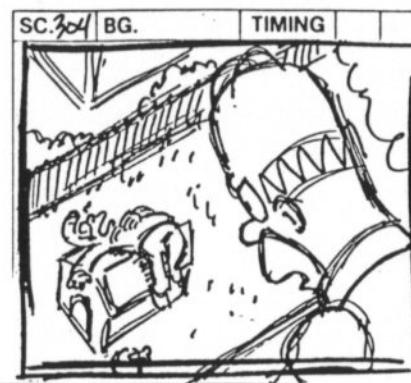
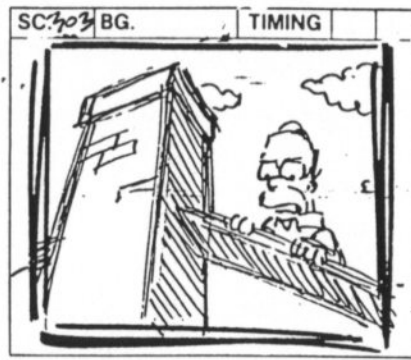
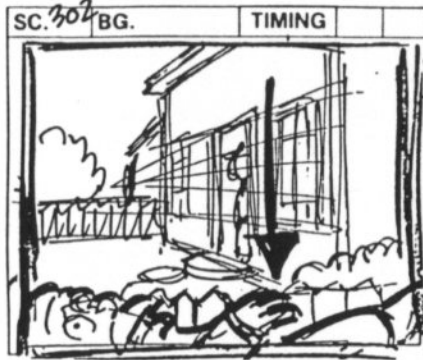

ACTION

MAUDE ENTERS HOUSE

ANGLE ON HOMER
Looking down at Ned's sprawled
backwards on the top of the
doghouse.

EXT. FLANDERS' HOUSE - FRONT DOOR - LATER
Homer has Ned over his shoulder. He
KICKS the door open.

TRANS.

DIAL

HOMER
(FRUSTRATED) Aww,



stupid Flanders.

TRANS.

NOTES

CONT 305

TITLE _____

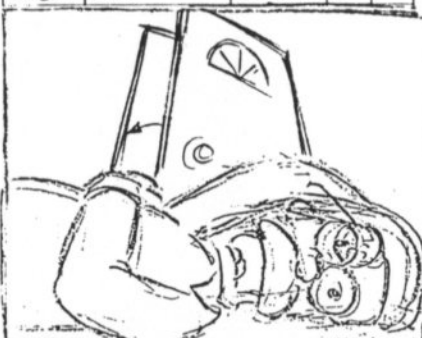
	SC CONT BG.	TIMING	SC CONT BG.	TIMING	SC CONT BG.	TIMING	SC CONT BG.	TIMING
ACTION								
TRANS.								
DIAL			HOMER (AS FLANDERS) Hey Maude, I'm home. (STAGEY) Uh-oh. I think I'm having a heart attack.					
TRANS.								
NOTES					He THROWS Ned in the door		• CLOSING DOOR BEHIND HIM	
					ADJUST TONI WITH NED			

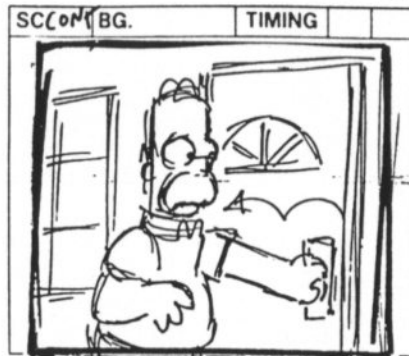
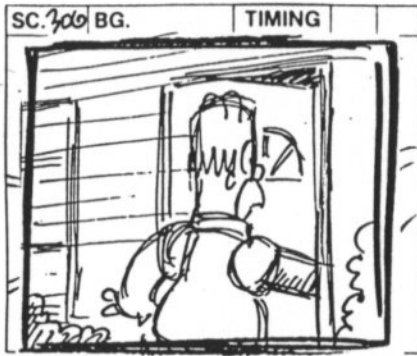

ACTION			
TRANS.		and SLAMS it behind him.	
DIAL			
TRANS.		HOMER REACTS TO SCREAM	He walks off happily.
NOTES		MAUDE (O.S.) (SCREAM)	HOMER (DUSTING HANDS) And that's the end of that chapter.

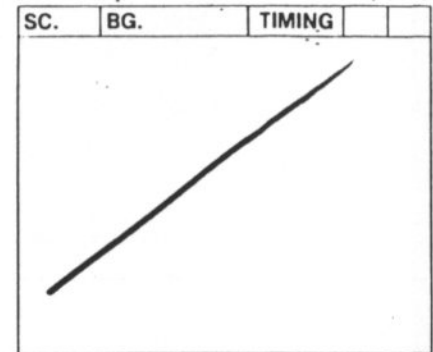
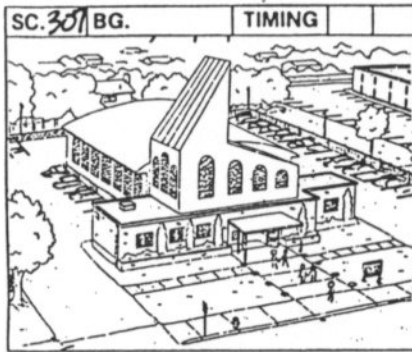

ACTION

EXT. CHURCH - THE NEXT DAY
 SOBBING TOWNSPEOPLE dressed in black filter into the church. The Simpsons walk up the steps.

TRANS.

DIAL

TRANS.

NOTES

	SC. 30A	BG.	TIMING	SC. 30A	BG.	TIMING	SC. 312	BG.	TIMING	SC. 314	BG.	TIMING
ACT												
TRANS.	INT. CHURCH - CONTINUOUS The Simpsons enter with huge inappropriate grins.			WALKS AFTER DIAL			INT. CHURCH - A SHORT WHILE LATER					
DIAL				HOMER (TO FAMILY, LOUD WHISPER) Try not to look too sad -- it'll seem suspicious			REV. LOVEJOY ... And now Ned's best friend will say a few words.			Cont. Homer?		
TRANS.												
NOTES				NO SC 310, 311						NO SC 313		

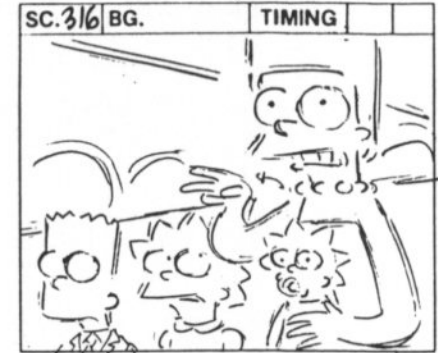
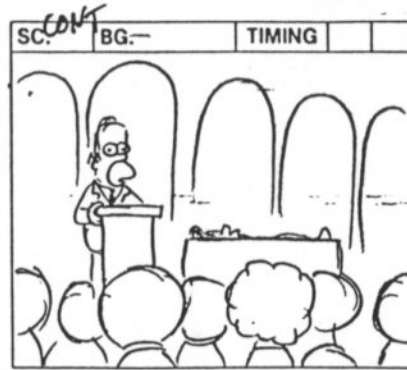
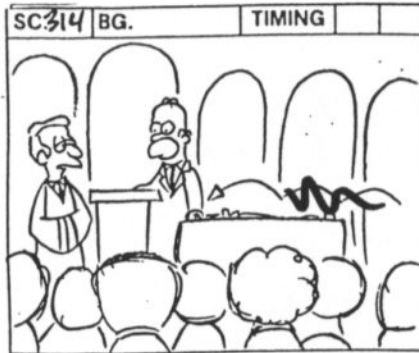

ACTION	then CLEARS his throat and steps to the front of the church.		We see a nervous Marge frantically making the "ixnay" gesture with her hands.
TRANS.			
DIAL		HOMER When I think about Ned,	I can't help but remember the look on his face when Marge drove over... (M) "IXNAY")
TRANS.			
NOTES			New

TITLE _____

SHOW _____

ACT _____

PAGE 183

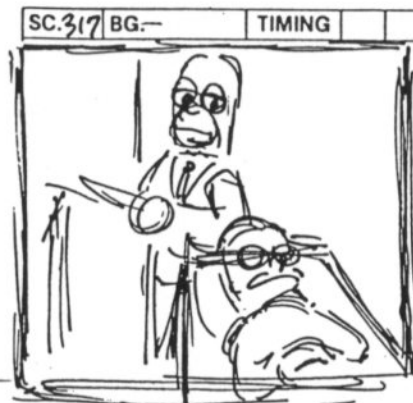

ACTION

(Homer covers Mike)

TRANS.

DIAL

Homer

Oh, wait...

TRANS.

NOTES

What
I'd like to say we're still looking for
the real killers. Anyway, in
conclusion, a man cannot be forced to
testify against his wife. (WINKS AT
MARGE)

(TO NED) We'll miss you, buddy.

ADJUST w/HOMER

He punches Ned affectionately
on the shoulder.

TITLE _____

SHOW _____

ACT _____

PAGE 184

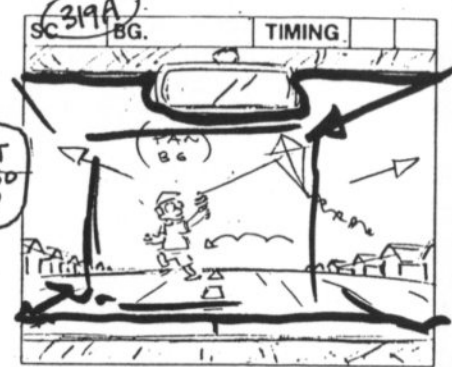
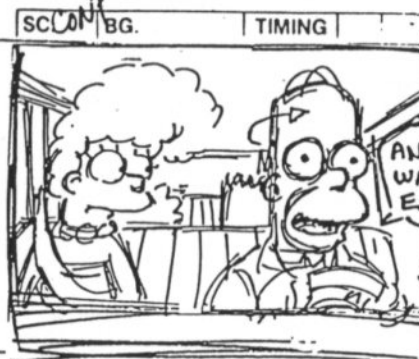
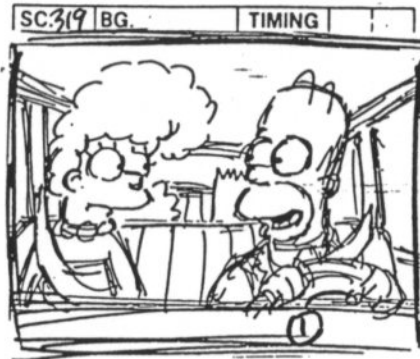
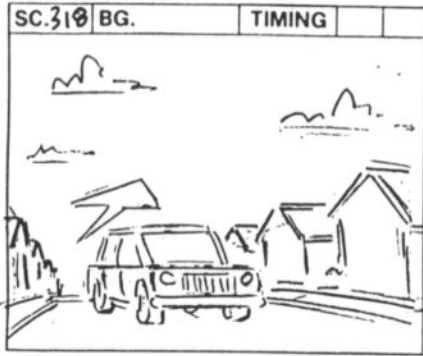

ACTION



The Simpsons are driving down their street.

Through the window, he sees Milhouse, who is happily flying a kite.

TRANS.

31-PACK

DIAL

HOMER

Hey, we just got away with murder.

And it was so easy.

(EXCITED)

TRANS.

NOTES

* New

TITLE _____

SHOW _____

ACT _____

319B

SC. ~~318~~ BG. 5/A 319 TIMING



SC. ~~318~~ BG. TIMING

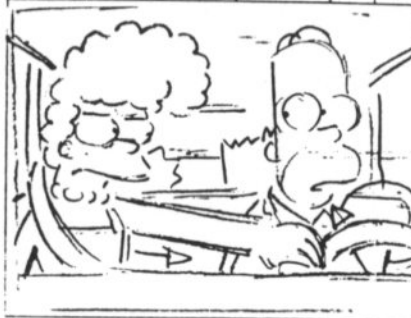

319C

SC. BG. TIMING

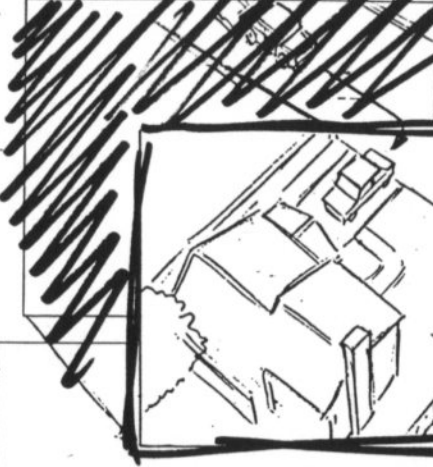

SC. BG. TIMING

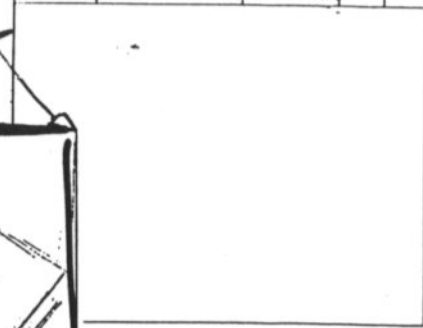

ACTION

ADJUST PAN WIENER. BG.

MARGE turns wheel back

H starts to turn the wheel in Milhouse's direction, but Marge turns it back.

TRANS.

EXT. SIMPSON HOME - LATER THAT DAY
The Simpsons pull into their driveway.

DIAL

HOMER (CONT'D)
You know, I've never liked that little wiener Milhouse.

TRANS.

NOTES

(WAS 318)

319D

 SC. ~~319~~ BG. TIMING

SC. 320 BG. TIMING



SC. 321 BG. TIMING



SC. 322 BG. TIMING



ACTION		and get out of the car.		
TRANS.				
DIAL	MARGE (FIRMLY) No more murders.	HOMER But you got to kill...	MARGE No.	
TRANS.				
NOTES				

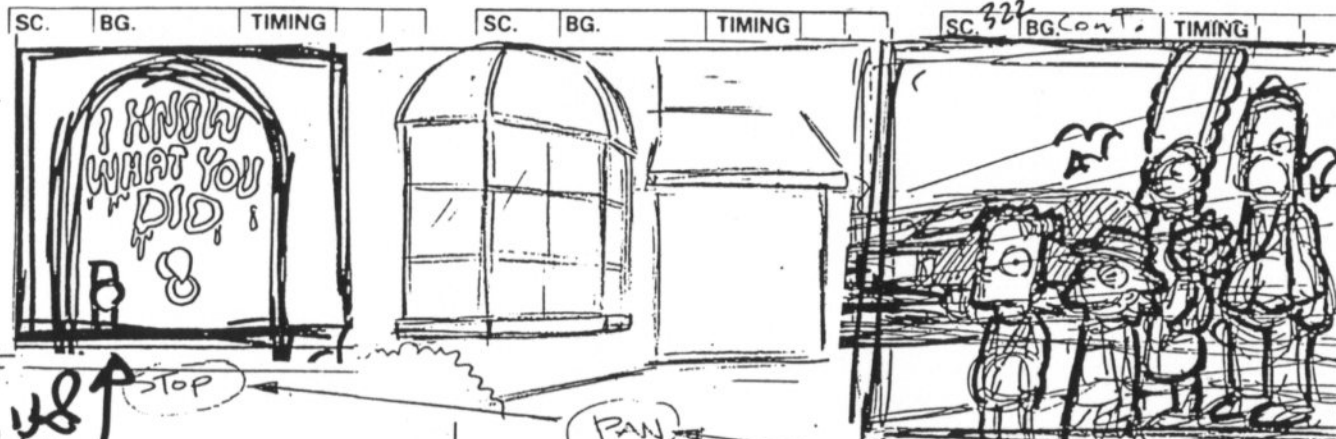

ACTION

K188 ↑ STOP

↓ PAN

The family walks up to the front door. Written in red letters on the door is, "I KNOW WHAT YOU DID".

START

- SIMPSONS TAKE TWO STEPS, TURN, MARGIE GASPS
- ZIP TO DOOR

TRANS.

DIAL

MARGE (CONT'D)
(GASP) Someone saw us.

(GASP)

TRANS.

NOTES

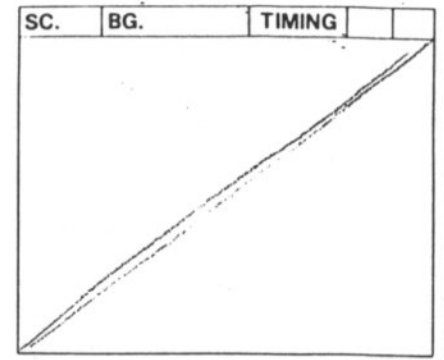
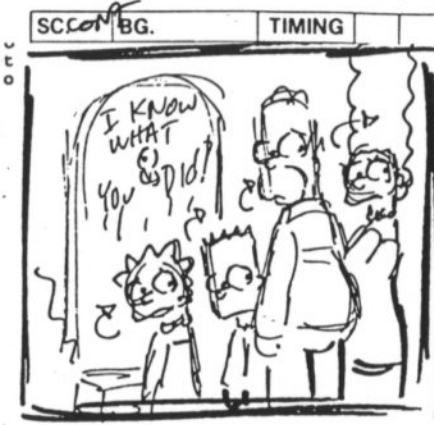
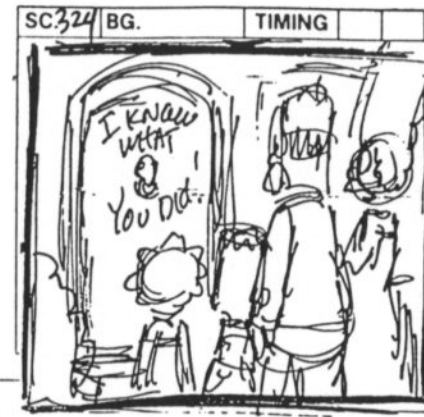
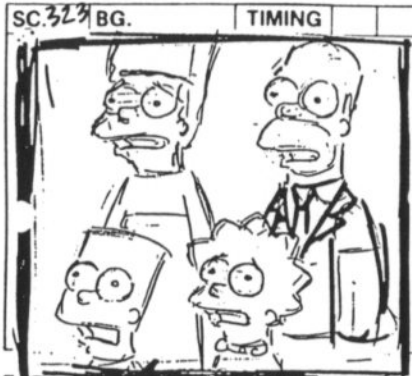

ACTION

TRANS.

DIAL

HOMER/LISA/BART
But who?

TRANS.

NOTES

TITLE _____

SHOW _____

ACT _____

PAGE 188A



ACTION

(START)

(PAN)

(STOP)

FAMILY'S POV

We do a SLOW-MOTION PAN PAST various Springfieldites on the sidewalk staring suspiciously at them: Chief Wiggum (standing on the sidewalk, TAPPING his billy club in his palm), Krusty (slowly PUFFING a cigar), Moe (wearing his apron and slowly CLEANING a beer mug), Sherri and Terri (slowly TWIRLING a jumprope with no one in the middle), and finally Homer, who points accusingly at Marge.

TRANS.

VERY SLOW

DIAL

TRANS.

NOTES

FILE ROMAN

THE SIMPSONS

TITLE _____

SHOW _____

ACT _____

PAGE 189

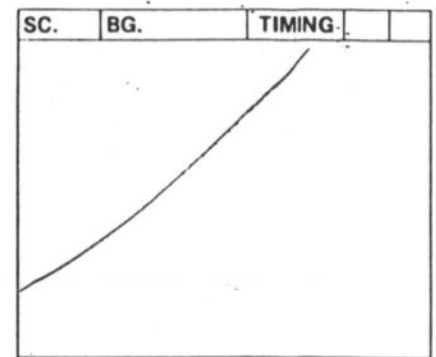
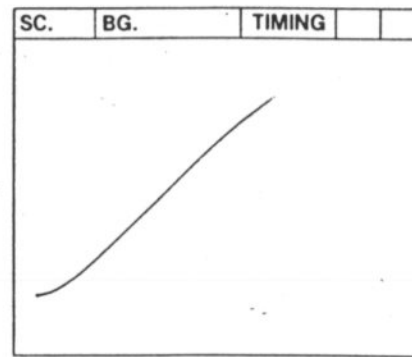
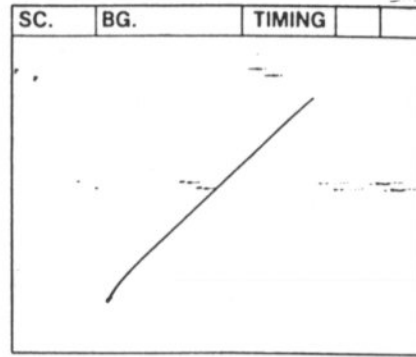
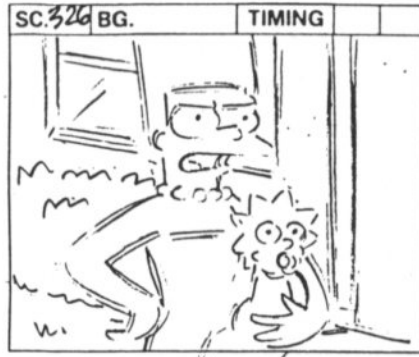

ACTION

TRANS.

DIAL

TRANS.

NOTES

MARGE
Homer! Stop that!

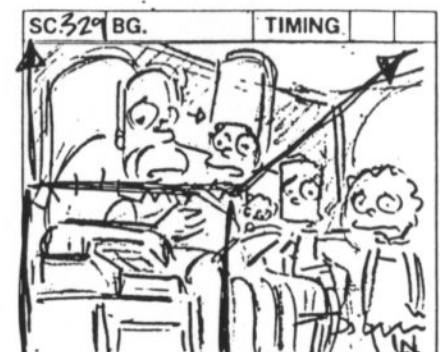
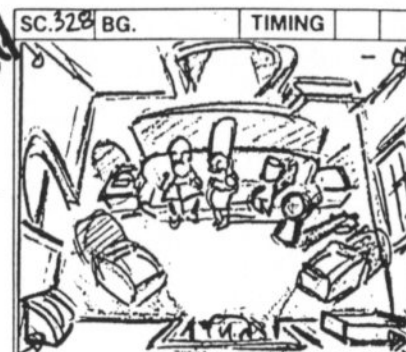
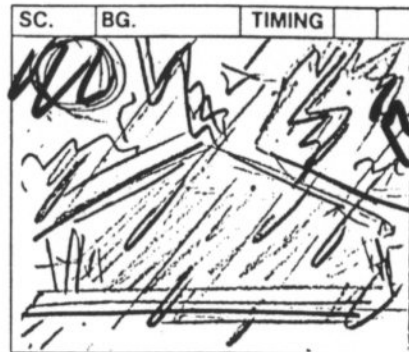
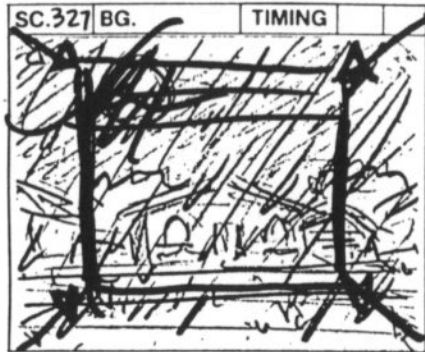

ACTION

EXT. SIMPSON HOUSE - NIGHT -
ESTABLISHING

A THUNDER STORM is going on.

We see a flash of lightning.

INT. SIMPSON HOUSE - LIVING ROOM -
CONTINUOUS

The phone is RINGING in the
darkened house.

TRUCK OUT
FROM PHONE

TRANS.

DIAL

TRANS.

NOTES

SHADOWY

HOM.
NOT
READING

MARGE
(NERVOUSLY) Who could be calling at
this hour?

Sc 327 - 382 IS ALL NEW AS OF 6/16/99 !! →

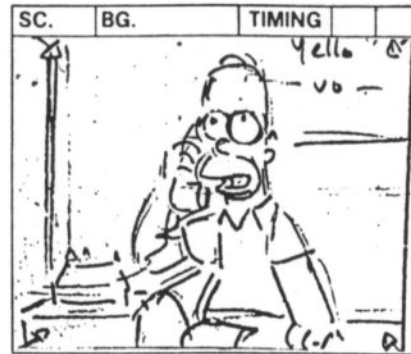
ACTION

Homer nervously answers it.

TRANS.
DIAL

HOMER
(TERRIFIED SOUNDS, THEN CALM)
Y'ello?

HOMER
(FRIGHTENED SOUND) Who is this?

HOMER
No, it's Homer.

TRANS.

CREEPY VOICE
I know you're alone.

CREEPY VOICE
Is this Maude Flanders?

CREEPY VOICE
(NORMAL MOE VOICE) Oh, hey Homer, it's
Moe. I must have dialed the wrong
number.

NOTES

TITLE _____

SHOW _____

ACT _____

PAGE _____

FLASH CUT
⚡

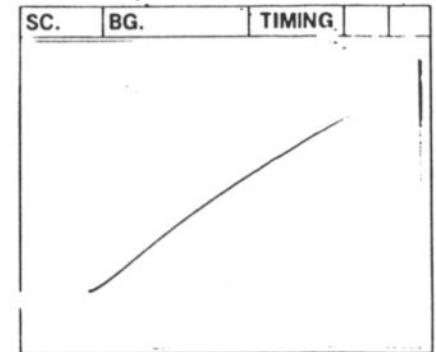
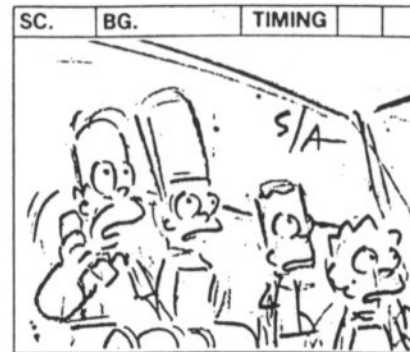

ACTION

Suddenly, THUNDER ROLLS and LIGHTNING FLASHES illuminating the house. We see the words "I KNOW WHAT YOU DID" and "TONIGHT'S THE NIGHT" written in red all over the walls.

TRANS.

DIAL

TRANS.

NOTES

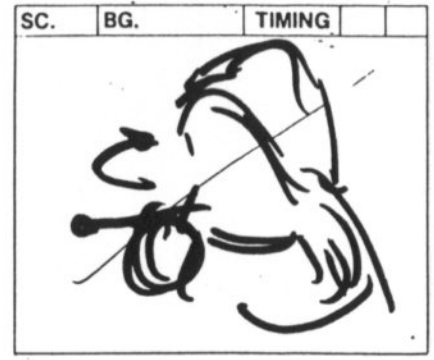
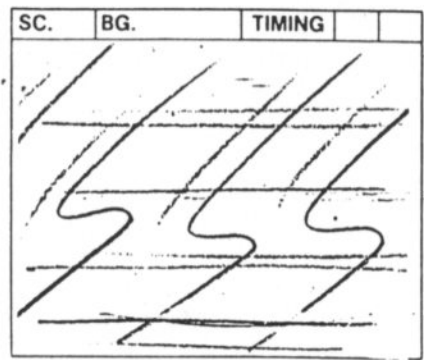

ACTION	(STREET → ZIP PIN →)		
	There is a second FLASH OF LIGHTNING,		revealing a silhouetted figure in a rain slicker and hat, in the middle of writing "I KNOW WHAT YOU DID" on one of the walls.
TRANS.			
DIAL	SIMPSONS (TERRIFIED SCREAMS)		
TRANS.			
NOTES			

TITLE _____

SHOW _____

ACT _____

PAGE 194

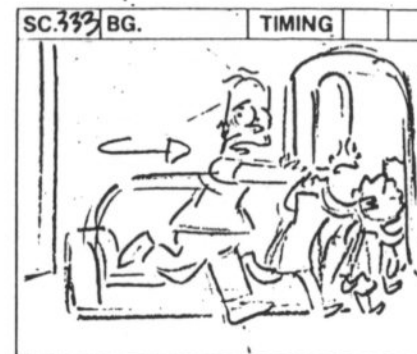
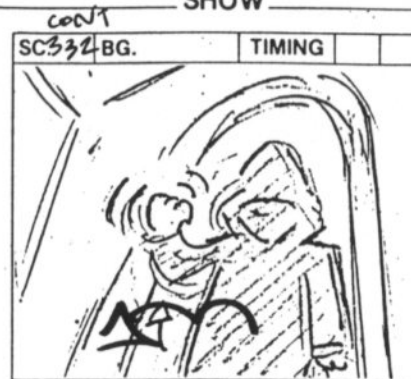
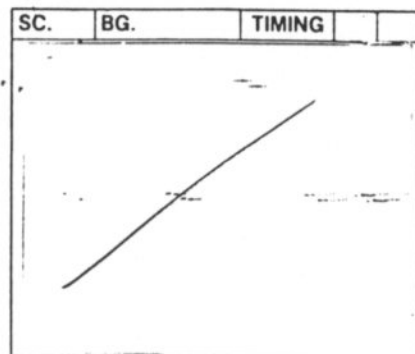
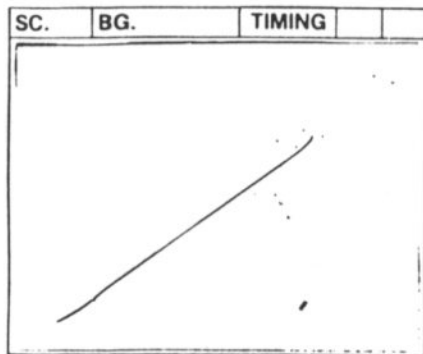

ACTION

He turns toward the Simpsons and shakes his fist.

The family runs out the front door.

TRANS.

DIAL

TRANS.

NOTES

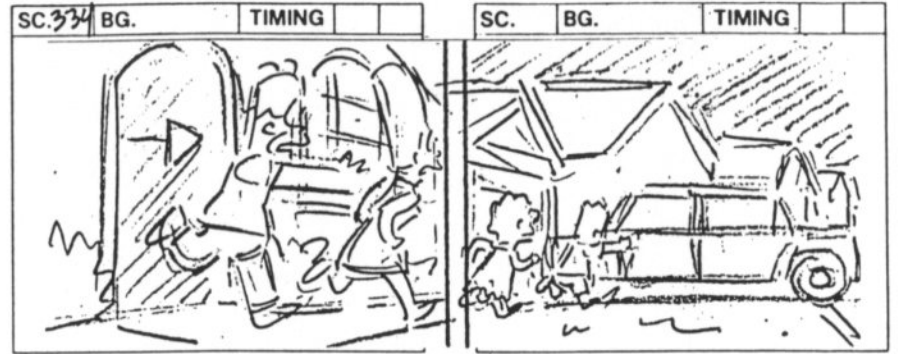
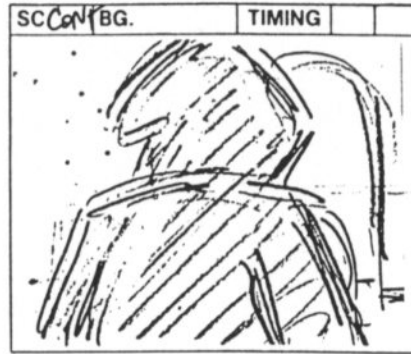
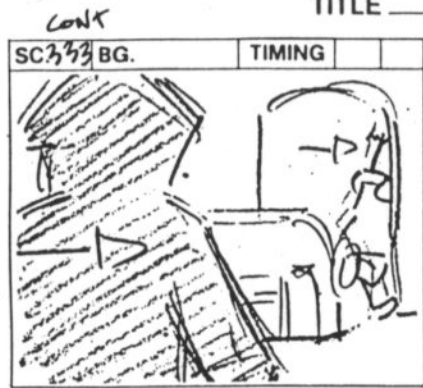

ACTION

TRANS.

DIAL

TRANS.

NOTES

EXT. SIMPSON HOUSE - CONTINUOUS
They jump in the car.

TITLE _____

SHOW _____

ACT _____

PAGE _____

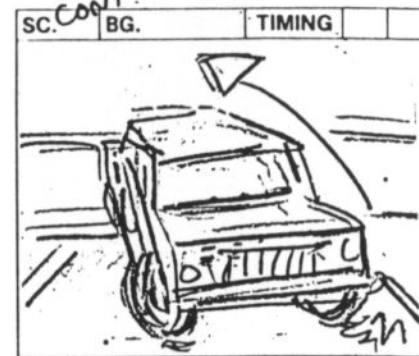
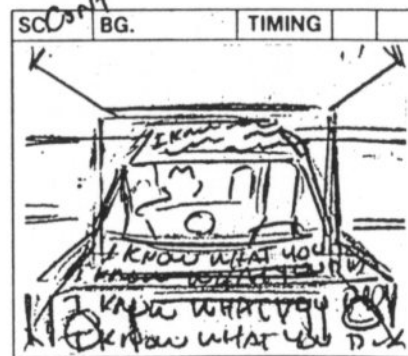
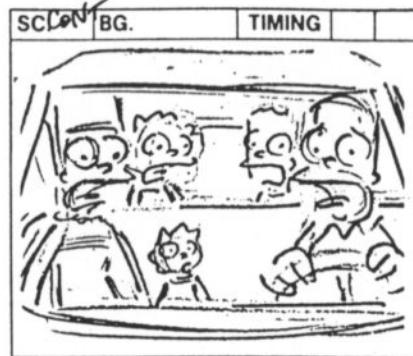
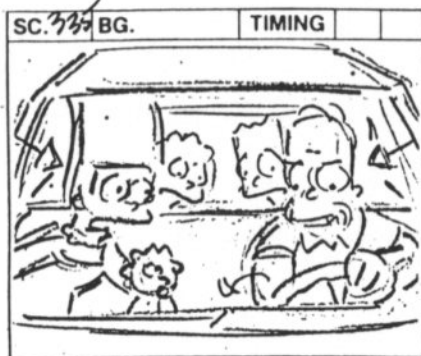

ACTION

Homer FIRES UP the engine.

Lightning FLASHES.

(QUICK CUT OUT)

We see the words "I KNOW WHAT YOU DID" have been painted all over the exterior of the car.

TRANS.

INT. SIMPSON CAR - CONTINUOUS

They see the writing on the hood of the car.

DIAL

SIMPSONS

(SCREAM)

TRANS.

NOTES

TITLE _____

SHOW _____

ACT _____

335
SC. 091 BG. TIMING

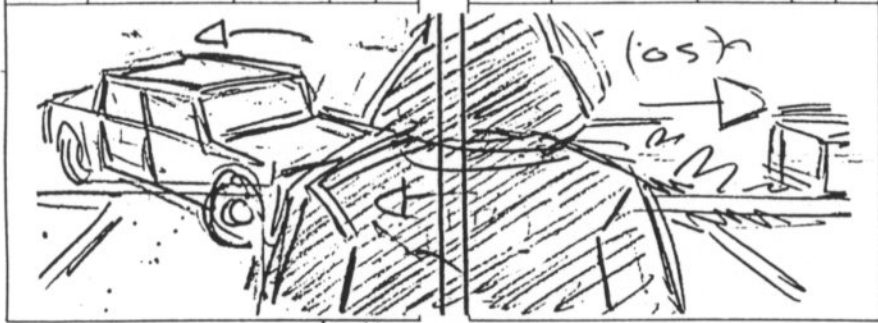

SC. BG. TIMING

334
SC. 234 BG. TIMING



SC. BG. TIMING

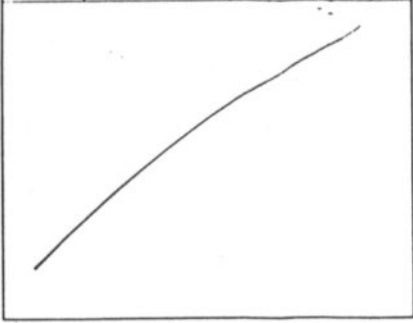

(← INTO SC)

ACTION

Homer floors the gas.	The car SPEEDS away.		

TRANS.

--	--	--	--

DIAL

		<p>HOMER (LOOKING HEAVENWARD, PANICKY) Dear God, it's me again, asking you to get me out of another jam.</p>	
--	--	--	--

TRANS.

--	--	--	--

NOTES

--	--	--	--

TITLE _____

SHOW _____

ACT _____

PAGE _____

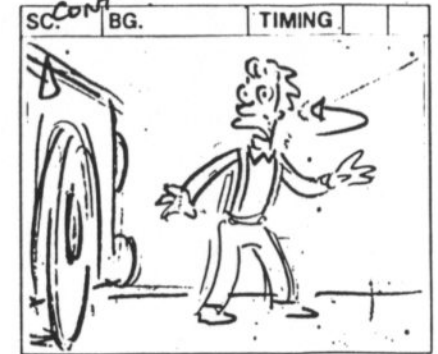
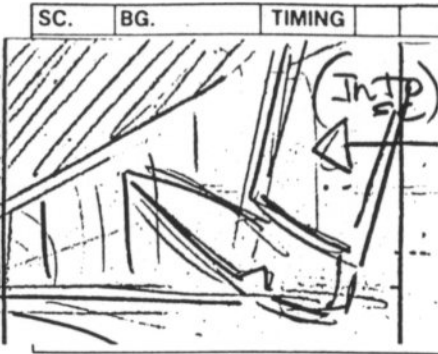
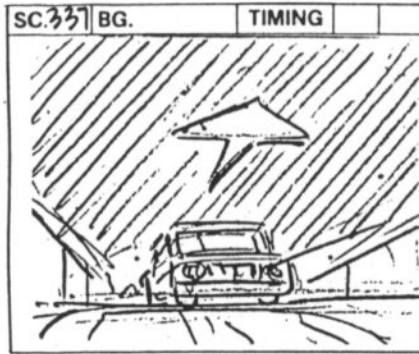

ACTION

TRANS.

DIAL

TRANS.

NOTES

TITLE _____

SHOW _____

ACT _____

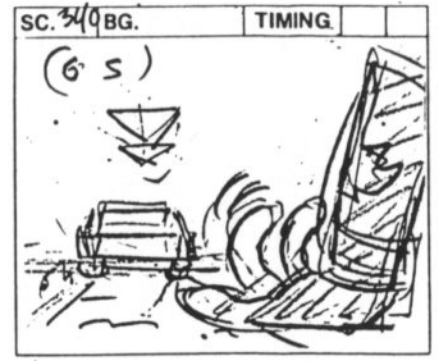
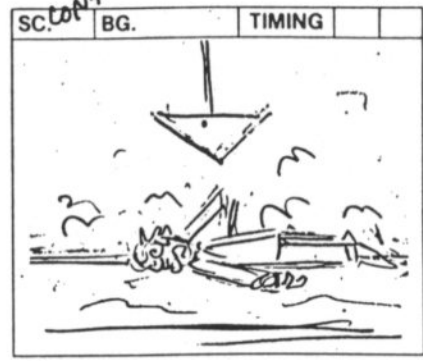
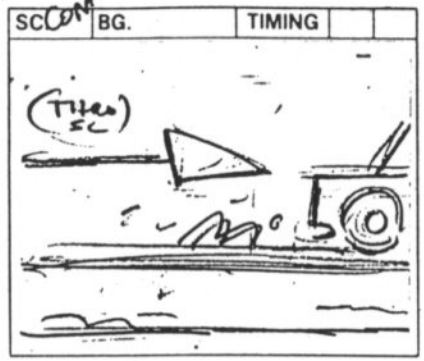
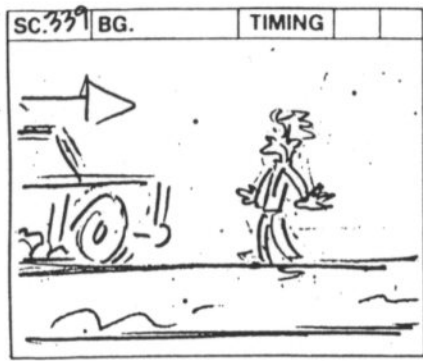

ACTION

The car HITS Lenny,

who goes flying in the air.

TRANS.

DIAL

LENNY
(DOPPLER PAINED SOUND)

TRANS.

NOTES

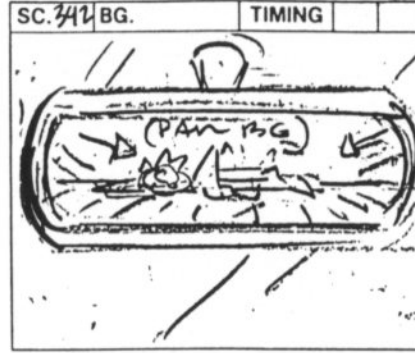
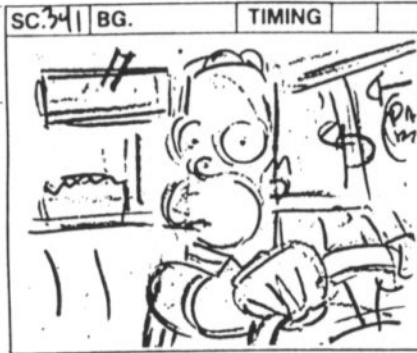

ACTION

TRANS.

DIAL

TRANS.

NOTES

BI-PACK

HOMER
(SHRIEKS,

THEN LOOKS HEAVENWARD AGAIN)
All right, Lord. I don't like you and
you don't like me, but what do you have
against poor Lenny?

CONT 243

TITLE _____

SHOW _____

ACT 3

PAGE 201

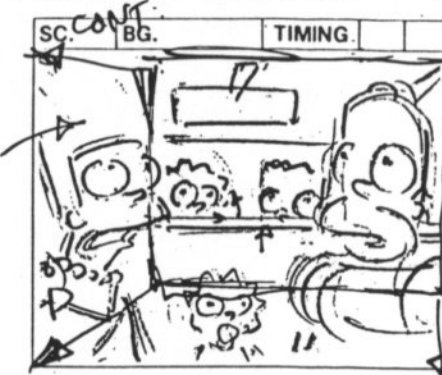
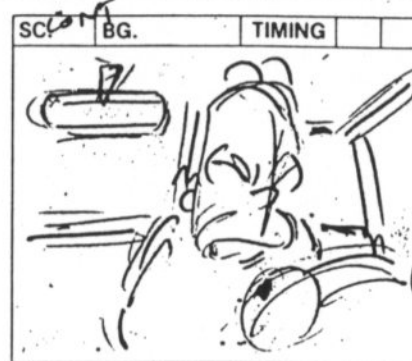
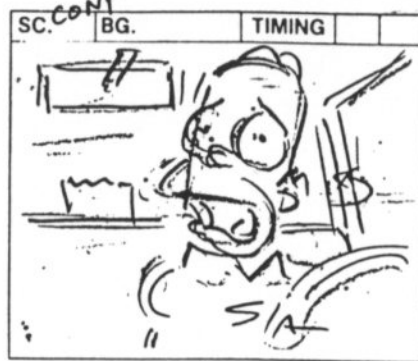
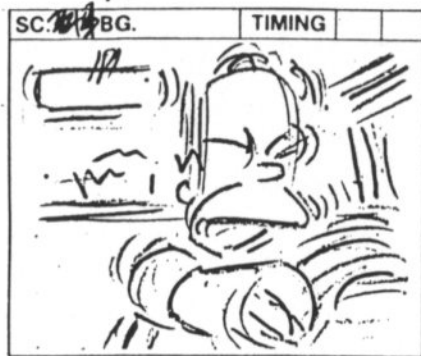

ACTION

We hear another THUD.

We hear two quick THUDS.

QUICK PULL OUT

TRANS.

DIAL

CARL (O.S.)
(STRUCK-BY-CAR SOUND)

HOMER
Or poor Carl?

PATTY/SELMA (O.S.)
(STRUCK-BY-CAR SOUND)

MARGE
Patty and Selma!

TRANS.

NOTES

ONE
CAM
SHAKES

2 CAM
SHAKES

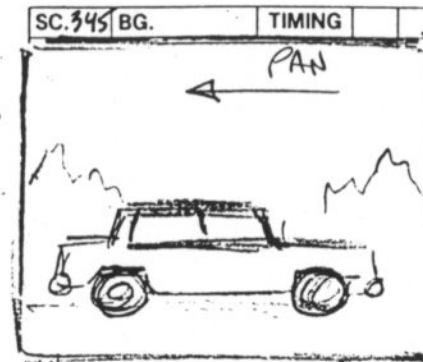
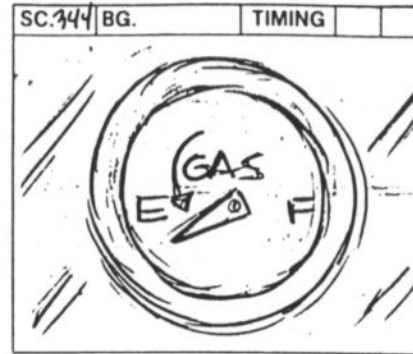
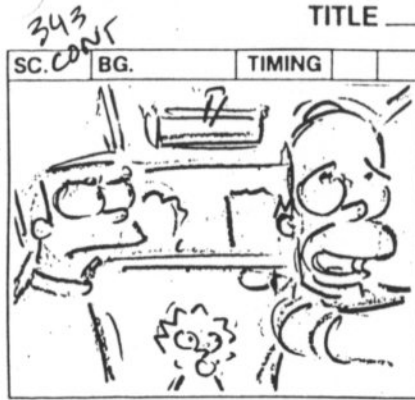

ACTION

TRANS.

DIAL

TRANS.

NOTES

	<p>ANGLE ON</p> <p>The gas gauge. We see the needle go below "E".</p>	<p>E.G. slows to A STOP</p>	
		<p>The car SPUTTERS and stops.</p>	
		<p>CLOUDS STOP MOVING</p>	
	<p>HOMER</p> <p>(LOOKING HEAVENWARD, TOUCHED) You remembered.</p>		

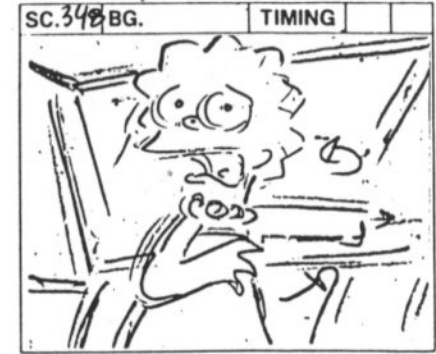
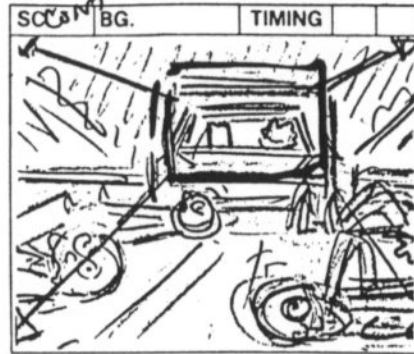
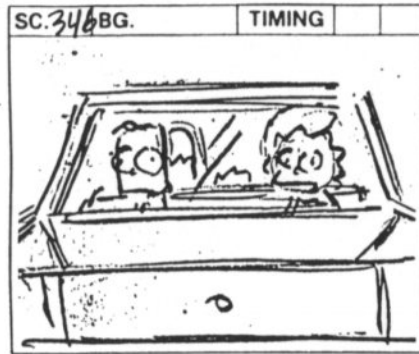
ACTION
ANGLE ON

Bart and Lisa looking out the back window

at the bodies in the road. They're still moving enough for us to know they're not dead.

TRANS.
DIAL
BART

 Maybe you should let Mom drive, Dad. ...
 You didn't kill any of 'em.

LISA

He's getting closer!

TRANS.
NOTES

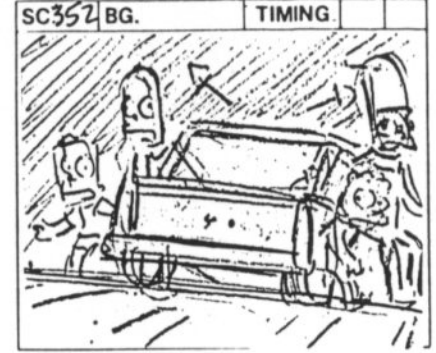
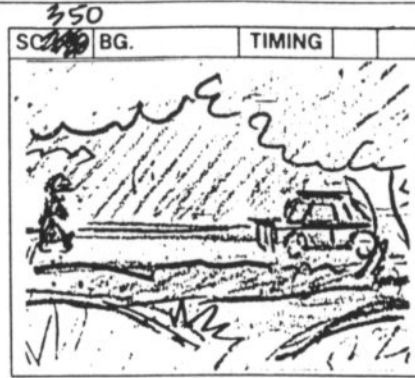
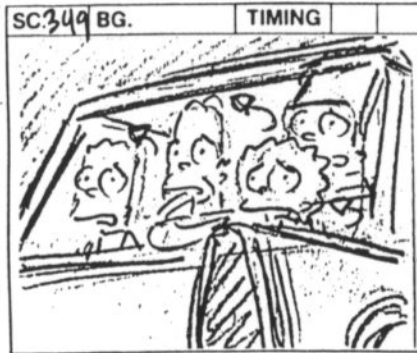

ACTION

In the distance, we see the raincoat guy walking menacingly toward the car.

The family jumps out of the car.

TRANS.

DIAL

TRANS.

NOTES

hook
up

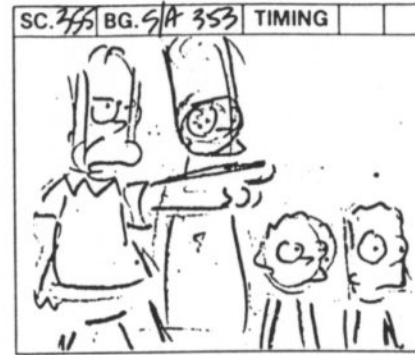
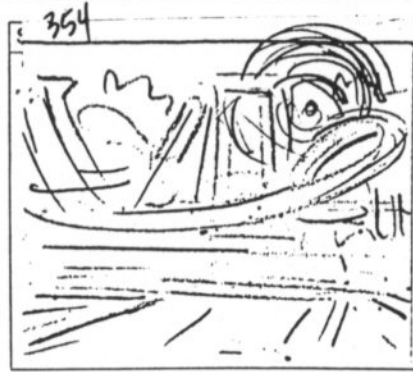
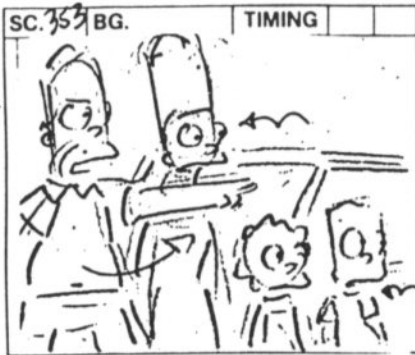

ACTION

He points to a creepy-looking, rundown amusement park.

He points to the pet cemetery.

(SEE DESIGN FROM THOH #3.)

TRANS.

DIAL

HOMER
Okay, Marge, you hide in the abandoned amusement park.

HOMER (CONT'D)
Lisa, the pet cemetery.

TRANS.

NOTES

TITLE _____

SHOW _____

ACT _____

PAGE _____

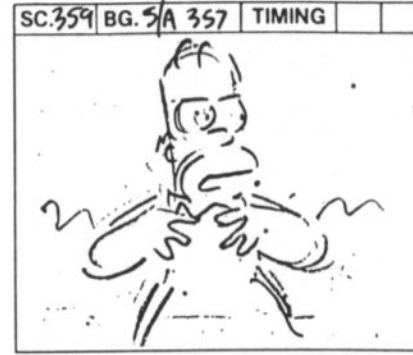
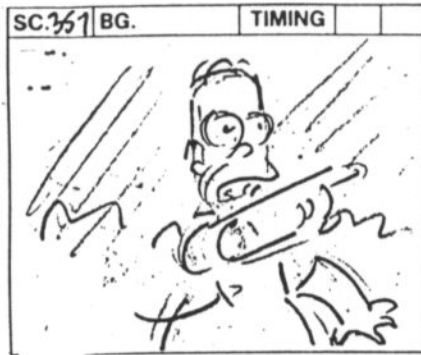

ACTION

He points to the roller disco.

We hear a slightly warped
"BOOGIE OOGIE OOGIE".

He points

TRANS.

DIAL

HOMER (CONT'D)
Bart, spooky roller disco.

HOMER (CONT'D)
And I'll go skinny dipping in that lake,
where the sexy teens were killed a

hundred years ago tonight.

TRANS.

NOTES

TITLE _____

SHOW _____

ACT _____

PAGE _____

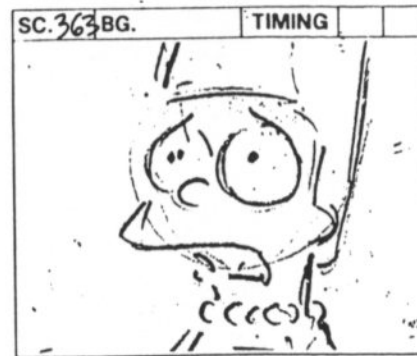
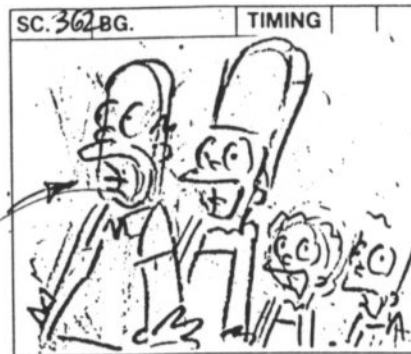
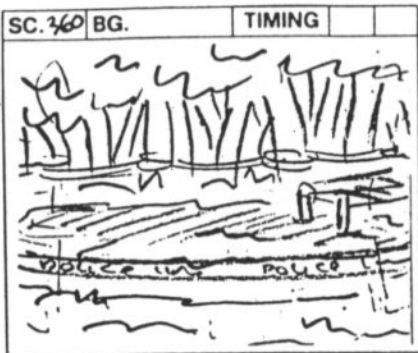

ACTION	to a lake with yellow police tape around it.	The family turns to see Ned, wearing the raincoat and hat.	HOOK UP	
TRANS.				
DIAL		HOMER (CONT'D) Now, Flanders, I want you to...	SIMPSONS (SCREAM)	MARGE It's impossible. I killed you.
TRANS.				
NOTES				

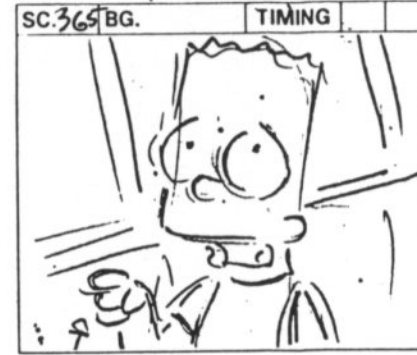
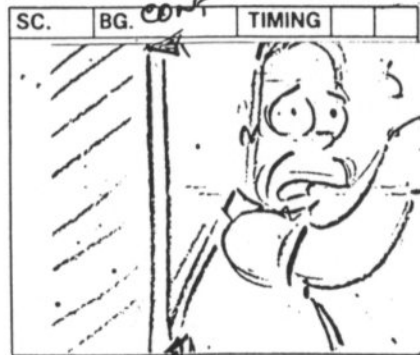

ACTION	<p style="text-align: center;">PAN</p> <p style="text-align: center;">FLOPPED</p> <p style="text-align: center;">A stick enters frame, poking him in the eye.</p>		
TRANS.			
DIAL	<p style="text-align: center;">FLANDERS</p> <p style="text-align: center;">You can't kill the undead, silly.</p>	<p style="text-align: center;">HOMER</p> <p style="text-align: center;">He's undead, all right.</p>	<p style="text-align: center;">BART</p> <p style="text-align: center;">Are you a zombie?</p>
TRANS.			
NOTES			

TITLE _____ SHOW _____

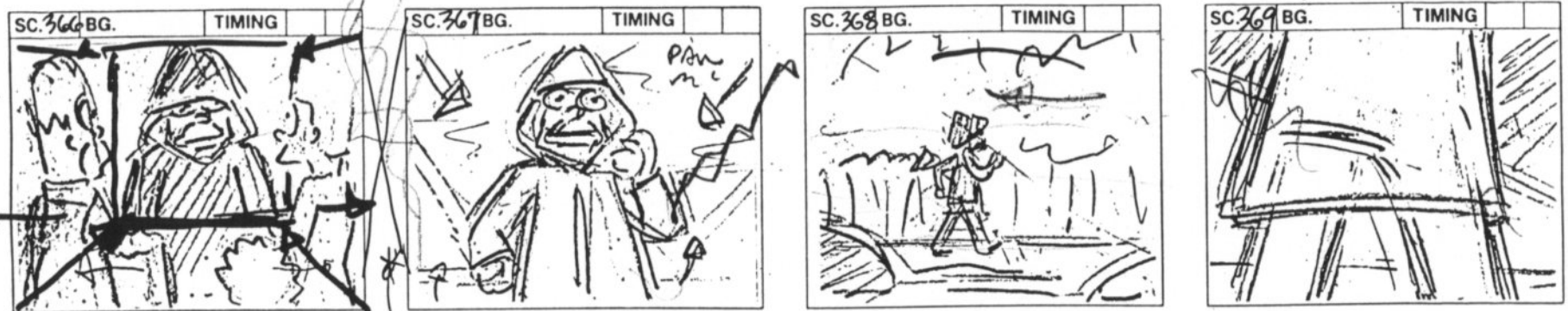

ACTION
TRANS.
DIAL
TRANS.
NOTES

<p>DRIFT IN TO MATCH COMPOSITION OF SC 367</p>	<p><i>X-DISS</i> REG CLOTHES</p> <p>DISSOLVE TO:</p>	<p>We hear an OMINOUS WOLF HOWL.</p>	
<p>← REG FAMILY OUT →</p>	<p>EXT. COASTAL ROAD - NIGHT - FLASHBACK Ned is powerwalking feyly next to the foggy road.</p>	<p>EASE IN TO SPEED UP</p>	
<p>FLANDERS Oh, I wish.</p>	<p>FLANDERS I'm making record time on this fog walk!</p>	<p>FLANDERS (CONT'D) Ooo, better pick up the pace.</p>	
<p>You see, that night you hit me with your car...</p>			
		<p>SPEED UP WALK + PAN AFTER LINE</p>	

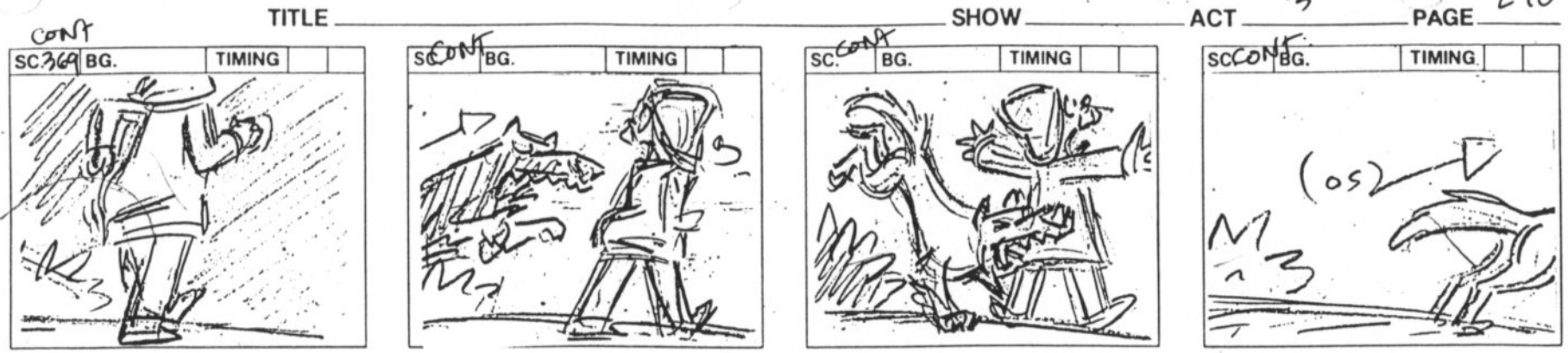

ACTION	He starts walking even faster, his rear wiggling even more.	Suddenly, a large WOLF LEAPS out of the darkness at Ned,	sinking his teeth into his still-wiggling ass.	Ned and the wolf COLLAPSE out of frame.
TRANS.				PAN TO BUSINESSES
DIAL			FLANDERS (CONT'D) (PAINFUL SHRIEKS)	
TRANS.				
NOTES				

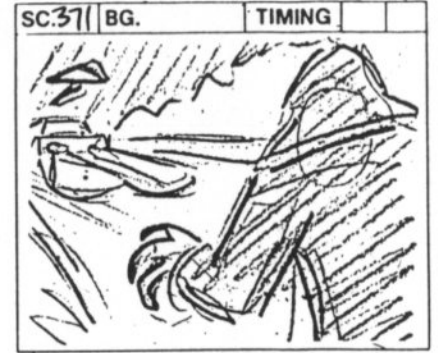
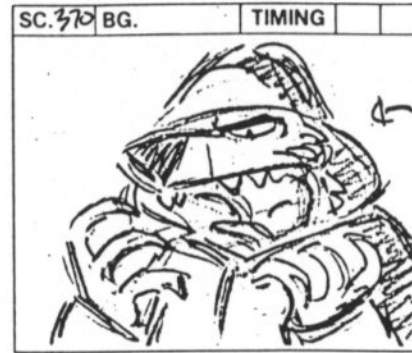
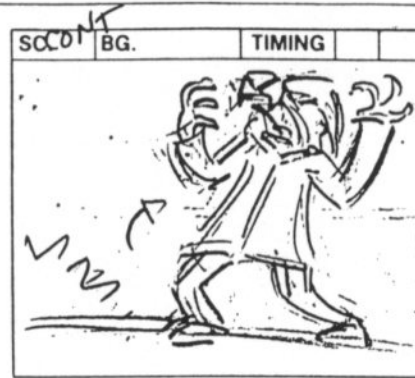
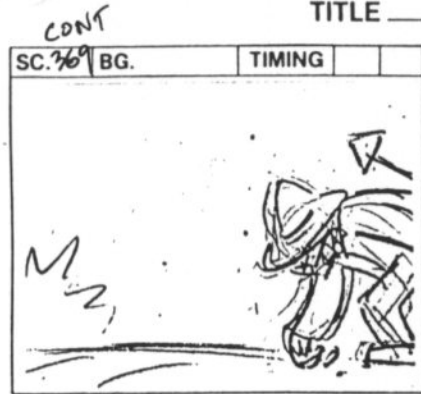

ACTION

After a short beat,

a WEREWOLF NED rises

and bares his fangs.

He spots the headlights of the oncoming Simpson car (with Marge behind the wheel).

TRANS.

DIAL



TRANS.

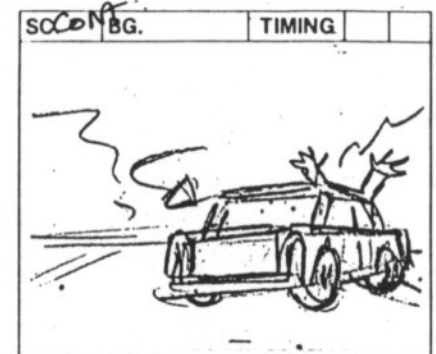
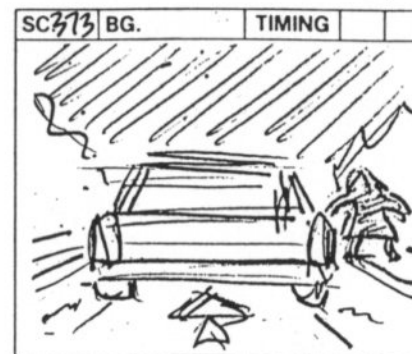

NOTES

ACTION

Werewolf Ned LICKS his chops in anticipation and prepares to pounce.

At the last second,

the Simpson car veers over to the side of the road and HITS him.

TRANS.
DIAL

FLANDERS (CONT'D)
(SHORT WOLF-STRUCK-BY-CAR SOUND)

TRANS.
NOTES

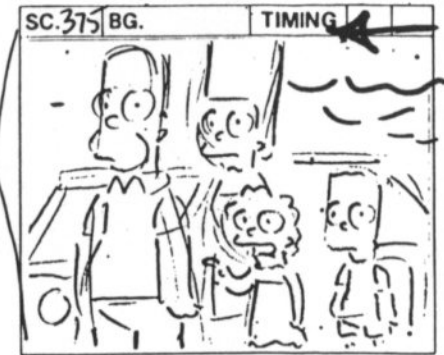
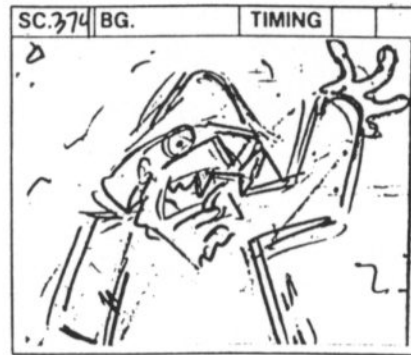
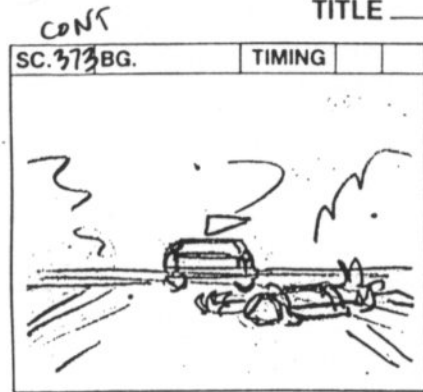

ACTION

Werewolf Ned morphs back to human form.

DISSOLVE
BACK
TO
FAMILY

TRANS.

END OF FLASHBACK

DIAL

LISA

So you were going to kill us.

TRANS.

NOTES

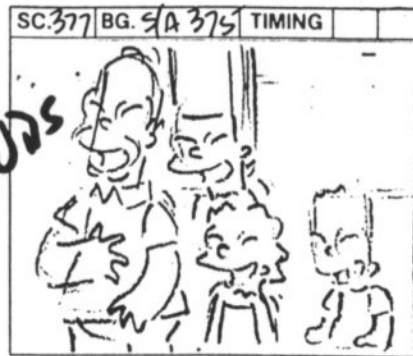

ACTION

TRANS.

DIAL

TRANS.

NOTES

		The clouds separate behind Flanders,	revealing a full moon. Ned starts to twitch and contort,
	FLANDERS (SHEEPISH CHUCKLE) Yeah...	SIMPSONS/FLANDERS (LAUGH)	

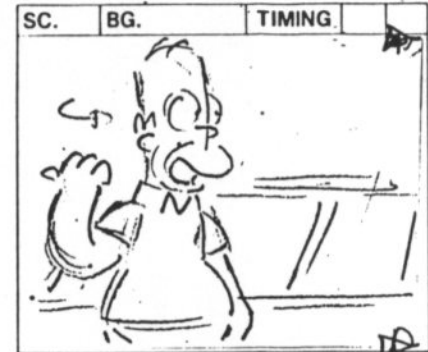
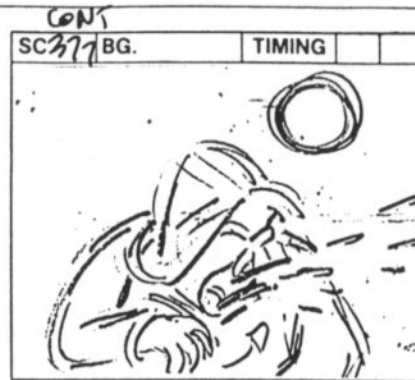
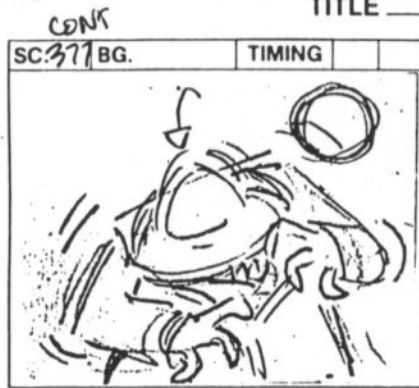

ACTION

making SHORT GROWLING SOUNDS

and FOAMING AT THE MOUTH.

Some of the foamy saliva lands on Homer.

Hook up set

*ADJUST OVER
MARGE + KIDS
GONE*

TRANS.

DIAL

HOMER
(WIPING SHIRT) Hey, Foamy, I want the news, not the weather.

(LAUGH) Marge, did you hear me zing Werewolf Flanders?

TRANS.

NOTES

379

SHOW

ACT

3

PAGE

216

CONT

TITLE

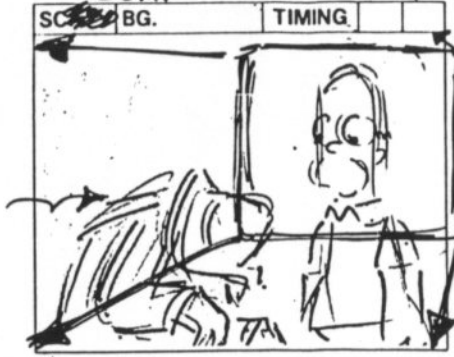
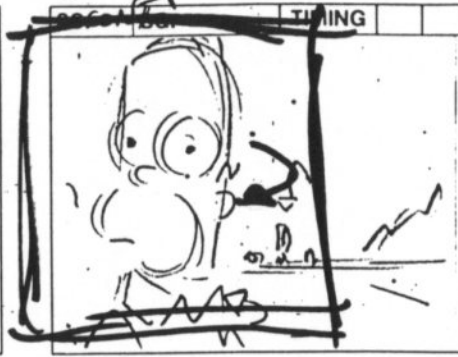
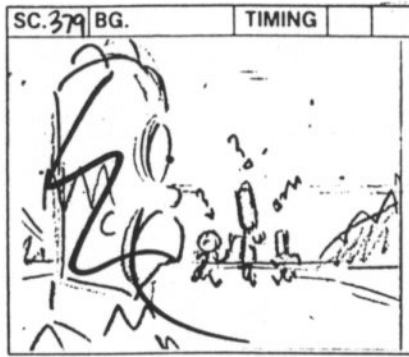
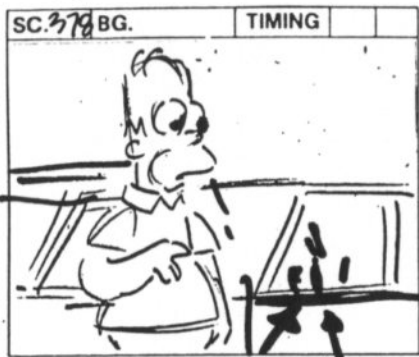

ACTION

Homer turns

to see the rest of the family in the distance, running at full speed.

He turns back

to see Ned

TRANS.

DIAL

TRANS.

NOTES

TITLE _____

SHOW _____

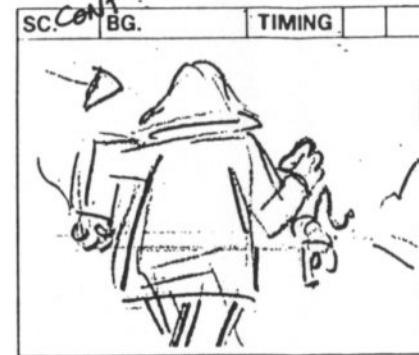
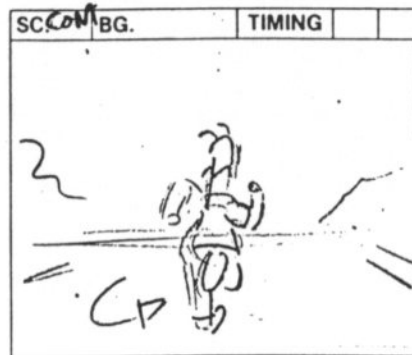
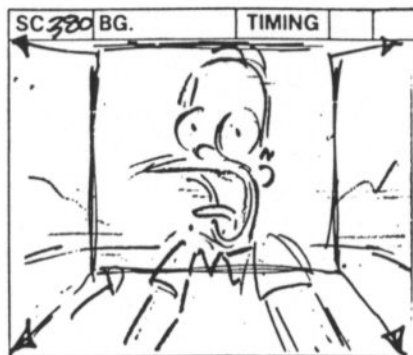

ACTION

has completed the transformation to werewolf.

Homer turns and runs as fast as he can.

Werewolf Ned powerwalks, feyly, after him, SNARLING VICIOUSLY.

TRANS.

DIAL

FLANDERS
(LOW MENACING GROWL WITH A "DIDDILY" IN THE MIDDLE)

HOMER
(FRIGHTENED SOUND)

TRANS.

NOTES

381

TITLE _____

SHOW BABFO1

ACT 3

PAGE 218

	SC. <u>381</u>	CONT	SC. <u>382</u>	SC. <u>383</u> BG.
	TIMING		TIMING	TIMING
ACT				
TRANS.	Homer quickly TIRES		and looks back to see Werewolf Ned is upon him.	
DIAL				
TRANS.				
NOTES				

TITLE

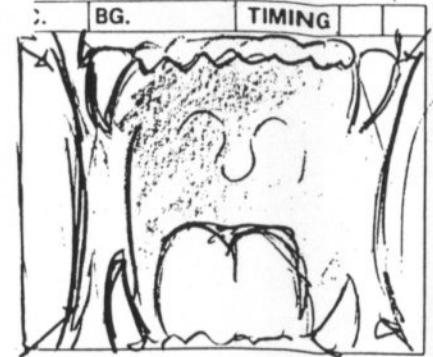
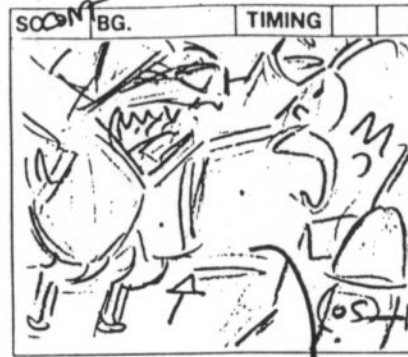

ACTION

Werewolf Ned LEAPS toward Homer.
As the camera PUSHES IN to the
blackness of the werewolf's throat,
we...

PUSH INTO BLACK

TRANS.

DIAL

TRANS.

NOTES

FLANDERS (V.O.)

(VORACIOUS FEASTING SOUNDS WHICH
QUICKLY PETER OUT TO "STUFFED" SOUND)

HOMER (V.O.)

Eyes bigger than your stomach, eh,
wolfie? (GLOATING CHUCKLE)

FLANDERS (V.O.)

(RESUMES SAVAGE FEASTING WITH RENEWED
VIGOR)